

Installation Instructions

Heat Recovery
Ventilator

VA3B/VB5B
VC5B

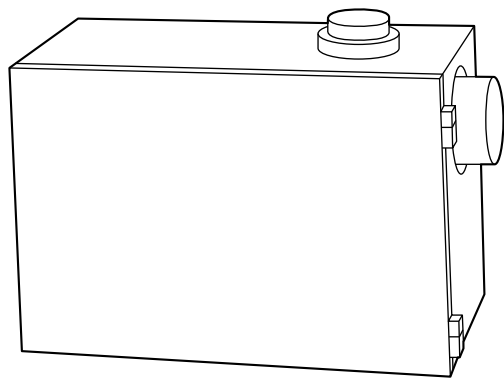

A92376

Fig. 1—VA3B Conventional Unit

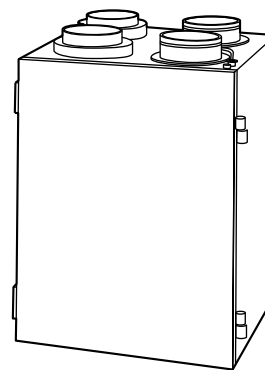

A92268

Fig. 2—VB5B Compact Unit

NOTE: Read the entire instruction manual before starting the installation.

SAFETY CONSIDERATIONS

Installing and servicing heating equipment can be hazardous due to gas and electrical components. Only trained and qualified personnel should install, repair, or service heating equipment.

Untrained personnel can perform basic maintenance functions such as cleaning and replacing air filters. All other operations must be performed by trained service personnel. When working on heating equipment, observe precautions in the literature, tags, and labels attached to or shipped with the unit and other safety precautions that may apply.

Follow all safety codes. In the United States, follow all safety codes including the National Fuel Gas Code NFPA No. 54-1988/ANSI Z223.1-1988. In Canada, refer to the current edition of the National Standard of Canada CAN/CGA-B149.1- and .2-M91 Natural Gas and Propane Gas Installation Codes. Wear safety glasses and work gloves. Have fire extinguisher available during start-up and adjustment procedures and service calls.

Recognize safety information. This is the safety-alert symbol . When you see this symbol on the furnace and in instructions or manuals, be alert to the potential for personal injury.

Understand the signal word DANGER, WARNING, or CAUTION. These words are used with the safety-alert symbol. DANGER identifies the most serious hazards which **will** result in severe personal injury or death. WARNING signifies a hazard which **could** result in personal injury or death. CAUTION is used to identify unsafe practices which **would** result in minor personal injury or product and property damage.

INTRODUCTION

The Heat Recovery Ventilator (HRV) is used to create an air exchange of stale indoor air with fresh outside air. Units are equipped with a heat recovery core which recovers heat that is contained in the stale air before it is exhausted, transferring it to the fresh air drawn from the exterior in winter.

Use this instruction to install Heat Recovery Ventilator (HRV) systems VA3B, VB5B, and VC5B. Units have varying capacity for air exchange as noted in product data. Confirm selected unit fits air quality requirements prior to installation. (See Fig. 1, Fig. 2, and Fig. 3.)

Move carton to final installation location. Remove HRV from carton taking care not to damage unit. Inspect unit for damage. File claim with shipping company if shipment is damaged or incomplete. Check to be sure unit matches job specifications. (See Fig. 4, Fig. 5, and Fig. 6.)

AIRFLOW DIAGRAMS

The direction of the airflow is indicated in Fig. 7 through Fig. 14. Stale air never mixes with fresh air. (See Fig. 7 through Fig. 14.)

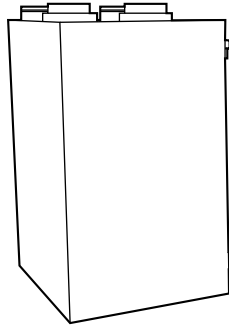

Fig. 3—VC5B High Efficiency Unit

A92377

PROCEDURE 1—FRESH AIR DISTRIBUTION

A. Forced-Air System

When the HRV is installed in conjunction with a new or existing forced-air system, the furnace blower and network of ducts are used to distribute the fresh air inside the building. To accomplish this, the furnace blower must operate continuously whenever the HRV is energized.

The fresh air from the HRV is introduced into the furnace return duct at a point no less than 6 ft (2 m) upstream of the furnace. This connection should be direct.

B. Independent System

In the absence of forced-air ductwork, the HRV requires an independent network of ducts for distribution of fresh air. Registers are normally located in the bedrooms, dining room, living room, and basement.

To ensure occupant comfort, it is recommended that register is placed 6 to 12 in. from the ceiling with airflow directed toward the ceiling. If registers are floor installed, airflow must be directed toward the wall.

PROCEDURE 2—SELECT LOCATION

The HRV should be located in close proximity to a drain and power source in a heated area of the house, such as the basement, and should be easily accessible for routine maintenance.

⚠ CAUTION: No stale air pickup registers may exist in the same room as a gas furnace or water heater.

PROCEDURE 3—MOUNT THE UNIT

The HRV unit must be level when installed. The HRV can be suspended from floor joists or rafters using chains and 4 springs. Attach metal hanging bracket to all 4 sides of cabinet. (See Fig. 19.)

If a rubber bumper is provided to dampen vibration, unit may be installed on a shelf. An area under the HRV must be provided to allow for drainage.

PROCEDURE 4—LOCATE STALE AIR INTAKE FOR SYSTEMS INDEPENDENTLY DUCTED

A. Location

Stale air is drawn from the kitchen, bathroom, basement, and from other rooms where contaminants are produced. Registers must be placed 6 to 12 in. from the ceiling and 6 ft from the oven if on an interior kitchen wall.

B. Airflow

Proper type and size of registers must be used to minimize decreases in pressure. The velocity of the air flowing through the register should not be above 400 ft/minute (2 m/sec).

C. Maximum Length of Duct

The ducting system should be designed according to the highest speed of the unit. Refer to the specifications listed in the product data sheets for the ventilation capacities.

PROCEDURE 5—CONNECT DUCTS AND CONDENSATE DRAIN TO THE HRV

A. Ducts

Insulated flexible ducts are required on both the fresh air inlet and the exhaust air outlet ducts connecting to the exterior of the house. These ports are identified by their double flange collars. If using insulated flexible duct, the vapor barrier of the flexible ducts must be taped very tightly.

The 36-in. section of flexible duct supplied with the unit should be cut in half and connected to both the stale air port and the fresh air distribution port. This will eliminate the transmission of vibrations from the unit to the main ducts. (See Fig. 20.)

Four 30-in. duct ties are provided to fasten flexible duct to ports of the HRV.

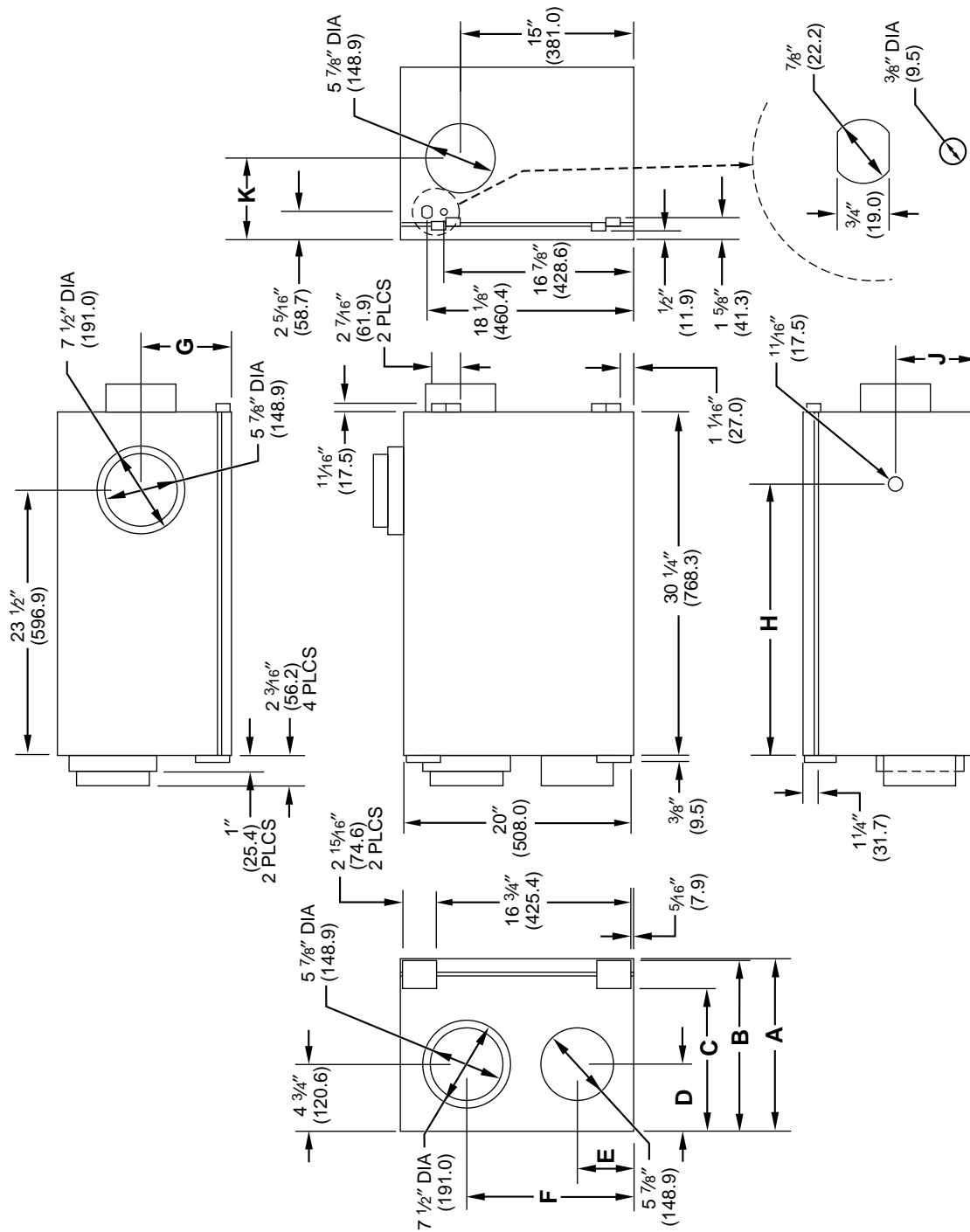

A92274

MODEL NO.	A		B		C		D		E		F		G		H		J		K	
	In.	mm	In.	mm	In.	mm	In.	mm	In.	mm	In.	mm	In.	mm	In.	mm	In.	mm	In.	mm
VA3BAB015	15-3/16	385.8	14-3/4	374.6	12-7/8	327.0	4-3/4	120.6	5-1/8	130.2	14-3/4	374.6	7-5/8	193.6	20-3/8	517.5	7-5/16	185.7	7-3/4	196.8
VA3BAB020	18-7/8	479.4	18-5/8	473.1	16-5/16	414.3	13-1/2	342.9	5-7/8	149.2	14	355.6	10	254.0	15-13/16	401.6	9-5/16	236.6	8-13/16	223.8

Fig. 4—Dimensional Drawing VA3B

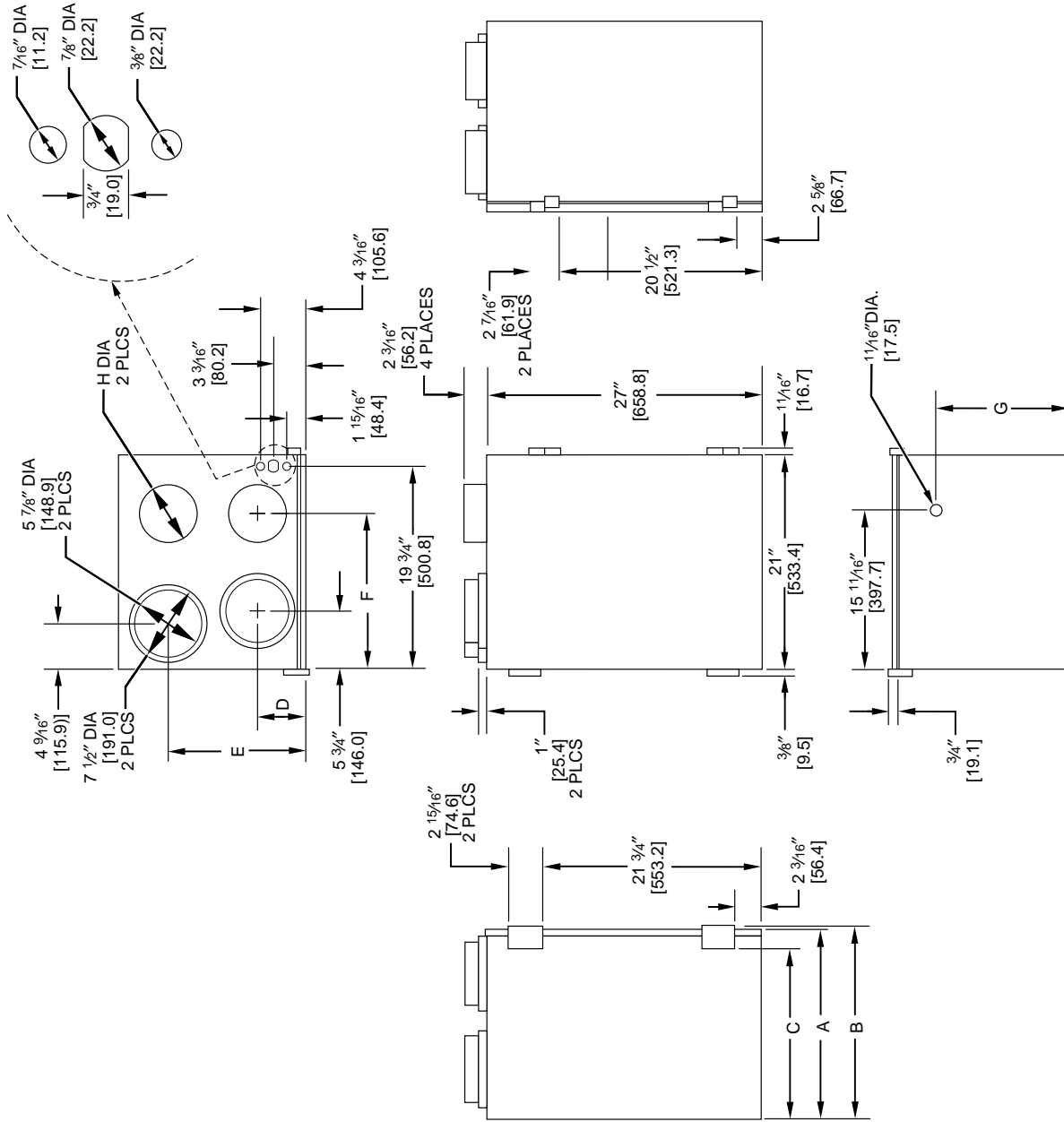

A92275

MODEL NO.	A		B		C		D		E		F		G		H	
	In.	mm	In.	mm	In.	mm	In.	mm	In.	mm	In.	mm	In.	mm	In.	mm
VB5BAB015	18-3/8	466.7	18-3/8	466.7	16-9/16	420.7	4-11/16	119.1	13-5/16	388.2	15-7/16	392.1	13-9/16	344.5	5-11/16	144.5
VB5BAB020	24-1/4	615.9	24-1/2	622.2	22-3/16	563.5	8-3/16	208.0	19-5/16	490.6	14-9/16	369.2	16-15/16	429.4	6-15/16	176.2
VC5BAB015																

Fig. 5—Dimensional Drawing VB5B, VC5BAB015

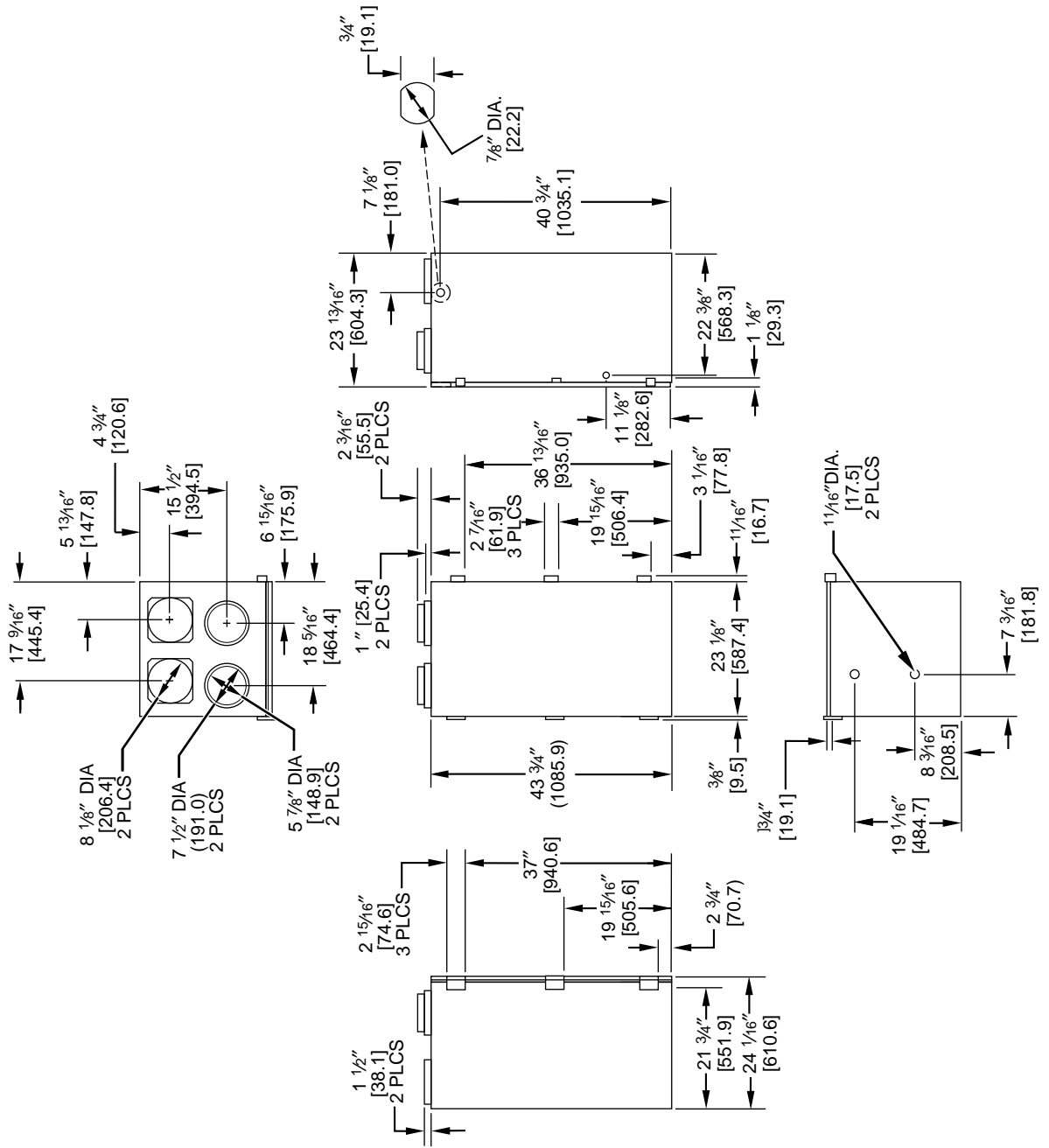

Fig. 6—Dimensional Drawing VC5BB020, B027

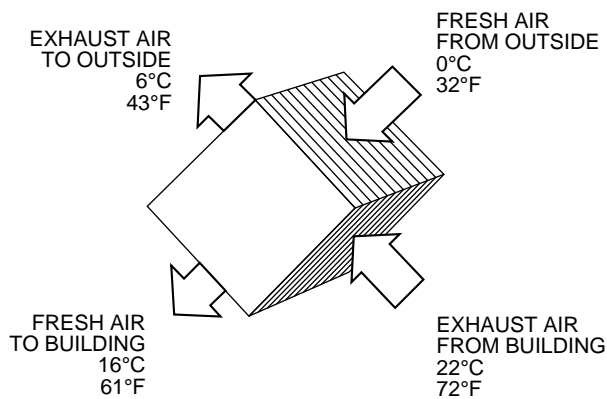

Fig. 7—VA3B/VB5B Cross-Flow

A92378

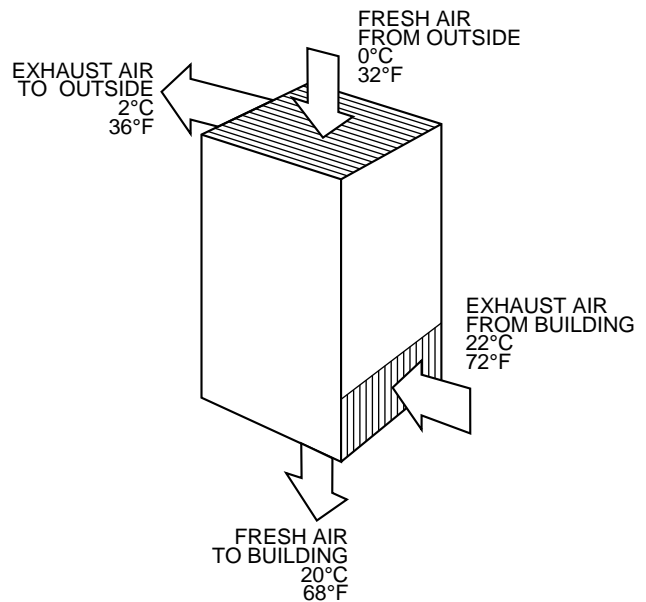

Fig. 8—VC5B Counter Flow

A92379

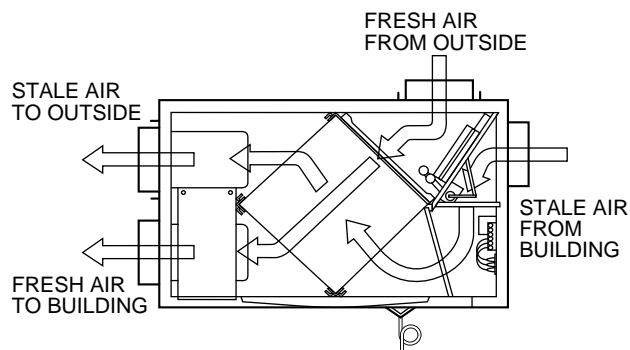

Fig. 9—VA3B Airflow During Air Exchange

A92380

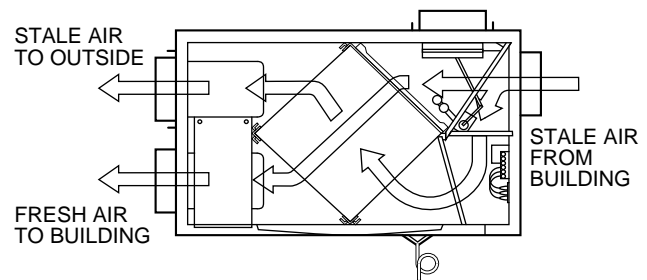

Fig. 10—VA3B Airflow During Defrost

A92381

B. Condensate Drain

To connect condensate drain, insert sleeved grommets into bottom of unit. Insert drain tube over sleeved grommets and assemble tubing to the "T" connector. (See Fig. 21.) Glue the drain tubing and grommet together with contact cement. Use a wire tie to fasten the vinyl tubing onto the sleeved grommets, if necessary.

Make a loop in the tubing below the "T" connector to create a trap to prevent sewer gases from entering the ventilation system. (See Fig. 21.) Connect the unit's drain to the building's main drain. Provide slight slope for run-off.

PROCEDURE 6—COMPONENT DESCRIPTION

The following lists components of HRV units VA3B, VB5B, and VC5B. (See Fig. 15 through 18.)

1. Stale air port is connected to the return-air supply.
2. Fresh air port connects to outdoor air-inlet hood.
3. Exhaust port connects to outdoor exhaust hood.
4. Dampers are used to control air exchange with outside air and used during defrost mode.
5. Mechanical filter traps dust contained in the air.
6. Heat recovery core is either a cross-flow type for compact models or a counter-flow type for high-efficiency models. It transfers the heat between the 2 airstreams.
7. Blowers bring in fresh air from the outside and exhaust stale air to the outside.
8. Capacitor required for motor operations.
9. Condensation tray collects condensate from heat recovery core.
10. Drainage tube connects to sleeved grommets.
11. Electronic control circuit ensures proper operation of unit.

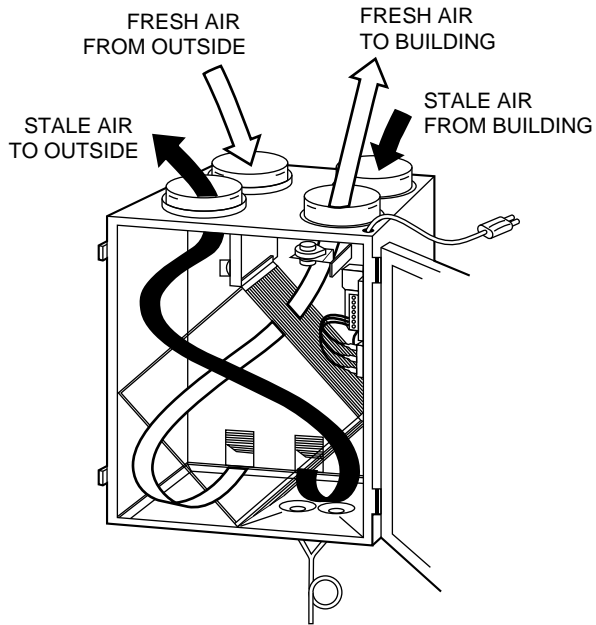

Fig. 11—VB5B Airflow During Air Exchange

A92382

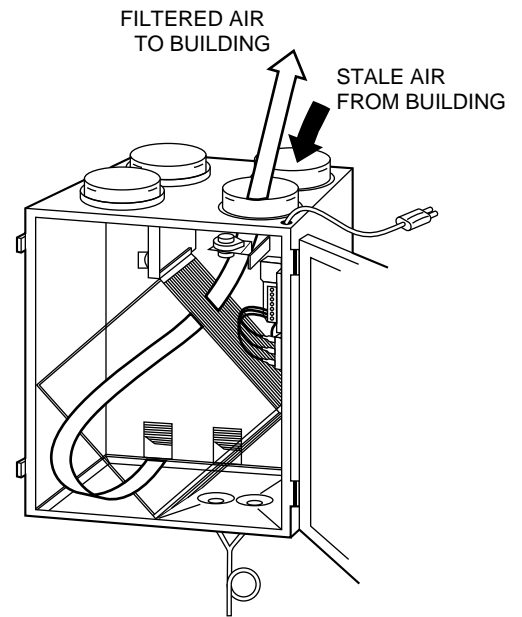

Fig. 12—VB5B Airflow During Circulation and Defrost

A92383

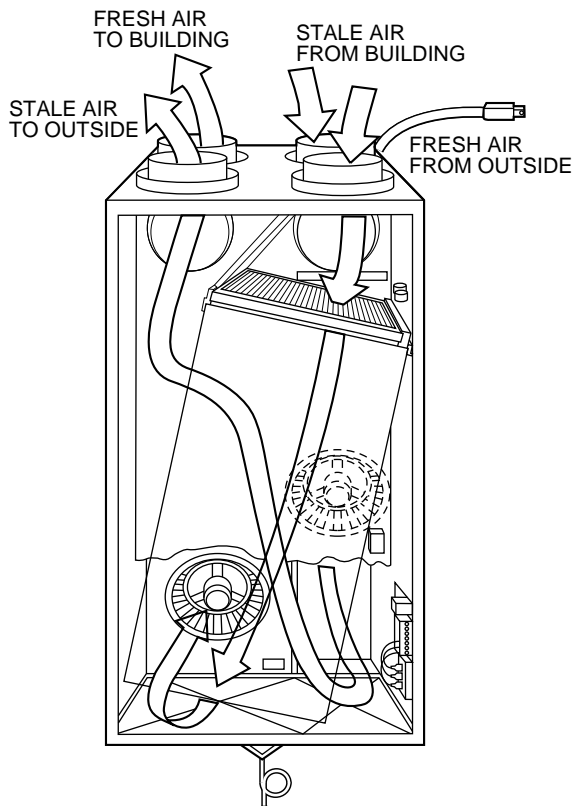

Fig. 13—VC5B Airflow During Air Exchange

A92384

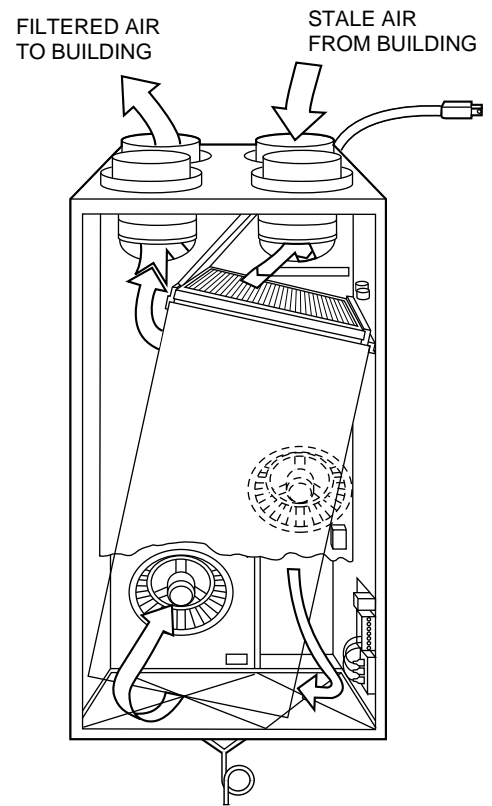

Fig. 14—VC5B Airflow During Circulation and Defrost

A92385

- 12. Ionizer is available with automatic wall control and is used to neutralize fine dust particles. It is not used with a forced- air system.
- 13. Distribution port distributes fresh air into the house.
- 14. Control connector allows connections with control wiring.
- 15. Electrical cord connects to standard 120v outlet.

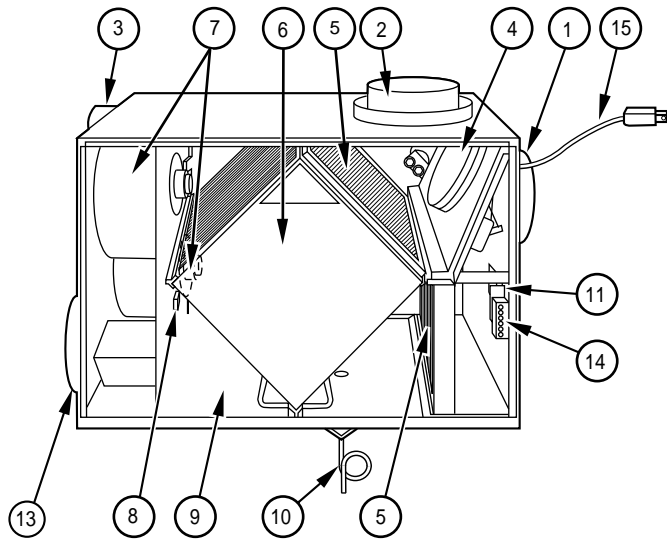

Fig. 15—VA3B Conventional Unit with 2 PSC Motors

A92387

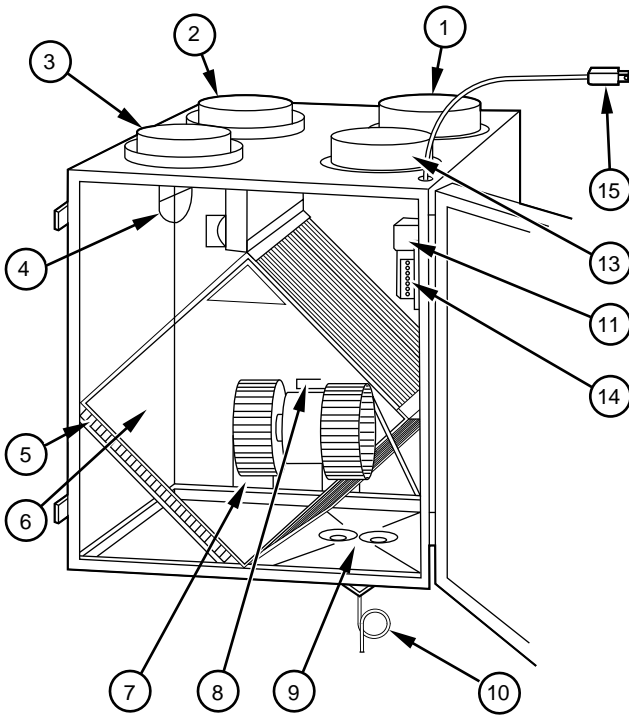

Fig. 17—VB5B Compact Unit

A92389

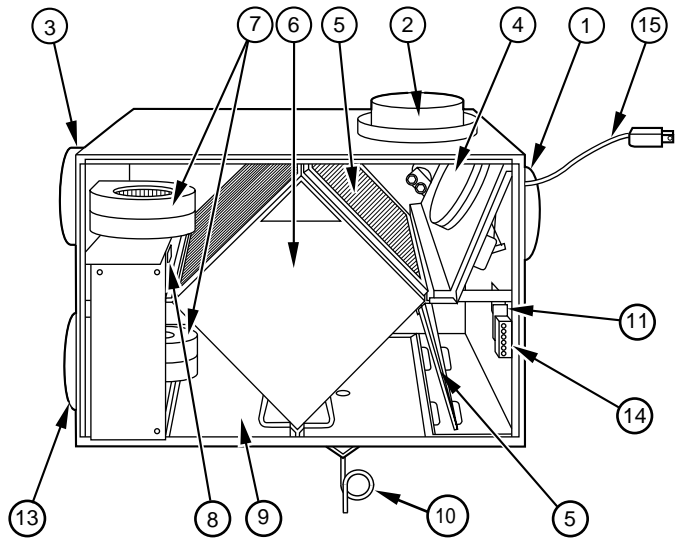

Fig. 16—VA3B Conventional Unit with 1 PSC Motor

A92388

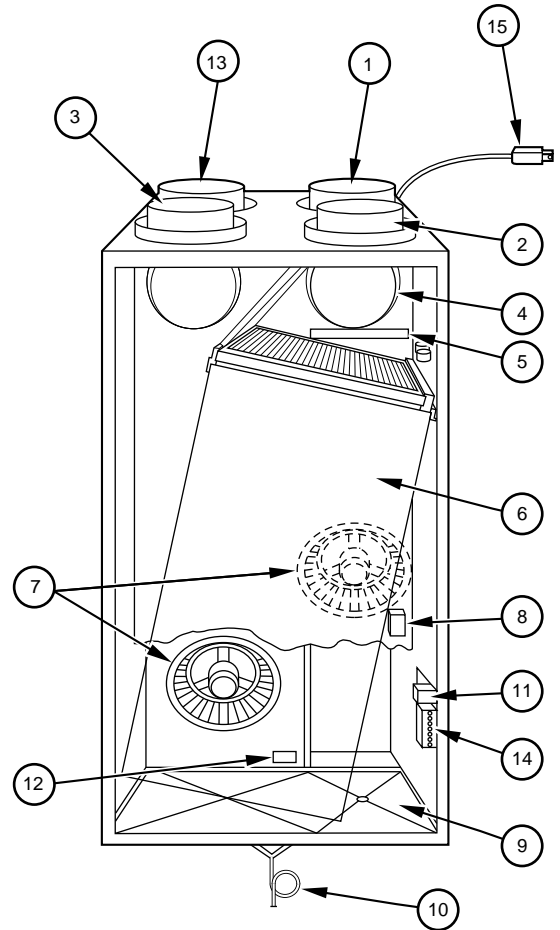

Fig. 18—VC5B Compact High-Efficiency Unit

A92390

PROCEDURE 7—LOCATE AND INSTALL EXTERIOR HOODS

A. Location

Separate the fresh air intake and stale air exhaust 6 ft (2 m). Position fresh air intake at least 10 ft (3 m) from the nearest dryer vent, furnace exhaust, driveway, gas meter, or oil fill pipe, and as far as possible from garbage containers and potential chemical fumes. When possible, it is advised to locate the intake and exhaust on opposite walls of the building or around a corner from each other. Never locate exhaust and supply hoods on interior corners or in dead air pockets. (See Fig. 22.) Both intake and exhaust hoods must be 18 in. from the ground and at least 12 in. above the anticipated snow level.

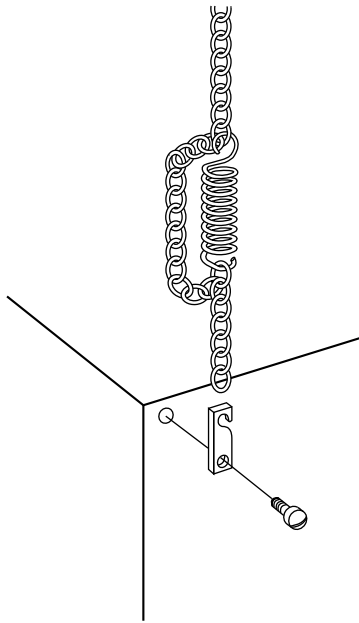

Fig. 19—Chain Spring Installation

A92269

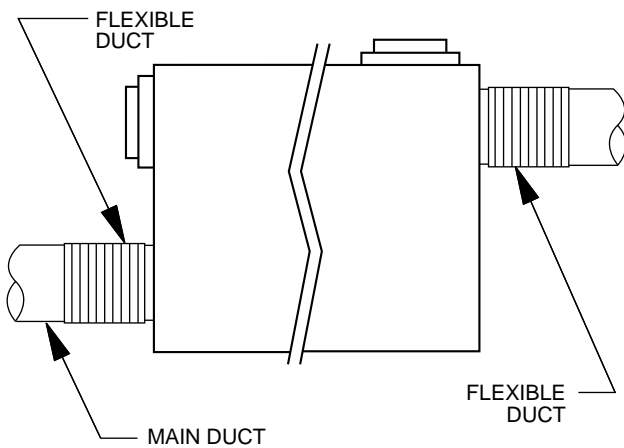

Fig. 20—Flexible Duct Fit-up

A92270

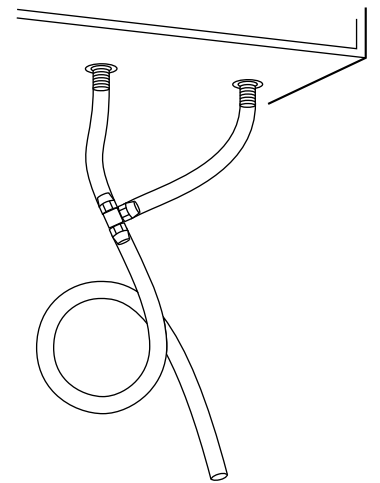

Fig. 21—Loop Trap

A92392

Both the intake and exhaust hoods must be supplied with a rodent screen. Wire mesh of 1/4 in. (6mm) is recommended. Smaller mesh screens must be easily removed for cleaning. The free area of the exterior hoods must be equivalent to the connecting diameter of the HRV.

B. Installation

Insulated flexible duct is required for both inlet and outlet outside connections to the HRV. After making the appropriate sized wall penetration, pass the flexible duct through the opening and insert the hood tube into the duct. Tape the duct vapor barrier tightly around the hood tube and insert the assembly back into the hole in the wall and fasten securely.

PROCEDURE 8—INSTALL WALL CONTROLS

NOTE: When using a forced-air system in conjunction with an HRV, a slave relay must be used to ensure a continuous blower-interlocked operation.

A. Location

Install the wall control on ground floor of building. Locate as close as possible to the main thermostat, or within the flow of circulated fresh air. Position wall control approximately 60 in. (1.5 m) above floor.

B. Wall Control and Wiring

Connect wire to the wall control following the color code. Attach wall control to wall. (See Fig. 23.) Following the color code, connect wire to the unit by passing it through the hole located on top or right side of unit. (See Fig. 24.)

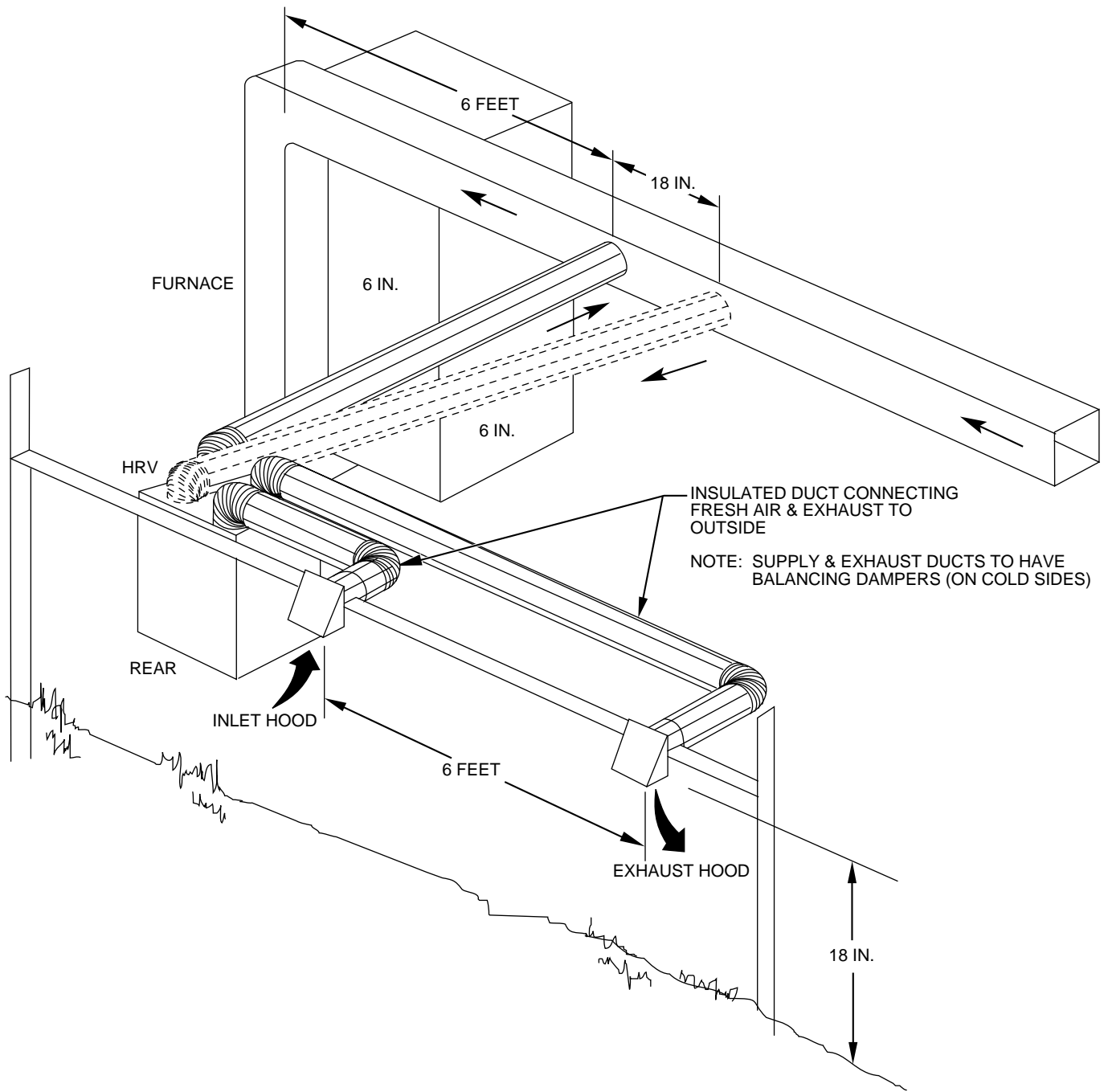

Fig. 22—Exhaust Ventilation

A92396

Determine type of control to be used - basic, standard, or auto. The standard and auto models function similarly and consist of a knob, mode switches, and LED mode indicators.

BASIC CONTROL

This control includes a 3 position slide switch to select off, low, or high fan speeds. (See Table 1.)

STANDARD CONTROL

There are 2 operating modes available. (See Table 2.) The slide switch allows selection of the following:

1. With the switch off the HRV is inoperative and both LEDs are extinguished.
2. The low exchange mode continually exchanges air with the outside. If the dehumidistat is satisfied the air exchange is on low speed, Otherwise the unit is on high speed. Both LEDs are illuminated at all times.
3. The intermittent mode exchanges air with the outside at high speed and shuts down the unit when the dehumidistat is satisfied. The on LED is illuminated at all times and the exchange LED is illuminated while the unit is running. This mode is ideal for maintaining the proper humidity level when no one is home.

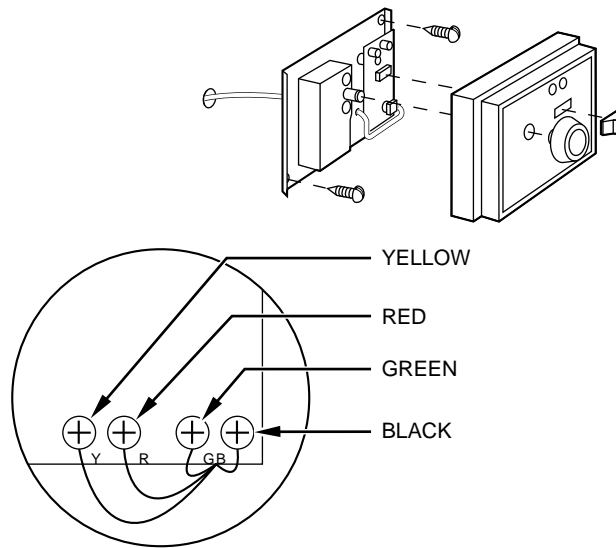

Fig. 23—Typical Wall Control

A92272

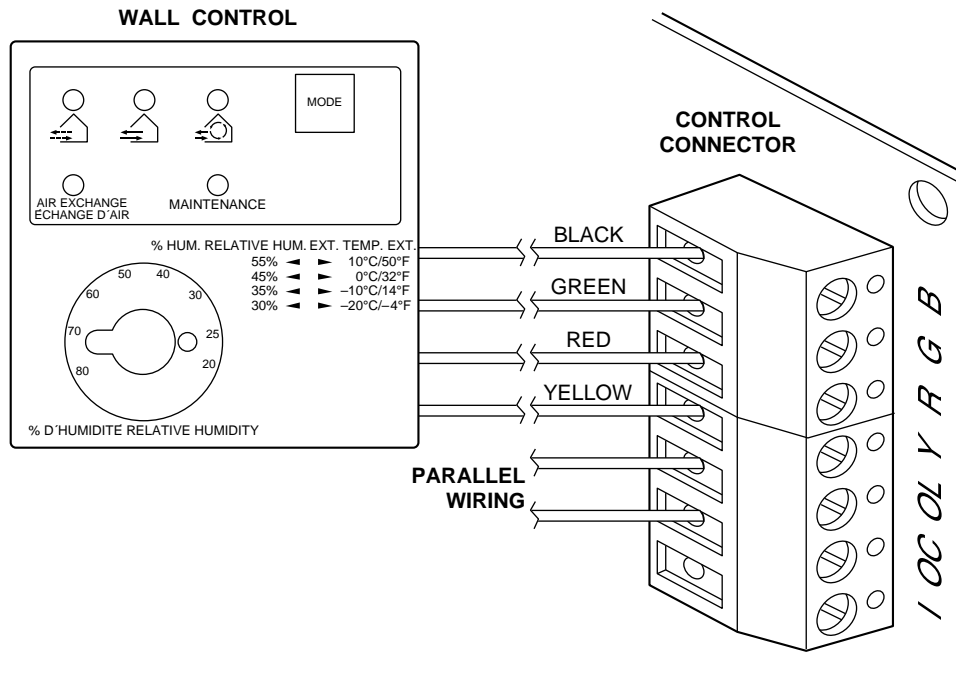

Fig. 24—Control Connector

A92397

AUTOMATIC CONTROL

There are 3 operating modes available using a push button switch which cycles between modes. (See Table 3.)

NOTE: This control is designed to be used only with installations which are independent of the HVAC system.

1. Initially the switch is off. All LEDs are extinguished and the HRV is inoperative.
2. The first push of the button puts the HRV into intermittent mode. The HRV operates at high speed when there is a call for dehumidification. The intermittent and exchange LEDs are both illuminated. When the dehumidistat is satisfied, the HRV shuts down and the exchange LED light goes out.
3. The next push of the button puts the system into continuous mode. The continuous and exchange LED lights remain on. The HRV runs on high speed during calls for dehumidification and low speed when dehumidistat is satisfied.

4. The next push of the button places the system in circulation mode and the HRV operates on high speed at all times. The circulation LED remains on. When there is a call for dehumidification, the exchange LED is on and the HRV exchanges air with the outside. When the dehumidistat is satisfied the HRV dampers close, recirculating indoor air. The exchange LED goes off.
5. The maintenance light illuminates every 3 months to indicate that the filter should be cleaned. It is reset by opening the door to the HRV.

PROCEDURE 9—CHECK CONTROLS' OPERATING MODES

Be sure that all modes of operation are fully functional. Table 1 through 3 indicate the available modes of operation with the various wall controls. The HRV is supplied with a 3-speed blower as shipped. The high blower speed corresponds to the #1 speed tap and the low speed corresponds to the #3 tap. If more air delivery is desired on low speed, remove the insulator from the #2 (blue) wire from the motor and connect the red lead from the unit control board to this terminal. Place the insulator over the connector on the #3 (red) wire to the motor.

PROCEDURE 10—HUMIDITY SELECTOR

The Humidity Selector is a built-in dehumidistat designed to properly control the level of humidity in the house during the winter months. This control helps avoid condensation problems in upper northern regions where indoor humidity is a problem during the winter season.

NOTE: This control is not to be confused with a dehumidistat used during the summer months to control high relative indoor humidity.

Table 4 recommends humidity levels to avoid condensation.

PROCEDURE 11—MISCELLANEOUS CONTROLS

A. Defrost—Not User Adjustable

At 23°F (-5°C) the unit will initiate a defrost cycle by closing the outside air damper and recirculating heated indoor air through heat recovery core. This happens approximately every hour with a 5 minute defrost cycle. In this fashion, the core is defrosted without the use of electric strip heat. At 5°F (-15°C) the unit will defrost for 5 minutes every half hour. At -22°F (-30°C) the unit will sense a need for defrost every 20 minutes with a 5 minute cycle.

B. Push Button Timer

A push button (20-minute) can be used to override wall control. The P/N KVBTM010120M includes 3 push button switches.

Connect the leads to HRV terminals I, OC, and OL on control connector. (See Fig. 25.) Connect push button switches in parallel. For kit KVARM010160M connect power supply to 120-v junction box.

Also available is a 60-minute variable timer kit KVATM010160M which in conjunction with the internal timer provides up to 80 minutes of operation.

C. Interlock Relay

The HRV is independently controlled. An interlock relay must be added when combining the HRV with a forced-air furnace or fan coil. When the HRV is energized, the interlock relay is also energized, energizing both R and G terminals inside the furnace or fan coil. This allows continuous blower operation circulating both fresh air and return air throughout the ducted system. (See Fig. 26.)

NOTE: If the HRV is wired to operate in response to furnace airflow using kit KVAAC0101PSI for example, then low voltage terminals are not used.

PROCEDURE 12—BALANCING

The arrow on the flow collar is always oriented with the airflow.

TEMPORARY FLOW COLLARS

NOTE: Flexible connectors should be located suitably to measure airflow. Always try to locate flow measuring collars in the straightest sections of duct to ensure accuracy. (See Fig. 27 or Fig. 28.) If only 1 flow collar is available, the flow collar is mounted in stale air duct of the HRV, and the airflow recorded. The flow collar is then relocated to the fresh-air duct, and airflow is recorded again. Dampers can then be adjusted to equalize airflow. The procedure should be repeated to ensure the unit is balanced properly.

Balancing is very important for proper operation of a HRV. If supply air from outside is greater than exhaust air from the house, the imbalance can result in the core of the HRV freezing up. If exhaust air from the house is greater than the supply air from the outside, combustion appliances may backdraft, bringing exhaust fumes into the house. A balanced condition will ensure optimum performance, provide satisfied customers, and avoid expensive callbacks. Installation of the balancing dampers in insulated ducts is strongly recommended.

1. Before proceeding with balancing, all windows, doors, and fireplace flues should be tightly closed. No exhaust systems, such as range top exhausts, dryer exhaust, fume hoods, bath, or roof fans, should be in operation. The forced-air furnace, if used for circulation, should be operating at its continuous operating speed. Fully open balancing dampers.
2. With the speed control at maximum speed and continuous air exchange with the outside occurring, connect the hoses from the flow collar to a magnehelic gage. (See Fig. 29.) The gage must be leveled and zeroed before use to read accurately. If the needle falls below zero, reverse the hose connections.
3. Measure the exhaust air first as it is often the lowest pressure due to a longer ductwork system. Next, measure the fresh air. If the fresh air reading is higher than the exhaust reading, adjust the damper until the reading is the same. If the reading is lower, return the grid to the exhaust damper to obtain the same reading.

⚠ CAUTION: Do not use HRV during the construction of a house or when sanding drywall. This type of dust may damage the system.

PROCEDURE 13—VENTILATION EVALUATION

Two methods used to evaluate the ventilation needs of a house are:

1. The total number of rooms x 10 cfm (5 l/s) per room, plus 20 cfm (10 l/s) for a master bedroom or basement.

Table 1—Basic Controls

MODE	TYPE OF OPERATION	FAN SPEED
Off	Off (Dampers close-off to outside)	Off
Low	Air Exchange With Outside	Low
High	Air Exchange With Outside	High

Table 2—Standard Controls

MODE	DEHUMIDISTAT POSITION	TYPE OF OPERATION	FAN SPEED	INDICATOR LED'S
Off	Any	Off(Dampers Closed to Outside)	Off	OFF
Low	Satisfied	Air exchange with outside	Low	Both ON
	Call for dehumidification		High	
Intermittent	Satisfied	Off(Dampers Closed to Outside)	Off	ON light on Exchange OFF
	Call for dehumidification	Air Exchange with Outside	High	Both ON

Table 3—Automatic Controls

MODE	DEHUMIDISTAT POSITION	TYPE OF OPERATION	FAN SPEED	INDICATOR LED'S
Off	Any	Off (dampers closed to outside)	Off	All Off
Intermittent	Satisfied	Off (dampers closed to outside)	Off	Intermittent ON
	Call for Dehumidification	Air Exchange with Outside	High	Intermittent and Exchange ON
Continuous	Satisfied	Air Exchange with Outside	Low	Continuous and Exchange ON
	Call for Dehumidification	Air Exchange with Outside	High	Continuous and Exchange ON
Circulation	Satisfied	Recirculation (dampers closed to outside)	High	Circulation ON
	Call for Dehumidification	Air Exchange with Outside	High	Circulation and Exchange ON
Any	Any	Any	Any	Maintenance (open door)

Table 4—Recommended Humidity Levels

OUTSIDE TEMPERATURE		DOUBLE-PANE WINDOWS	TRIPLE-PANE WINDOWS
50° F	10° C	55 percent	65 percent
32° F	0° C	45 percent	55 percent
14° F	-10° C	35 percent	45 percent
-4° F	-20° C	30 percent	45 percent
-22° F	-30° C	25 percent	35 percent

If the level of humidity falls too low in the winter months while operating in the continuous exchange mode, a humidifier may be integrated into the system. Intermittent exchange mode may also be selected for short periods of time to increase the level of humidity.

- Air exchange at 0.3 per hr x the volume of the house.

The ventilation capacity of the HRV unit while at maximum speed is defined according to the greatest total. These methods are derived from the National Building Code 1990 version and the CSA F326.1 revision.

In the illustration, there are 11 noted rooms, a master bedroom and a basement. (See Fig. 30.) Using method 1 to calculate approximate ventilation:

- $(11 \times 10 \text{ cfm}) + (2 \times 20 \text{ cfm}) = 150 \text{ cfm}$

Referring to the same illustration and using method 2 to calculate approximate ventilation:

- $1,320 \text{ sq ft} \times 8 \text{ ft in height} = 10,560 \text{ cu ft per floor}$
- $10,560 \text{ cu ft} \times 3 \text{ floors} = 31,680 \text{ cu ft in house}$
- $31,680 \text{ cu ft} \times 0.3 \text{ air change per hour} = 9,500 \text{ cu ft per hour}$
- $9,500 \text{ cu ft} \div 60 \text{ min per hour} = 160 \text{ cfm}$

The greatest total is 160 cfm, a capacity within the range of a VC5BB020 size unit.

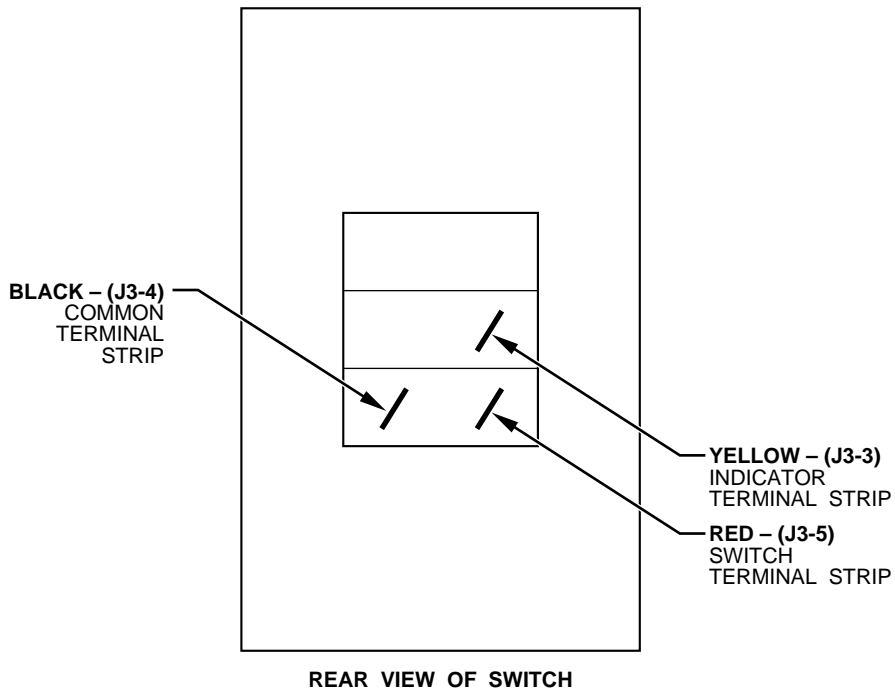
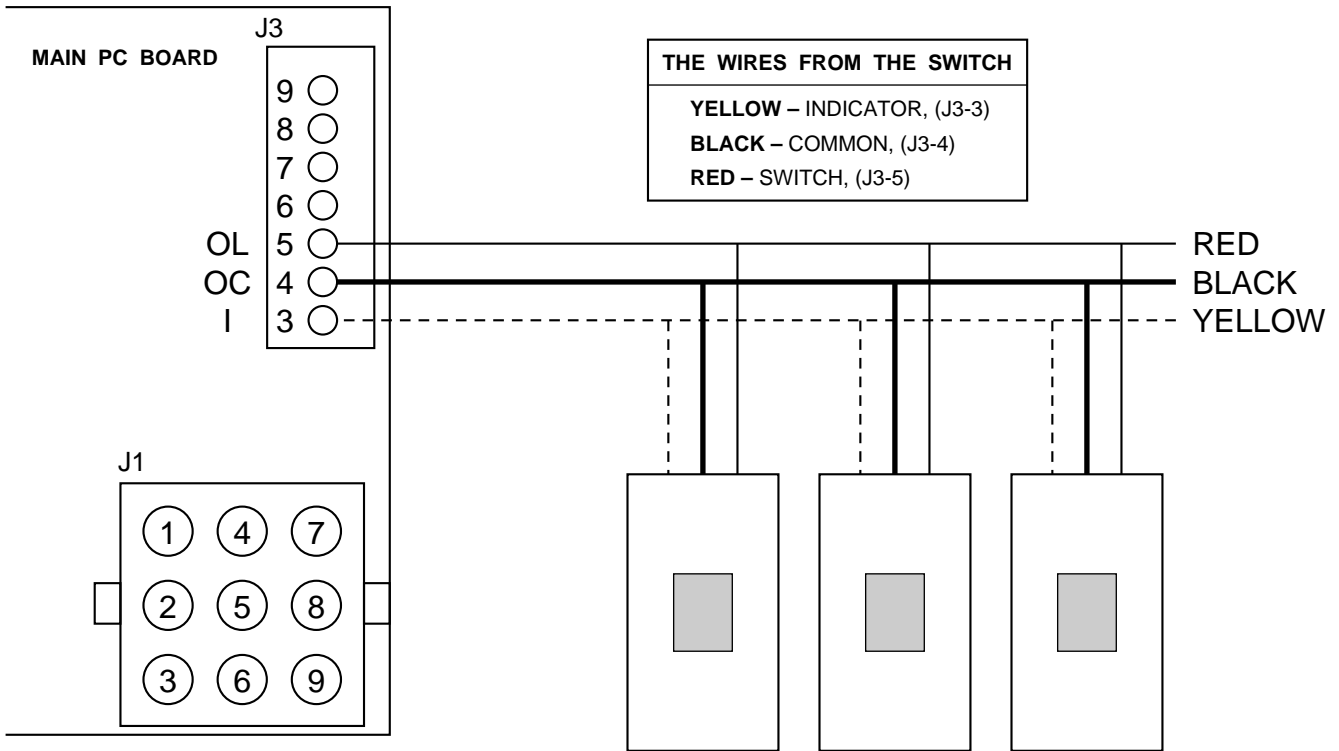

Fig. 25—Push Button Timer Wiring Layout

A92399

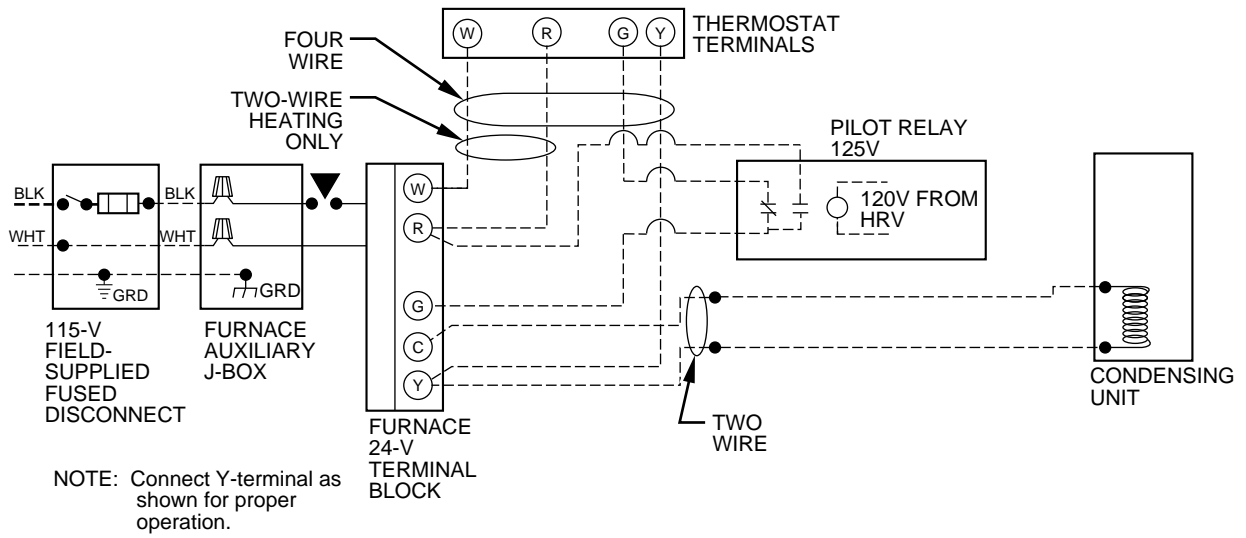

Fig. 26—Interlock Relay Wiring Layout

A92402

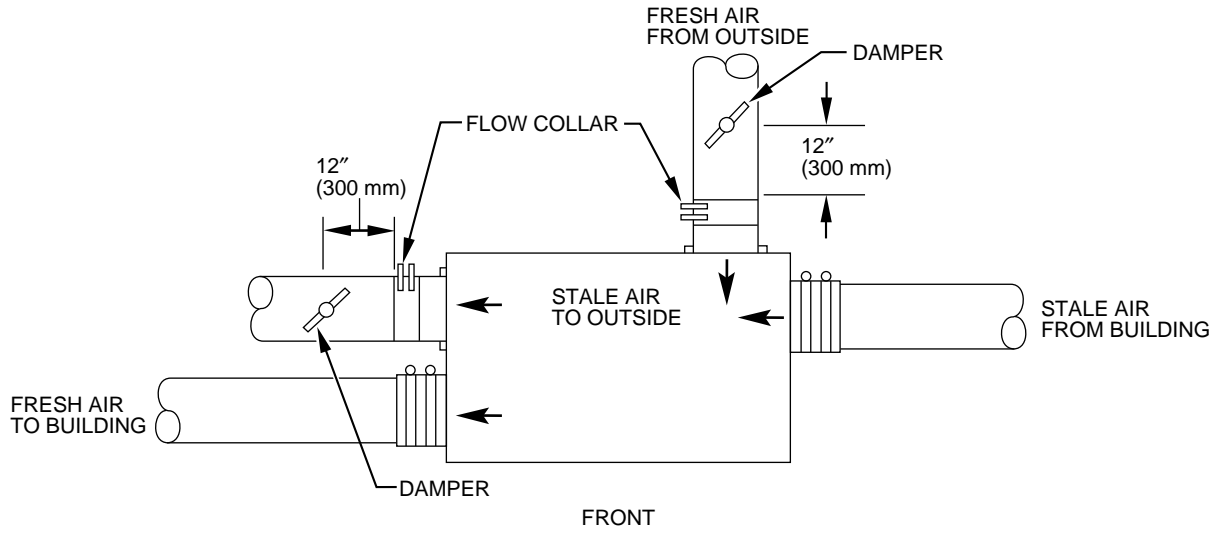

Fig. 27—Balancing VA3B

A92403

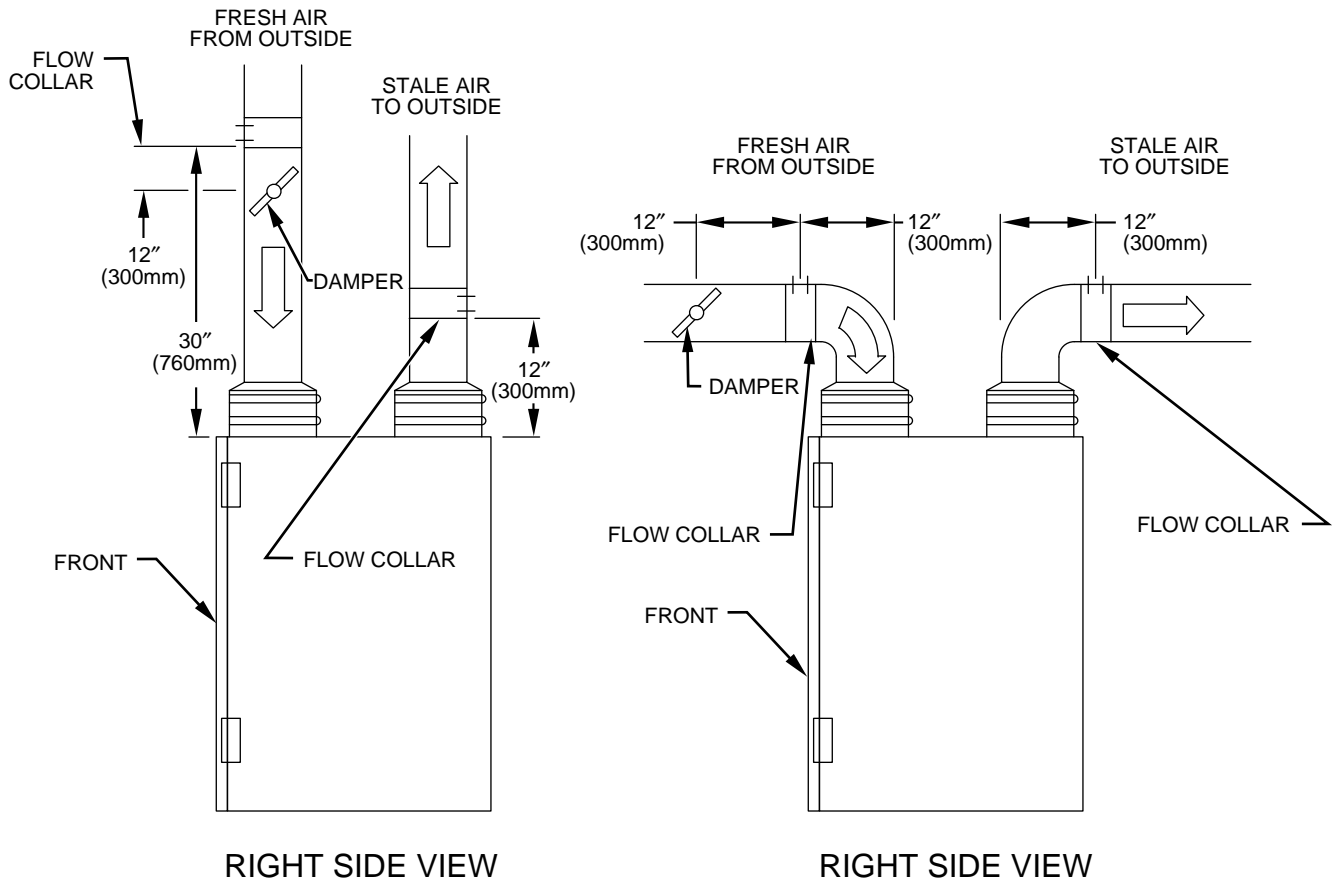

Fig. 28—Balancing VB5B and VC5B

A92404

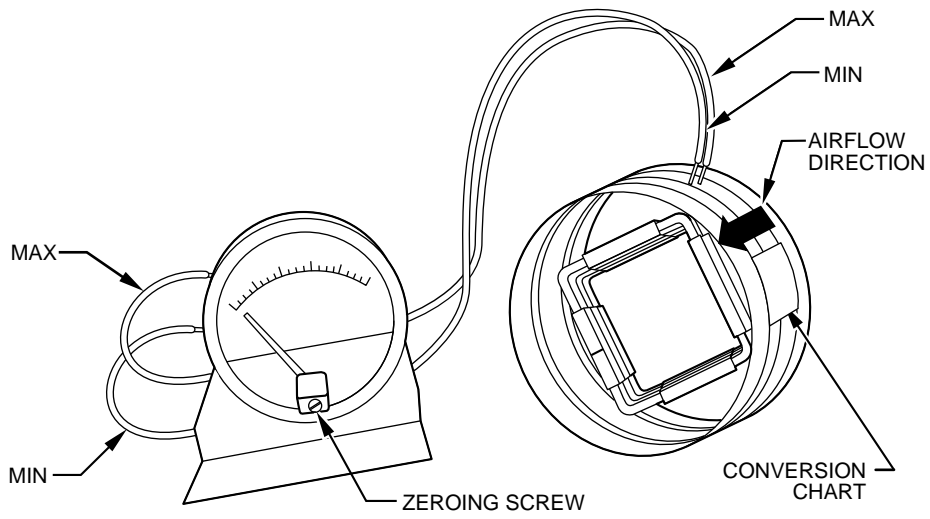

Fig. 29—Magnehelic Gage

A92273

Table 5—Troubleshooting the HRV

SYMPTOMS	CAUSES	SOLUTIONS
Air too dry	Continuous exchange mode used in small houses	Check humidity level settings
Persistent condensation on windows	Improper adjustment of control	Adjust humidity level
	Improper ventilation rate	Install a dehumidstat
Unit stops momentarily	Electrical supply interrupted	Check units circuit breaker
Wall control not operating	Broken control wire	Test wire control and wall control
Air from distribution register too cold	Improper calibration of air flow	Check calibration of flow rates
	Outdoor temperature extremely cold	Install electric duct heater if necessary
Unit makes annoying noise	Ventilation wheel out of adjustment	Remove the motor and screw the wheel on properly
Noise level too high at distribution registers when in high speed	Air duct system too short	Install a silencer

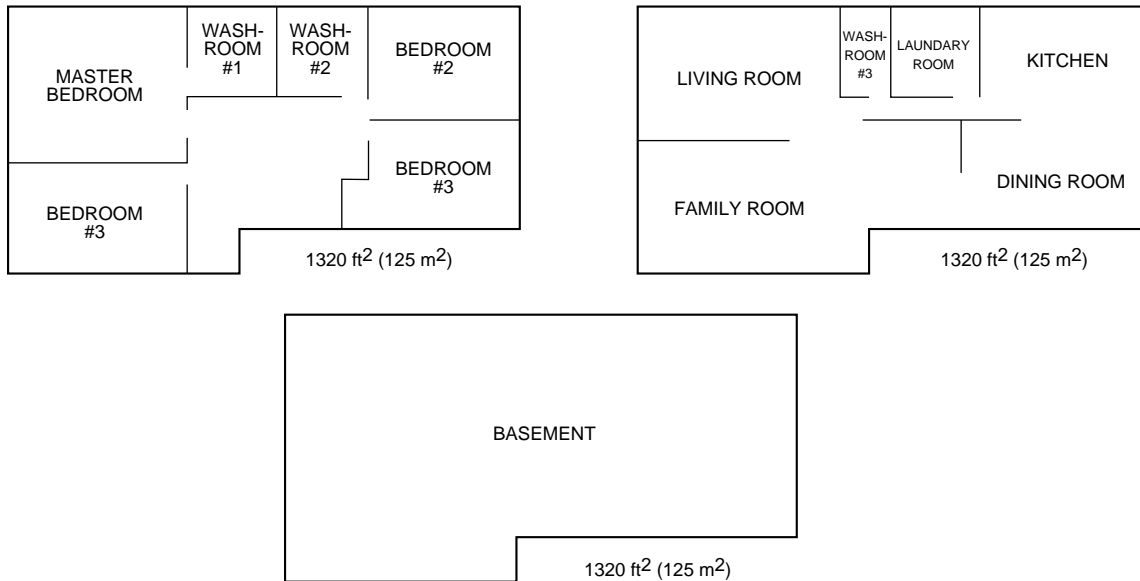
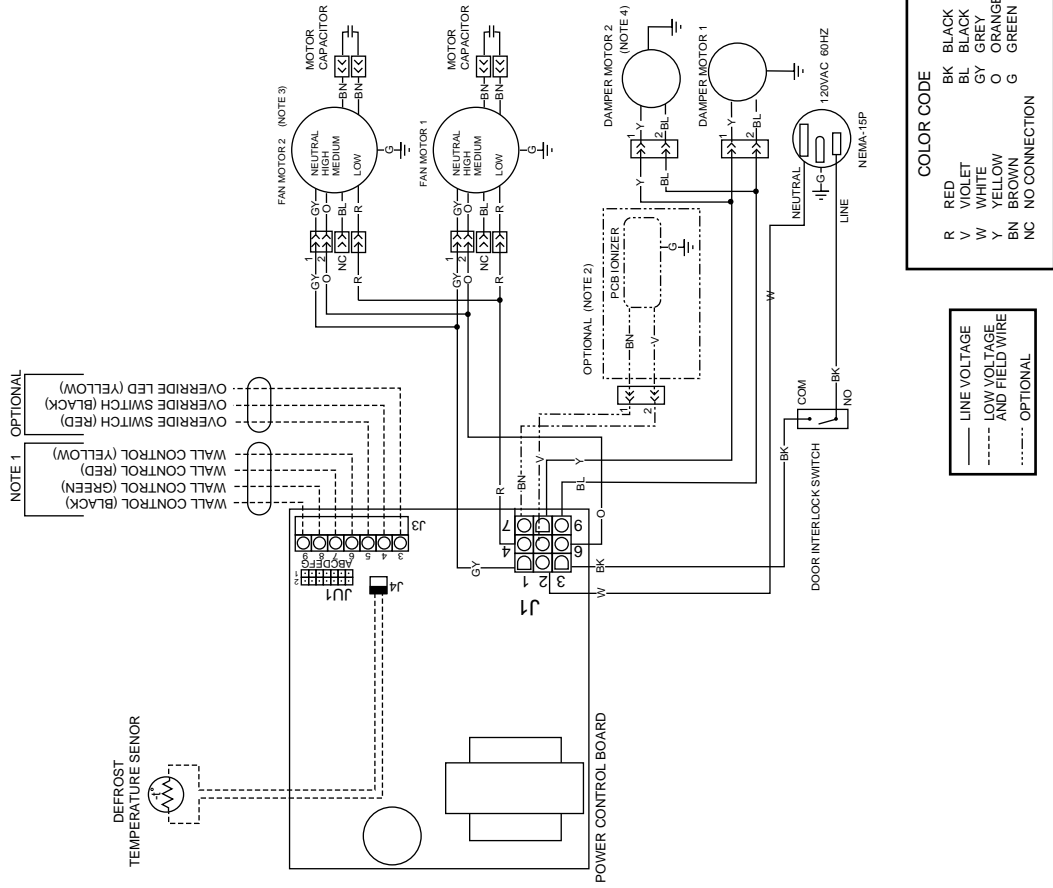

Fig. 30—Floor Plan Example

A92421

CONNECTION DIAGRAM



COLOR CODE

R	RED
V	VIOLET
W	WHITE
Y	YELLOW
BN	BROWN
NC	NO CONNECTION
BK	BLACK
BL	BLACK
GY	GREY
O	ORANGE
G	GREEN

LINE VOLTAGE AND FIELD WIRE

— LINE VOLTAGE

- - - LOW VOLTAGE

..... OPTIONAL

LOGIC DIAGRAM

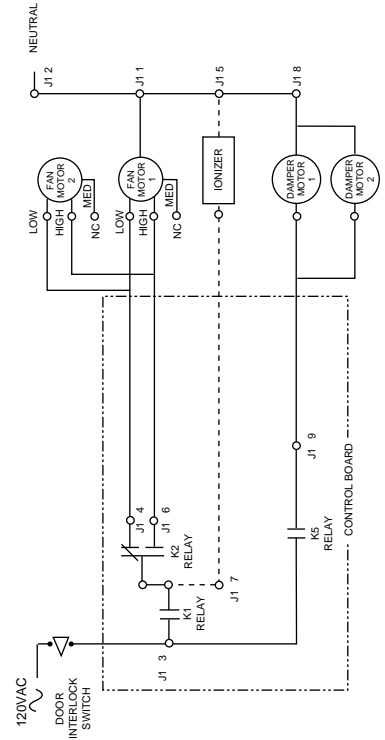

FUNCTION TABLE A		JUMPER TABLE					MODEL	FUNCTION TABLE LETTER									
MODE	RELAY	JU1A	JU1B	JU1C	JU1D	JU1E	JU1F	JU1G	JU1H	JU1I	JU1J	JU1K	JU1L	JU1M	JU1N	JU1O	JU1P
Intermittent	0	IN	IN	IN	IN	IN	IN	IN	IN	IN	IN	IN	IN	IN	IN	IN	A
Exchange Low	1	IN	IN	IN	IN	IN	IN	IN	IN	IN	IN	IN	IN	IN	IN	IN	B
Exchange High	1	IN	IN	IN	IN	IN	IN	IN	IN	IN	IN	IN	IN	IN	IN	IN	B
Circulation low	1	IN	OUT	OUT	OUT	OUT	OUT	OUT	OUT	OUT	OUT	OUT	OUT	OUT	OUT	OUT	A
Circulation high	1	IN	OUT	OUT	OUT	OUT	OUT	OUT	OUT	OUT	OUT	OUT	OUT	OUT	OUT	OUT	A
Defrost Cycle	1	IN	OUT	OUT	OUT	OUT	OUT	OUT	OUT	OUT	OUT	OUT	OUT	OUT	OUT	OUT	A
Off	0	IN	OUT	OUT	OUT	OUT	OUT	OUT	OUT	OUT	OUT	OUT	OUT	OUT	OUT	OUT	A
0 = Relay coil is de-energized																	
1 = Relay coil is energized																	
NS = Not supported																	

FUNCTION TABLE B		JUMPER TABLE					MODEL	FUNCTION TABLE LETTER									
MODE	RELAY	JU1A	JU1B	JU1C	JU1D	JU1E	JU1F	JU1G	JU1H	JU1I	JU1J	JU1K	JU1L	JU1M	JU1N	JU1O	JU1P
Intermittent	0	IN	IN	IN	IN	IN	IN	IN	IN	IN	IN	IN	IN	IN	IN	IN	A
Exchange Low	1	IN	IN	IN	IN	IN	IN	IN	IN	IN	IN	IN	IN	IN	IN	IN	B
Exchange High	1	IN	IN	IN	IN	IN	IN	IN	IN	IN	IN	IN	IN	IN	IN	IN	B
Circulation low	NS	IN	OUT	OUT	OUT	OUT	OUT	OUT	OUT	OUT	OUT	OUT	OUT	OUT	OUT	OUT	NS
Circulation high	NS	IN	OUT	OUT	OUT	OUT	OUT	OUT	OUT	OUT	OUT	OUT	OUT	OUT	OUT	OUT	NS
Defrost Cycle	1	IN	OUT	OUT	OUT	OUT	OUT	OUT	OUT	OUT	OUT	OUT	OUT	OUT	OUT	OUT	NS
Off	0	IN	OUT	OUT	OUT	OUT	OUT	OUT	OUT	OUT	OUT	OUT	OUT	OUT	OUT	OUT	NS
0 = Relay coil is de-energized																	
1 = Relay coil is energized																	
NS = Not supported																	

NOTES

- THREE CONTROLS AVAILABLE. SEE THE INSTALLATION MANUAL (LOW VOLTAGE ONLY 12 VDC).
- PCB IONIZER IS AVAILABLE WITH AUTO CONTROL ONLY.
- FAN MOTOR 2 IS USED ONLY WITH VASBAB020, VCSBAB020, VCSBAB027.
- DAMPER MOTOR 2 IS USED ONLY WITH VCSBAB020, VCSBAB027.
- IF ANY OF THE ORIGINAL WIRE AS SUPPLIED, MUST BE REPLACED, USE THE SAME OR EQUIVALENT WIRE.

Fig. 31—Wiring Diagram

