

Installation, Operations and Maintenance Manual

NuShield-CI



NOTICE: This product is to be used only as directed. Read entire manual before use. Do not use unless properly installed.



Installation Location



WARNING: MAKE SURE POWER IS DISCONNECTED TO THE HVAC EQUIPMENT BEFORE INSTALLATION

Fan Inlet Mount

Internal magnets holding unit to fan inlet (shaft side). Use self-tapping screws to secure device, especially for high velocity applications or excessive vibration when using magnets.

Inside Wall/Cabinet Mount

Internal magnets holding unit to wall duct or air handler metal panel.

NOTE: Use Temperature - Maximum Ambient temperature in which unit shall be used: 140 degree F/ 60°C

Mechanical Installation

1. Ensure power to the HVAC equipment and the circuit the NuShield-CI will be connected to has been turned off.
2. The NuShield-CI is designed with universal mounting-either attach with screws or affix to the system with integral magnets. Mount near the fan inlet (shaft side) on a metal surface in the air handler, internal wall duct or external wall duct depending on what is best for the installation. IMPORTANT: If mounting on the fan housing, ensure the NuShield-CI is secured from fan vibration - use short length self-tapping screws so as not to impair operation of fan.
3. Install the NuShield-CI so that airflow is passing by both emitters at the same time in line with the airflow indicator on the top of the product. Make sure the unit is positioned so it obstructs as little airflow as possible.



CAUTION: ENSURE IN ALL INSTALLATIONS THAT OTHER METAL SURFACES/ WIRES ARE KEPT A MINIMUM OF TWO INCHES AWAY FROM THE TIP ENDS OF THE HIGH VOLTAGE EMITTERS TO PREVENT GROUNDING, LEADING TO PREMATURE FAILURE

Wiring

1. Confirm the power is off prior to wiring. Follow all local and national electrical and building codes.
2. Nu-Calgon recommends the NuShield-CI be powered constantly but it may be switched with the system or blower.
3. The NuShield-CI will self-adjust to voltages from 24VAC to 240VAC. Output and performance will not be effected by the choice of input voltage. Connect the power wires as follows:

Black = 24 - 240VAC

White = Neutral or L2

Green = Ground

Purple = Dry Contacts/BAS Alarm

4. Wire in BAS terminals (optional) The NuShield-CI is equipped with a set of dry contacts that are normally open and close when the NuShield-CI is on and has no faults. The contacts are rated up to 250VAC and 1A.

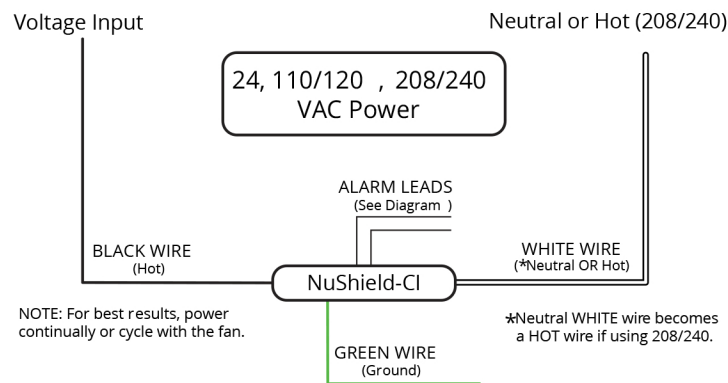

Operation



CAUTION! NEVER TOUCH BRUSHES WHILE OPERATING, SHOCK MAY OCCUR

Once powered, the unit initiates an internal check of all systems. If the auto cleaning wiper blade is not in the "home" position, it will move to the home position in series with the airflow and a green LED on the NuShield-CI will illuminate.

Cleaning Cycle

The NuShield-CI comes with a preset cleaning cycle designed to clean the brushes once every day. The cleaning process may be activated by pushing the clean button located on the side of the unit. To change the cycle frequency, press the cleaning cycle button once to start a cleaning cycle. While cleaning is in progress press and hold the cleaning cycle button for 3 seconds. The LED will start flashing. Pressing the cleaning cycle button again will change the days between cleaning. The frequency of flashes indicates the cleaning interval. The slowest pulse level = 1 day, next level = 3 days, next level = 5 days, fastest pulse = 10 days. Pressing the cycle button again will cycle back through the 4 different levels. If you do not push the button again for 5 seconds, the selected level is set.

Troubleshooting

1. Unit will not power up, LED not illuminated:
 - a. Confirm proper voltage is applied to the correct terminal(s).
 - a. Try an alternate power source. If using 24v try using 120v or vice versa.
2. If unit does not operate properly after verifying the above instructions please contact Nu-Calgon for additional assistance.



2611 Schuetz Rd. | St. Louis, MO 63043
Customer Service: 800-554-5499
www.nucalgon.com | www.nushieldair.com

Pat: www.gpspatents.com
CALGON is a licensed trade name (0921)

**Meets California ozone emissions
limit: CARB certified**



3 Year Limited Warranty:

The NuShield-CI offers a limited warranty for three years that covers any defects in material or workmanship under normal use. If you make a claim during the warranty period, you must provide proof of purchase and proof of proper installation by a licensed contractor for the warranty to be valid. The NuShield warranty does not cover labor, return shipping charges, damage from improper installation or improper voltage usage. The NuShield warranty begins on the date that the unit was purchased. Installation of your NuShield by any person other than a licensed contractor will void the warranty. Contact your local Nu-Calgon account manager or info@nucalgon.com with further questions.

