

Certified Drawing for 50HC-D09A2A5-0A0A0_SUBMITTAL

Project: 1.0 RTU Submittals for Website - Page 7
 Prepared By:

11/25/2019
 10:45AM

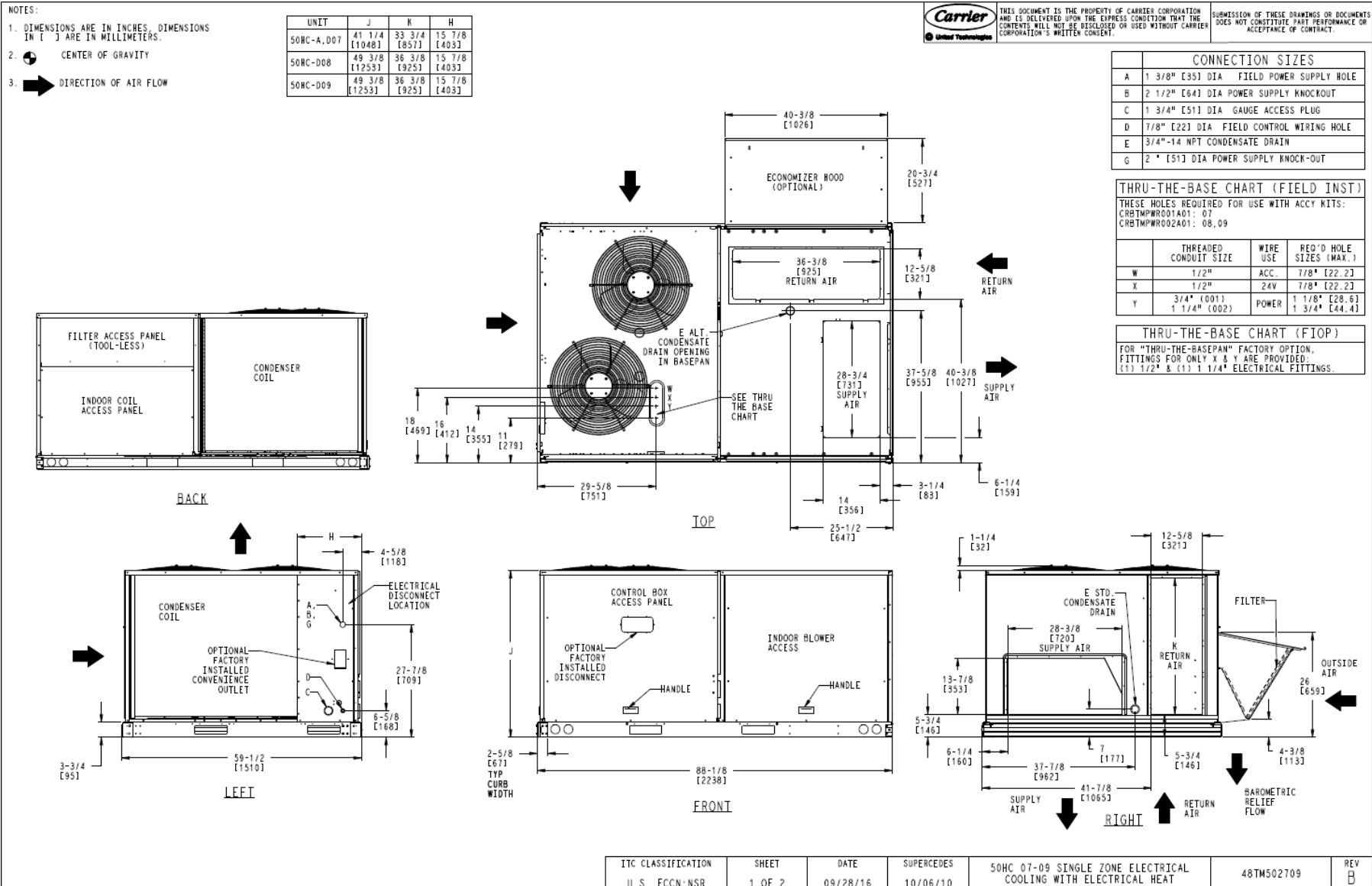

ITC CLASSIFICATION	SHEET	DATE	SUPERCEDES	50HC_07-09 SINGLE ZONE ELECTRICAL COOLING WITH ELECTRICAL HEAT	48TM502709	REV
U.S. ECCN: NSR	1 OF 2	09/28/16	10/06/10			B

Certified Drawing for 50HC-D09A2A5-0A0A0_SUBMITTAL

Project: 1.0 RTU Submittals for Website - Page 7
 Prepared By:

11/25/2019
 10:45AM

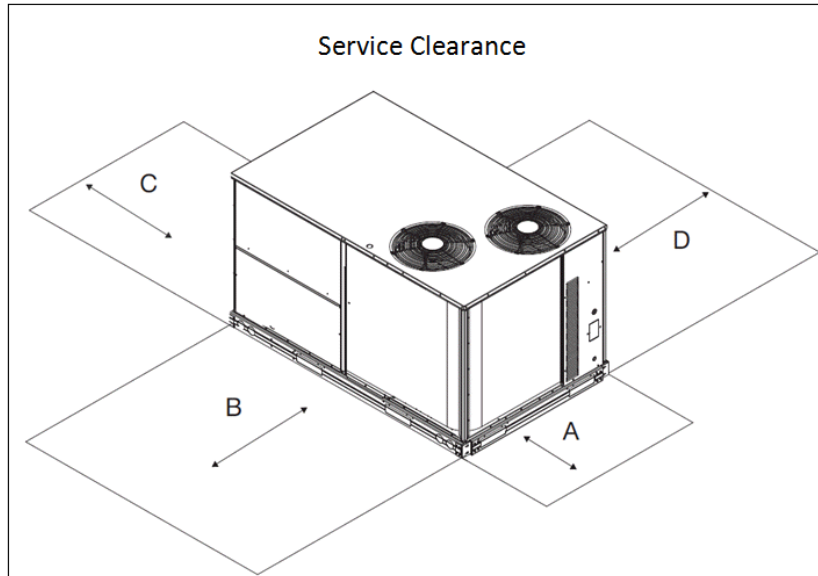

C11247

LOCATION	DIMENSION	CONDITION
A	48-in (1219 mm)	• Unit disconnect is mounted on panel
	36-in (914 mm)	• If dimension-B is 12-in (305 mm)
	18-in (457 mm)	• No disconnect, convenience outlet option • Recommended service clearance (use electric screwdriver)
	12-in (305 mm)	• Minimum clearance (use manual ratchet screwdriver)
B	36-in (914 mm)	• Unit has economizer
	12-in (305 mm)	• If dimension-A is 36-in (914 mm)
	Special	• Check for sources of flue products within 10-ft of unit fresh air intake hood
C	36-in (914 mm)	• Side condensate drain is used
	18-in (457 mm)	• Minimum clearance
D	48-in (1219 mm)	• No flue discharge accessory installed, surface is combustible material
	42-in (1067 mm)	• Surface behind servicer is grounded (e.g., metal, masonry wall, another unit)
	36-in (914 mm)	• Surface behind servicer is electrically non-conductive (e.g., wood, fiberglass)
	Special	• Check for adjacent units or building fresh air intakes within 10-ft of this unit's flue outlet

NOTE: Unit not designed to have overhead obstruction. Contact Application Engineering for guidance on any application planning overhead obstruction or vertical clearances.

Chassis 3-4a

Performance Summary For 50HC-D09A2A5-0A0A0_SUBMITTAL

Project: 1.0 RTU Submittals for Website - Page 7
Prepared By:

11/25/2019
10:45AM

Part Number:50HC-D09A2A6-0A0A0

ARI EER:.....12.20
Application EER (Rooftop Unit only):.....11.27
IEER:.....13.2

Base Unit Dimensions

Unit Length:.....88.1 in
Unit Width:.....59.5 in
Unit Height:.....49.4 in

Operating Weight

Base Unit Weight:.....860 lb
Medium Static Belt Drive:.....15 lb

Total Operating Weight:.....875 lb

Unit

Unit Voltage-Phase-Hertz:.....460-3-60
Air Discharge:.....Vertical
Fan Drive Type:.....Belt
Actual Airflow:.....3400 CFM
Site Altitude:.....0 ft

Cooling Performance

Condenser Entering Air DB:.....95.0 F
Evaporator Entering Air DB:.....80.0 F
Evaporator Entering Air WB:.....67.0 F
Entering Air Enthalpy:.....31.44 BTU/lb
Evaporator Leaving Air DB:.....57.9 F
Evaporator Leaving Air WB:.....57.4 F
Evaporator Leaving Air Enthalpy:.....24.67 BTU/lb
Unit Discharge Air DB:.....59.2 F
Unit Discharge Air WB:.....57.9 F
Unit Discharge Air Enthalpy:.....24.97 BTU/lb
Gross Cooling Capacity:.....103.62 MBH
Net Cooling Capacity:.....98.99 MBH
Gross Sensible Capacity:.....80.97 MBH
Net Sensible Capacity:.....76.34 MBH
Compressor Power Input:.....6.83 kW
Coil Bypass Factor:.....0.198

Supply Fan

External Static Pressure:.....1.00 in wg
Fan RPM:.....831
Fan Power:.....1.59 BHP
NOTE:.....Selected IFM RPM Range: 690 - 936

Electrical Data

Voltage Range:.....414 / 506
Compressor #1 RLA:.....6.2
Compressor #1 LRA:.....41
Compressor #2 RLA:.....6.2
Compressor #2 LRA:.....41
Indoor Fan Motor Type:.....MED
Indoor Fan Motor FLA:.....3.4
Power Supply MCA:.....19
Power Supply MOCP (Fuse or HACR):.....25
Disconnect Size FLA:.....20
Disconnect Size LRA:.....114
Electrical Convenience Outlet:.....None

Performance Summary For 50HC-D09A2A5-0A0A0_SUBMITTAL

Project: 1.0 RTU Submittals for Website - Page 7
 Prepared By:

11/25/2019
 10:45AM

Outdoor Fan [Qty / FLA (ea)]:..... **2 / 0.8**

Control Panel SCCR: 5kA RMS at Rated Symmetrical Voltage

Acoustics

Sound Power Levels, db re 10E-12 Watts

	Discharge	Inlet	Outdoor
63 Hz	90.4	86.2	88.6
125 Hz	84.5	79.0	85.0
250 Hz	70.3	65.8	81.6
500 Hz	68.6	64.7	79.5
1000 Hz	66.8	63.0	77.4
2000 Hz	63.8	57.3	74.1
4000 Hz	64.5	54.9	71.0
8000 Hz	60.7	49.3	66.3
A-Weighted	74.3	69.1	82.0

Advanced Acoustics

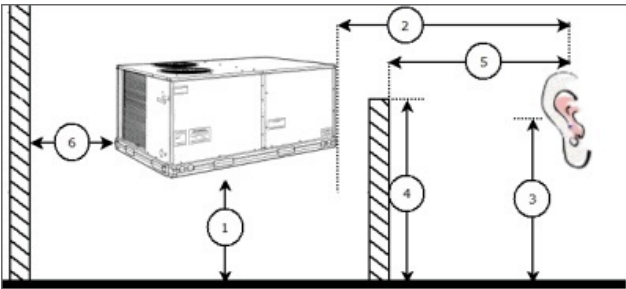

Advanced Acoustics Parameters

- 1. Unit height above ground:..... **30.0** ft
- 2. Horizontal distance from unit to receiver:..... **50.0** ft
- 3. Receiver height above ground:..... **5.7** ft
- 4. Height of obstruction:..... **0.0** ft
- 5. Horizontal distance from obstruction to receiver:..... **0.0** ft
- 6. Horizontal distance from unit to obstruction:..... **0.0** ft

Detailed Acoustics Information

Octave Band Center Freq. Hz	63	125	250	500	1k	2k	4k	8k	Overall
A	88.6	85.0	81.6	79.5	77.4	74.1	71.0	66.3	91.4 Lw
B	62.4	68.9	73.0	76.3	77.4	75.3	72.0	65.2	82.6 LwA
C	56.2	52.6	49.2	47.1	45.0	41.7	38.6	33.9	59.0 Lp
D	30.0	36.5	40.6	43.9	45.0	42.9	39.6	32.8	50.2 LpA

Legend

- A Sound Power Levels at Unit's Acoustic Center, Lw
- B A-Weighted Sound Power Levels at Unit's Acoustic Center, LwA
- C Sound Pressure Levels at Specific Distance from Unit, Lp
- D A-Weighted Sound Pressure Levels at Specific Distance from Unit, LpA

Performance Summary For 50HC-D09A2A5-0A0A0_SUBMITTAL

Project: 1.0 RTU Submittals for Website - Page 7
 Prepared By:

11/25/2019
 10:45AM

Calculation methods used in this program are patterned after the ASHRAE Guide; other ASHRAE Publications and the AHRI Acoustical Standards. While a very significant effort has been made to insure the technical accuracy of this program, it is assumed that the user is knowledgeable in the art of system sound estimation and is aware of the tolerances involved in real world acoustical estimation. This program makes certain assumptions as to the dominant sound sources and sound paths which may not always be appropriate to the real system being estimated. Because of this, no assurances can be offered that this software will always generate an accurate sound prediction from user supplied input data. If in doubt about the estimation of expected sound levels in a space, an Acoustical Engineer or a person with sound prediction expertise should be consulted.

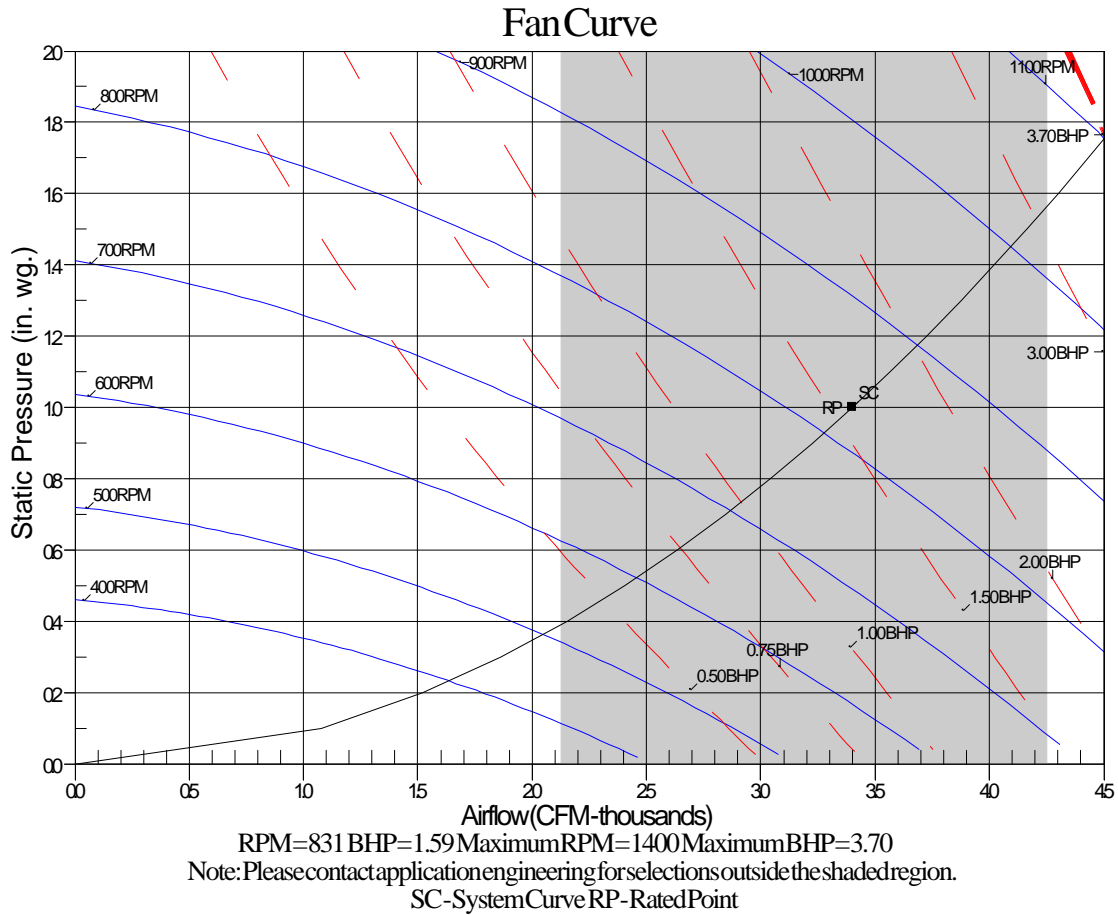



GUIDE SPECIFICATIONS – 50HC-D09A2A6-0A0A0

Cooling Only/Electric Heat Packaged Rooftop

HVAC Guide Specifications

Size: 009

Part 1: Schedules for Decentralized HVAC Equipment

Decentralized Unitary HVAC Equipment Schedule

- 1.01. Rooftop units schedule
 - A. Schedule is per the project specification requirements.

Part 2: HVAC Equipment Insulation

Decentralized, Rooftop Units:

- 2.01. Evaporator fan compartment:
 - A. Interior cabinet surfaces shall be insulated with a minimum 1/2-in. thick, minimum 1 1/2 lb density, flexible fiberglass insulation bonded with a phenolic binder, neoprene coated on the air side.
 - B. Insulation and adhesive shall meet NFPA 90A requirements for flame spread and smoke generation.
- 2.02. Electric heat compartment:
 - A. Aluminum foil-faced fiberglass insulation shall be used.
 - B. Insulation and adhesive shall meet NFPA 90A requirements for flame spread and smoke generation.

Part 3: Instrumentation and Control Devices for HVAC

Sensors and Transmitters

- 3.01. Thermostats
 - A. Thermostat must
 - 1. energize both "W" and "G" when calling for heat.
 - 2. have capability to energize 2 different stages of cooling, and 2 different stages of heating.
 - 3. include capability for occupancy scheduling.

Part 4: Electric and Electronic Control System for HVAC

Decentralized, Rooftop Units:

- 4.01. General:
 - A. Shall be complete with self-contained low-voltage control circuit protected by a resettable circuit breaker on the 24-v transformer side. Transformer shall have 75VA capability.
 - B. Shall utilize color-coded wiring.
 - C. Shall include a central control terminal board to conveniently and safely provide connection points for vital control functions such as: smoke detectors, phase monitor, economizer, thermostat, DDC control options, and low and high pressure switches.
 - D. Unit shall include a minimum of one 8-pin screw terminal connection board for connection of control wiring.
- 4.02. Safeties:
 - A. Compressor over-temperature, over current.

Guide Specification for 50HC-D09A2A5-0A0A0_SUBMITTAL

Project: 1.0 RTU Submittals for Website - Page 7
Prepared By:

11/25/2019
10:45AM

- B. Low-pressure switch.
 - 1. Units with 2 compressors shall have different sized connectors for the circuit 1 and circuit 2 low and high pressure switches. They shall physically prevent the cross-wiring of the safety switches between circuits 1 and 2.
 - 2. Low pressure switch shall use different color wire than the high pressure switch. The purpose is to assist the installer and service technician to correctly wire and or troubleshoot the rooftop unit.
- C. High-pressure switch.
 - 1. Units with 2 compressors shall have different sized connectors for the circuit 1 and circuit 2 low and high pressure switches. They shall physically prevent the cross-wiring of the safety switches between circuits 1 and 2.
 - 2. High pressure switch shall use different color wire than the low pressure switch. The purpose is to assist the installer and service technician to correctly wire and or troubleshoot the rooftop unit.

4.03. Automatic reset, motor thermal overload protector.

Part 5: Sequence of Operations for HVAC Controls

Decentralized, Rooftop Units:

5.01. INSERT SEQUENCE OF OPERATION

Part 6: Panel Air Filters

Decentralized, Rooftop Units:

6.01. Standard filter section

- A. Shall consist of factory-installed, low velocity, throwaway 2-in. thick fiberglass filters of commercially available sizes.
- B. Unit shall use only one filter size. Multiple sizes are not acceptable.
- C. Filters shall be accessible through an access panel with "no-tool" removal as described in the unit cabinet section of this specification (2381 19.13.H).

Part 7: Self-Contained Air Conditioners

Small-Capacity Self-Contained Air Conditioners

7.01. General

- A. Outdoor, rooftop mounted, electrically controlled, heating and cooling unit utilizing a(n) hermetic scroll compressor(s) for cooling duty and gas combustion for heating duty.
- B. Factory assembled, single-piece heating and cooling rooftop unit. Contained within the unit enclosure shall be all factory wiring, piping, controls, and special features required prior to field start-up.
- C. Unit shall use environmentally safe, Puronâ refrigerant.
- D. Unit shall be installed in accordance with the manufacturer's instructions.
- E. Unit must be selected and installed in compliance with local, state, and federal codes.

7.02. Quality Assurance

- A. Unit meets ASHRAE 90.1 minimum efficiency requirements.
- B. 3 phase units are Energy Star qualified.
- C. Unit shall be rated in accordance with AHRI Standards 210/240.
- D. Unit shall be designed to conform to ASHRAE 15, 2001.
- E. Unit shall be UL-tested and certified in accordance with ANSI Z21.47 Standards and UL-listed and certified under Canadian standards as a total package for safety requirements.
- F. Insulation and adhesive shall meet NFPA 90A requirements for flame spread and smoke generation.
- G. Unit casing shall be capable of withstanding 500-hour salt spray exposure per ASTM B117 (scribed specimen).
- H. Unit casing shall be capable of withstanding Federal Test Method Standard No. 141 (Method 6061) 5000-hour salt spray.
- I. Unit shall be designed in accordance with ISO 9001, and shall be manufactured in a facility registered by ISO 9001.
- J. Roof curb shall be designed to conform to NRCA Standards.
- K. Unit shall be subjected to a completely automated run test on the assembly line. The data for each unit will be stored at the factory, and must be available upon request.
- L. Unit shall be designed in accordance with UL Standard 1995, including tested to withstand rain.
- M. Unit shall be constructed to prevent intrusion of snow and tested to prevent snow intrusion into the control box up to 40 mph.

Guide Specification for 50HC-D09A2A5-0A0A0_SUBMITTAL

Project: 1.0 RTU Submittals for Website - Page 7
Prepared By:

11/25/2019
10:45AM

- N. Unit shake tested to assurance level 1, ASTM D4169 to ensure shipping reliability.
 - O. High Efficient Motors listed shall meet section 313 of the Energy Independence and Security Act of 2007 (EISA 2007).
- 7.03. Delivery, Storage, and Handling
- A. Unit shall be stored and handled per manufacturer's recommendations.
 - B. Lifted by crane requires either shipping top panel or spreader bars.
 - C. Unit shall only be stored or positioned in the upright position.
- 7.04. Project Conditions
- A. As specified in the contract.
- 7.05. Project Conditions
- A. As specified in the contract.
- 7.06. Operating Characteristics
- A. Unit shall be capable of starting and running at 125°F (52°C) ambient outdoor temperature, meeting maximum load criteria of AHRI Standard 210/240 or 340/360 at ± 10% voltage.
 - B. Compressor with standard controls shall be capable of operation down to 35°F (2°C), ambient outdoor temperatures. Accessory low ambient kits shall be available if operation below 35°F (2°C), is required. See below for head pressure control package or winter start kit.
 - C. Unit shall discharge supply air vertically or horizontally as shown on contract drawings.
 - D. Unit shall be factory configured for vertical supply & return configurations.
 - E. Unit shall be field convertible from vertical to horizontal airflow, no special kit required.
 - F. Unit shall be capable of mixed operation: vertical supply with horizontal return or horizontal supply with vertical return.
- 7.07. Electrical Requirements
- A. Main power supply voltage, phase, and frequency must match those required by the manufacturer.
- 7.08. Unit Cabinet
- A. Unit cabinet shall be constructed of galvanized steel, and shall be bonderized and coated with a pre-painted baked enamel finish on all externally exposed surfaces.
 - B. Unit cabinet exterior paint shall be: film thickness, (dry) 0.003 inches minimum, gloss (per ASTM D523, 60°F): 60, Hardness: H-2H Pencil hardness.
 - C. Evaporator fan compartment interior cabinet insulation shall conform to AHRI Standards 340/360 minimum exterior sweat criteria. Interior surfaces shall be insulated with a minimum 1/2-in. thick, 1 lb density, flexible fiberglass insulation, neoprene coated on the air side. Aluminum foil-faced fiberglass insulation shall be used in the heat compartment.
 - D. Base of unit shall have a minimum of four locations for thru-the-base gas and electrical connections (factory installed or field installed), standard.
 - E. Base Rail
 - 1. Unit shall have base rails on a minimum of 3 sides.
 - 2. Holes shall be provided in the base rails for rigging shackles to facilitate maneuvering and overhead rigging.
 - 3. Holes shall be provided in the base rail for moving the rooftop by fork truck.
 - 4. Base rail shall be a minimum of 16 gauge thickness.
 - F. Condensate pan and connections:
 - 1. Shall be an internally sloped condensate drain pan made of a non-corrosive material.
 - 2. Shall comply with ASHRAE Standard 62.
 - 3. Shall use a 3/4" -14 NPT drain connection, possible either through the bottom or end of the drain pan. Connection shall be made per manufacturer's recommendations.
 - G. Top panel:
 - 1. Shall be a single piece top panel.
 - H. Electrical Connections
 - 1. All unit power wiring shall enter unit cabinet at a single, factory-prepared, knockout location.
 - 2. Thru-the-base capability
 - a. Standard unit shall have a thru-the-base electrical location(s) using a raised, embossed portion of the unit basepan.

Guide Specification for 50HC-D09A2A5-0A0A0_SUBMITTAL

Project: 1.0 RTU Submittals for Website - Page 7
Prepared By:

11/25/2019
10:45AM

- b. Optional, factory-approved, water-tight connection method must be used for thru-the-base electrical connections.
 - c. No basepan penetration, other than those authorized by the manufacturer, is permitted.
- I. Component access panels (standard)
1. Cabinet panels shall be easily removable for servicing.
 2. Unit shall have one factory installed, tool-less, removable, filter access panel.
 3. Panels covering control box, indoor fan, indoor fan motor, gas components (where applicable), and compressors shall have molded composite handles.
 4. Handles shall be UV modified, composite, permanently attached, and recessed into the panel.
 5. Screws on the vertical portion of all removable access panel shall engage into heat resistant, molded composite collars.
 6. Collars shall be removable and easily replaceable using manufacturer recommended parts.

7.09. Coils

A. Standard Aluminum Fin/Copper Tube Coils:

1. Standard evaporator and condenser coils shall have aluminum lanced plate fins mechanically bonded to seamless internally grooved copper tubes with all joints brazed.
2. Evaporator coils shall be leak tested to 150 psig, pressure tested to 450 psig, and qualified to UL 1995 burst test at 1775 psig.
3. Condenser coils shall be leak tested to 150 psig, pressure tested to 650 psig, and qualified to UL 1995 burst test at 1980 psig.

7.10. Refrigerant Components

A. Refrigerant circuit shall include the following control, safety, and maintenance features:

1. Thermostatic Expansion Valve (TXV) shall help provide optimum performance across the entire operating range. Shall contain removable power element to allow change out of power element and bulb without removing the valve body.
2. Refrigerant filter drier.
3. Service gauge connections on suction and discharge lines.

B. Compressors

1. Unit shall use one fully hermetic, scroll compressor for each independent refrigeration circuit.
2. Models shall be available with 2 compressor/2-stage cooling.
3. Compressor motors shall be cooled by refrigerant gas passing through motor windings.
4. Compressors shall be internally protected from high discharge temperature conditions.
5. Compressors shall be protected from an over-temperature and over-ampereage conditions by an internal, motor overload device.
6. Compressor shall be factory mounted on rubber grommets.
7. Compressor motors shall have internal line break thermal, current overload and high pressure differential protection.
8. Crankcase heaters shall not be required for normal operating range, unless provided by the factory.

7.11. Filter Section

- A. Filters access is specified in the unit cabinet section of this specification.
- B. Filters shall be held in place by a pivoting filter tray, facilitating easy removal and installation.
- C. Shall consist of factory-installed, low velocity, throw-away 2-in. thick fiberglass filters.
- D. Filters shall be standard, commercially available sizes.
- E. Only one size filter per unit is allowed.

7.12. Evaporator Fan and Motor

A. Evaporator fan motor:

1. Shall have permanently lubricated bearings.
2. Shall have inherent automatic-reset thermal overload protection or circuit breaker.
3. Shall have a maximum continuous bhp rating for continuous duty operation; no safety factors above that rating shall be required.

B. Belt-driven Evaporator Fan:

1. Belt drive shall include an adjustable-pitch motor pulley.

Guide Specification for 50HC-D09A2A5-0A0A0_SUBMITTAL

Project: 1.0 RTU Submittals for Website - Page 7

11/25/2019

Prepared By:

10:45AM

2. Shall use sealed, permanently lubricated ball-bearing type.
3. Blower fan shall be double-inlet type with forward-curved blades.
4. Shall be constructed from steel with a corrosion resistant finish and dynamically balanced.
5. Standard on all 04-07 size and 04-06 size models with Humidi-MiZer. Optional on all 04-06 3-phase models.

7.13. Condenser Fans and Motors

A. Condenser fan motors:

1. Shall be a totally enclosed motor.
2. Shall use permanently lubricated bearings.
3. Shall have inherent thermal overload protection with an automatic reset feature.
4. Shall use a shaft-down design.

B. Condenser Fans:

1. Shall be a direct-driven propeller type fan.
2. Shall have galvalum blades riveted to corrosion-resistant steel spiders and shall be dynamically balanced.

7.14. Special Features, Options and Accessories