



Installation, Start-Up, and Service Instructions

CONTENTS

	Page
SAFETY CONSIDERATIONS	2
GENERAL	3
PRE-INSTALLATION	3
• INSPECTION	
• STORAGE	
INSTALLATION	3
Step 1 — Check Jobsite	3
• HORIZONTAL UNIT (50PSH)	
• VERTICAL UNITS (50PSV)	
• INSTALLATION GUIDELINES (ALL UNITS)	
Step 2 — Check Unit	7
• INSPECT UNIT	
Step 3 — Locate Unit	7
• PROTECTION	
Step 4 — Mount the Unit	8
• DUCT FLANGES	
• VERTICAL UNITS (50PSV)	
• HORIZONTAL UNIT (50PSH)	
Step 5 — Check Duct System	9
• HORIZONTAL SUPPLY AIR CONFIGURATION CONVERSION	
Step 6 — Install Condensate Drain	9
Step 7 — Pipe Connections	10
• WATER LOOP APPLICATIONS	
• GROUND-WATER APPLICATIONS	
• GROUND-LOOP APPLICATIONS	
• INSTALLATION OF SUPPLY AND RETURN HOSE KIT	
• AQUASTAT BULB INSTALLATION	
• INSTALLATION OF HOT WATER GENERATOR OPTION	
Step 8 — Wire Field Power Supply	14
• HIGH VOLTAGE	
Step 9 — Wire Control Connections	39
• COMPLETE C AND DELUXE D CONTROL	
• ECM INTERFACE THERMOSTAT CONNECTIONS	
• THERMOSTAT AND DDC SENSORS	
• HOT GAS REHEAT CONTROL	
• AUXILIARY RELAY (DELUXE D ONLY)	
• ENERGY MANAGEMENT SWITCH (DELUXE D ONLY)	
• BOILERLESS HEAT CONTROL (DELUXE D ONLY)	
• ALARM OUTPUT (ALL UNITS)	
• WSHP OPEN CONTROL	
• CONTROL TRANSFORMER	
Step 10 — Configure Unit Control Components ..	40
• UNIT PROTECTION MODULE (UPM)	
• WATERSIDE ECONOMIZER (ETO)	
• BOILERLESS HEAT CONTROL (DELUXE D ONLY)	
PRE-START-UP	42
System Checkout	42
• CLEAN AIR COIL	
Set Blower Motor Speed	42
• PERMANENT SPLIT CAPACITOR (PSC) MOTOR	
• CONSTANT TORQUE (ECM) MOTOR	
• CONSTANT AIRFLOW (ECM) MOTOR	
System Flushing and Filling	45
System Flow	45
• FLOW VERIFICATION	
• FLOW REGULATION	
• ANTIFREEZE	
• FREEZE PROTECTION SELECTION	
START-UP	46
Operating Limits	46
• ENVIRONMENT	
• POWER SUPPLY	
• UNIT STARTING CONDITIONS	
Start-Up Procedure	46
• SCROLL COMPRESSOR ROTATION	
• COOLING MODE START-UP	
• HEATING MODE START-UP	
OPERATION	49
Power Up Mode	49
Unit Protection Module (UPM)	49
Units with Complete C or Deluxe D Controls	50
• STANDBY	
• COOLING	
• HOT GAS REHEAT (OPTIONAL FOR COMPLETE C OR DELUXE D CONTROLS)	
• WATERSIDE ECONOMIZER (OPTIONAL FOR COMPLETE C OR DELUXE D CONTROLS)	
• TWO WAY WATER FLOW CONTROL VALVE (OPTIONAL)	
• BOILERLESS HEAT (DELUXE D ONLY)	
• PUMP/VALVE RELAY (DELUXE D ONLY)	
Units with WSHP Open Controls	50
• COOLING	
• REVERSE CYCLE HEATING	
• TWO POSITION OA DAMPER	
• MODULATING OA DAMPER WITH DCV	
• AUXILIARY MODULATING HOT WATER / STEAM HEATING REHEAT	
• 2-POSITION HOT WATER / STEAM HEATING REHEAT	
• SINGLE STAGE ELECTRIC AUXILIARY HEAT	
• AUTOMATIC FAN SPEED CONTROL	
• FAN SPEED CONTROL - DURING HEATING	
• FAN SPEED CONTROL - DURING COOLING	
• MODULATING WATER ECONOMIZER CONTROL	
• 2-POSITION WATER ECONOMIZER CONTROL	
• POWER FAIL RESTART DELAY	
• SUPPLY AIR TEMPERATURE MONITORING / CONTROL / ALARM	
• DEHUMIDIFICATION	
• SPACE TEMPERATURE ALARMS	
• CONDENSER WATER TEMPERATURE MONITORING / CONTROL / ALARM	
• HIGH CONDENSATE / OVERFLOW ALARM	
• FILTER STATUS ALARM	

- COMPRESSOR FAULT/LOCKOUT ALARM
- INSUFFICIENT VENTILATION ALARM
- RELATIVE HUMIDITY ALARM
- TIME SCHEDULES
- HOLIDAY SCHEDULES
- OVERRIDE SCHEDULES

SERVICE	53
Filters	53
Water Coil	54
Condensate Drain Pans	54
Refrigerant System	54
Compressor	54
Fan Motors	54
Condensate Drain Cleaning	54
Air Coil Cleaning	54
Condenser Cleaning	54
• GRAVITY FLOW METHOD	
• FORCED CIRCULATION METHOD	
Checking System Charge	55
Refrigerant Charging	55
Air Coil Fan Motor Removal	55
TROUBLESHOOTING	55
• UNIT PROTECTION MODULE (UPM)	
Freeze Protection Sensors	57
Thermostatic Expansion Valves	58
• TXV FAILURE	
50PSH,PSV START-UP CHECKLIST	CL-1

SAFETY CONSIDERATIONS

Installation and servicing of air-conditioning equipment can be hazardous due to system pressure and electrical components. Only trained and qualified service personnel should install, repair, or service air-conditioning equipment.

Untrained personnel can perform basic maintenance functions of cleaning coils and filters and replacing filters. All other operations should be performed by trained service personnel. When working on air-conditioning equipment, observe precautions in the literature, tags and labels attached to the unit, and other safety precautions that may apply.

Improper installation, adjustment, alteration, service, maintenance, or use can cause explosion, fire, electrical shock or other conditions which may cause personal injury or property damage. Consult a qualified installer, service agency, or your distributor or branch for information or assistance. The qualified installer or agency must use factory-authorized kits or accessories when servicing or repairing this product. Refer to the individual instructions packaged with the kits or accessories when installing.

Follow all safety codes. Wear safety glasses and work gloves. Use quenching cloth for brazing operations. Have fire extinguisher available. Read these instructions thoroughly and follow all warnings or cautions attached to the unit. Consult local building codes and the National Electrical Code (NEC) for special installation requirements.

Understand the signal words — DANGER, WARNING, and CAUTION. DANGER identifies the most serious hazards which will result in severe personal injury or death. WARNING signifies hazards that could result in personal injury or death. CAUTION is used to identify unsafe practices, which would result in minor personal injury or product and property damage.

It is important to recognize safety information. This is the safety-alert symbol (⚠). When you see this symbol on the unit and in instructions or manuals, be alert to the potential for personal injury.

IMPORTANT: Read the entire instruction manual before starting installation.

⚠ WARNING

Electrical shock can cause personal injury and death. Shut off all power to this equipment during installation. There may be more than one disconnect switch. Tag all disconnect locations to alert others not to restore power until work is completed.

GENERAL

This installation and start-up instructions literature is for Aqua-zone™ single-stage water source heat pump systems.

Water source heat pumps (WSHPs) are single-package horizontally and vertically mounted units with electronic controls designed for year-round cooling and heating.

IMPORTANT: The installation of water source heat pump units and all associated components, parts, and accessories which make up the installation shall be in accordance with the regulations of ALL authorities having jurisdiction and MUST conform to all applicable codes. It is the responsibility of the installing contractor to determine and comply with ALL applicable codes and regulations.

PRE-INSTALLATION

INSPECTION

Upon receipt of shipment, carefully check the shipment against the bill of lading. Make sure all units have been received. Inspect the carton or crating of each unit, and inspect each unit for damage on both the interior and exterior. Ensure the shipping company makes proper notation of any shortages or damage on all copies of the freight bill.

Concealed damage not discovered during unloading must be reported to the shipping company within 5 days of receipt of shipment.

NOTE: It is the responsibility of the purchaser to file all necessary claims with the shipping company.

STORAGE

If the equipment is not needed for immediate installation upon its arrival at the job site, it should be left in its shipping carton and stored in a clean, dry area between 50 and 95°F. Units must only be stored or moved in the normal upright position as indicated by the UP arrows on each carton at all times. If unit stacking is required, stack units as follows: vertical units less than 6 tons, no more than two high; horizontal units less than 6 tons, no more than three high. Do not stack units larger than 6 tons.

INSTALLATION

Step 1 — Check Jobsite

Installation, operation and maintenance instructions are provided with each unit. Before unit start-up, read all manuals and become familiar with the unit and its operation. Thoroughly check out the system before operation. Complete the inspections and instructions listed below to prepare a unit for installation. See Table 1 for unit physical data.

CAUTION

To avoid equipment damage, do not use these units as a source of heating or cooling during the construction process. The mechanical components and filters used in these units quickly become clogged with construction dirt and debris which may cause system damage.

IMPORTANT: This equipment is designed for indoor installation ONLY. Extreme variations in temperature, humidity and corrosive water or air will adversely affect the unit performance, reliability and service life.

HORIZONTAL UNIT (50PSH)

Horizontal units are designed for indoor installation only. Be sure to allow adequate space around the unit for servicing. See Fig. 1 for overall unit dimensions.

VERTICAL UNITS (50PSV)

Vertical units are designed for indoor installation only. While vertical units are typically installed in a floor-level closet or a small mechanical room, the unit access guidelines for these units are very similar to those described for horizontal units. See Fig. 2 for overall dimensions.

**Table 1 — Physical Data
007-024**

50PS UNIT SIZE	007	009	012	015	018	024
Compressor Type	Rotary					Scroll
Maximum Water Working Pressure (psig)	400 ^a					
Standard Fan Motor and Blower						
Fan Motor Type	PSC			ECM Constant Torque		
Fan Motor (hp)	1/10	1/10	1/10	1/3	1/3	1/2 ^b / 1/3
Blower Wheel Size (Diameter x Width) (in.)	4.5 x 4.5	4.5 x 4.5	5.5 x 5.5	5.5 x 4.5	9 x 7	9 x 7
ECM Const CFM Fan Motor						
Fan Motor Type	NA	NA	NA	ECM Constant CFM		
Fan Motor (hp)	NA	NA	NA	1/3	1/3	1/3
Water Connection Size						
FPT (in.)	3/4	3/4	3/4	3/4	3/4	3/4
Coaxial Coil Volume (gal.)	0.15	0.15	0.31	0.31	0.31	0.48
Vertical Cabinet						
Refrigeration Charge (oz)	31	31	30	46	34	65
Air Coil Dimensions (H x L) (in.)	12 x 16.5	12 x 16.5	16 x 16.5	16.5 x 20	16.5 x 20	24 x 21
Standard Filter - 1-in. Throwaway (H x L) (in.)	15 x 20	15 x 20	18 x 20	20 x 20	20 x 20	24 x 24
Operating Weight (lb)	140	154	166	191	195	229
Shipping Weight (lb)	160	174	186	208	212	242
Horizontal Cabinet						
Refrigeration Charge (oz)	31	31	35	35	35	65
Air Coil Dimensions (H x L) (in.)	12 x 16.5	12 x 16.5	16 x 16.5	18 x 18.5	18 x 18.5	18 x 28
Standard Filter - 1-in. Throwaway (H x L) (in.)	15 x 20	15 x 20	18 x 20	18 x 20	18 x 20	20 x 30
Operating Weight (lb)	165	172	173	190	198	307
Shipping Weight (lb)	185	192	205	218	222	340

030-070

50PS UNIT SIZE	030	036	042	048	060	070
Compressor Type	Scroll					
Maximum Water Working Pressure (psig)	400 ^a					
Standard Fan Motor and Blower						
Fan Motor Type	ECM Constant Torque					
Fan Motor (hp)	1/2	3/4	3/4	3/4	1	1
Blower Wheel Size (Diameter x Width) (in.)	9 x 7	9 x 7	10 x 8	10 x 8	11 x 9	11 x 9
ECM Const CFM Fan Motor						
Fan Motor Type	ECM Constant CFM					
Fan Motor (hp)	1/2	3/4	3/4	3/4	1	1
Water Connection Size						
FPT (in.)	1	1	1	1	1	1
Coaxial Coil Volume (gal.)	0.39	0.62	0.62	0.62	0.62	0.85
Vertical Cabinet						
Refrigeration Charge (oz)	71	65 Cu / 68 CuNi	83 Cu / 86 CuNi	83 Cu / 86 CuNi	90 Cu / 93 CuNi	127
Air Coil Dimensions (H x L) (in.)	24 x 27	24 x 27	32 x 27	32 x 27	40 x 27	40 x 27
Standard Filter - 1-in. Throwaway (H x L) (in.)	24 x 30	24 x 30	16 x 30 (2)	16 x 30 (2)	20 x 30 (2)	20 x 30 (2)
Operating Weight (lb)	269	281	334	340	396	444
Shipping Weight (lb)	292	304	360	366	422	470
Horizontal Cabinet						
Refrigeration Charge (oz)	71	65 Cu / 68 CuNi	83 Cu / 86 CuNi	83 Cu / 86 CuNi	90 Cu / 93 CuNi	127
Air Coil Dimensions (H x L) (in.)	20 x 32.5	20 x 32.5	20 x 43.25	20 x 43.25	20 x 54	20 x 54
Standard Filter - 1-in. Throwaway (H x L) (in.)	20 x 34.5	20 x 34.5	20 x 24 (2)	20 x 24 (2)	20 x 28 (2)	20 x 28 (2)
Operating Weight (lb)	358	369	400	405	452	494
Shipping Weight (lb)	404	415	465	470	520	562

NOTE(S):

- a. 300 psig when unit is built with the 2-way solenoid valve option.
- b. 2 ton units at 460v and Constant Torque ECM motor will have a 1/2 HP fan motor rather than a 1/3 HP motor.

LEGEND

- ECM — Electronically Commutated Motor
- NA — Not Applicable
- PSC — Permanent Split Capacitor

Horizontal Dimensions

UNIT	A	B	C	D	E	F	G	H	J	K	M	N	P	Q	FILTER RACK HEIGHT	R/A DUCT FLANGE HEIGHT	CONDENSER WATER CONNECTIONS	RECOMMENDED REPLACEMENT NOMINAL FILTER SIZE
	WIDTH	DEPTH*	HEIGHT	CAB END TO FILTER RACK	R/A DUCT WIDTH	CAB FRONT TO FILTER RACK	WATER IN	WATER OUT	SIDE TO DISC.	DISC. WIDTH	TOP TO DISC.	DISC. HEIGHT	END TO DISC.	TOP TO DISC.				
007	21.75	43.25	16.75	0.50	20.25	22.25	2.25	13.87	3.50	11.75	4.62	7.75	3.50	4.62	15.00	13.00	3/4 FPT	15 x 20 x 1
009	21.75	43.25	16.75	0.50	20.25	22.25	2.25	13.87	3.50	11.75	4.62	7.75	3.50	4.62	15.00	13.00	3/4 FPT	15 x 20 x 1
012	22.25	45.25	19.75	0.62	20.25	24.25	2.50	12.50	3.62	11.75	7.12	7.75	3.62	4.75	18.00	16.00	3/4 FPT	18 x 20 x 1
015	22.25	45.25	19.75	1.62	20.25	23.25	2.50	12.50	2.75	13.75	3.12	13.75	2.75	2.87	18.00	16.00	3/4 FPT	18 x 20 x 1
018	22.25	45.25	19.75	1.62	20.25	23.25	2.50	12.50	2.75	13.75	3.12	13.75	2.75	2.87	18.00	16.00	3/4 FPT	18 x 20 x 1
024	26.25	54.75	22.00	1.25	30.25	23.00	2.62	15.12	3.75	13.75	2.12	15.75	3.75	4.25	20.12	18.00	3/4 FPT	20 x 30 x 1
030	30.25	68.25	22.00†	2.00	35.00	31.25	2.50	13.25	4.50	15.75	4.00	15.75	4.50	2.25	20.12	18.00	1 FPT	20 x 34.5 x 1
036	30.25	68.25	22.00†	2.00	35.00	31.25	2.50	13.25	4.50	15.75	4.00	15.75	4.50	2.25	20.12	18.00	1 FPT	20 x 34.5 x 1
042	30.25	79.00	22.00†	0.75	48.25	29.62	2.75	13.25	4.50	17.75	2.25	17.75	4.50	2.12	20.12	18.00	1 FPT	20 x 24 x 1 (2)
048	30.25	79.00	22.00†	0.75	48.25	29.62	2.75	13.25	4.50	17.75	2.25	17.75	4.50	2.12	20.12	18.00	1 FPT	20 x 24 x 1 (2)
060	30.25	89.25	22.00†	1.87	56.25	31.00	2.62	13.25	4.50	17.75	2.25	17.75	4.50	2.12	20.12	18.00	1 FPT	20 x 28 x 1 (2)
070	30.25	89.25	22.00†	1.87	56.25	31.00	5.75	17.75	4.87	17.75	2.62	17.75	4.87	1.75	20.12	18.00	1 FPT	20 x 28 x 1 (2)

* When WSHP Open controller is installed increase depth by 2.6 inches.

† Total unit height is 22.75 with base rails for 030-070 units.

** Condensate drain connection is 3/4 in. FPT.

NOTES:

1. All dimensions in inches unless otherwise noted. All dimensions within ± 0.125 -in. Specifications subject to change without notice.
2. Unit sizes 015-070 discharge locations can be field converted between back discharge and side discharge.
3. Airflow configurations determined when facing panel with water connections.

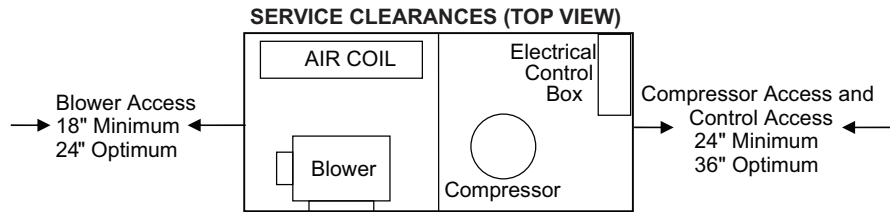
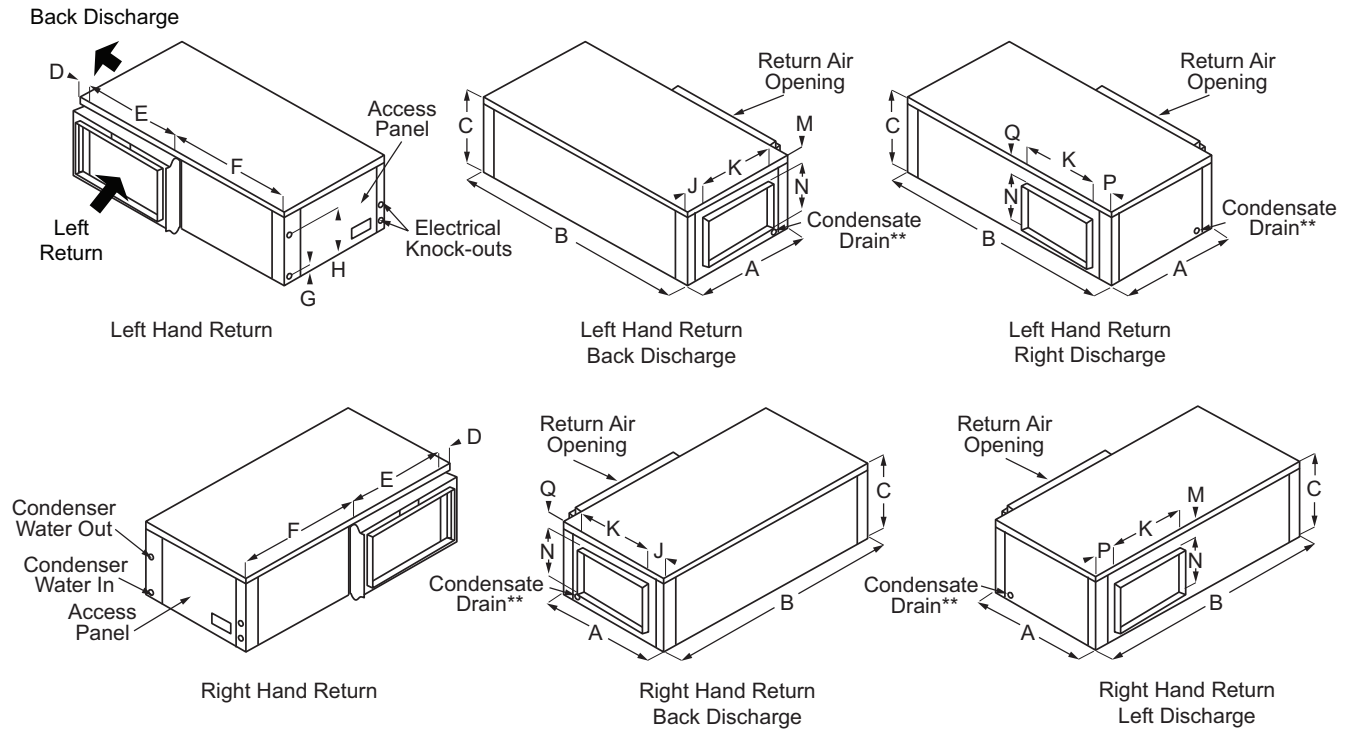

NOTE: The local electric codes may require 36-in. or more clearance at the electrical control box.

Fig. 1 — 50PSH007-070 Dimensional Data

Vertical Dimensions

UNIT	A	B	C	D	E	F	G	H	J	K	M	N	P	Q	CONDENSER WATER CONNECTIONS	RECOMMENDED REPLACEMENT NOMINAL FILTER SIZE
	WIDTH	DEPTH*	HEIGHT	DISCHARGE DEPTH	DISCHARGE WIDTH	CABINET EDGE TO DISCHARGE	LEFT SIDE TO DISC.	WATER IN	BOTTOM TO COND. DRAIN	WATER OUT	R/A DUCT WIDTH	R/A DUCT FLANGE HEIGHT	FILTER RACK HEIGHT	RIGHT SIDE TO DISC.		
007	21.75	21.75	32.75	11.75	7.75	5.00	8.50	2.25	8.00	13.75	18.00	13.00	15.00	5.32	3/4 FPT	15 x 20 x 1
009	21.75	21.75	32.75	11.75	7.75	5.00	8.50	2.25	8.00	13.75	18.00	13.00	15.00	5.32	3/4 FPT	15 x 20 x 1
012	21.75	21.75	32.75	11.75	7.75	5.00	8.50	2.62	7.50	12.50	18.00	16.00	18.00	5.32	3/4 FPT	18 x 20 x 1
015	21.75	21.75	39.25	13.75	13.75	4.00	6.12	2.25	7.50	12.25	18.00	18.00	20.00	4.00	3/4 FPT	20 x 20 x 1
018	21.75	21.75	39.25	13.75	13.75	4.00	6.12	2.25	7.50	12.25	18.00	18.00	20.00	4.00	3/4 FPT	20 x 20 x 1
024	21.75	26.25	47.25	13.75	15.75	6.25	4.87	2.50	8.75	15.00	22.00	22.00	24.00	4.00	3/4 FPT	24 x 24 x 1
030	24.25	33.50	47.25	15.75	15.75	8.87	7.00	2.50	8.50	14.50	28.00	22.00	24.00	4.00	1 FPT	24 x 30 x 1
036	24.25	33.50	47.25	15.75	15.75	8.87	7.00	2.50	8.50	14.50	28.00	22.00	24.00	4.00	1 FPT	24 x 30 x 1
042	26.25	33.50	58.25	17.75	17.75	7.87	6.75	3.25	8.50	13.25	28.00	30.00	32.00	4.00	1 FPT	16 x 30 x 1 (2)
048	26.25	33.50	58.25	17.75	17.75	7.87	6.75	3.25	8.50	13.25	28.00	30.00	32.00	4.00	1 FPT	16 x 30 x 1 (2)
060	26.25	33.50	66.25	17.75	17.75	7.87	7.00	3.25	8.50	13.25	28.00	38.00	40.00	4.00	1 FPT	20 x 30 x 1 (2)
070	26.25	33.50	66.25	17.75	17.75	7.87	7.25	4.25	10.00	17.00	28.00	38.00	40.00	3.00	1 FPT	20 x 30 x 1 (2)

* When WSH Open controller is installed increase depth by 2.6 inches.

** Condensate drain connection is 3/4-in. FPT.

NOTES:

1. All dimensions in inches unless otherwise noted. All dimensions within ± 0.125 -in. Specifications subject to change without notice.
2. Airflow configuration determined when facing panel with water connections.

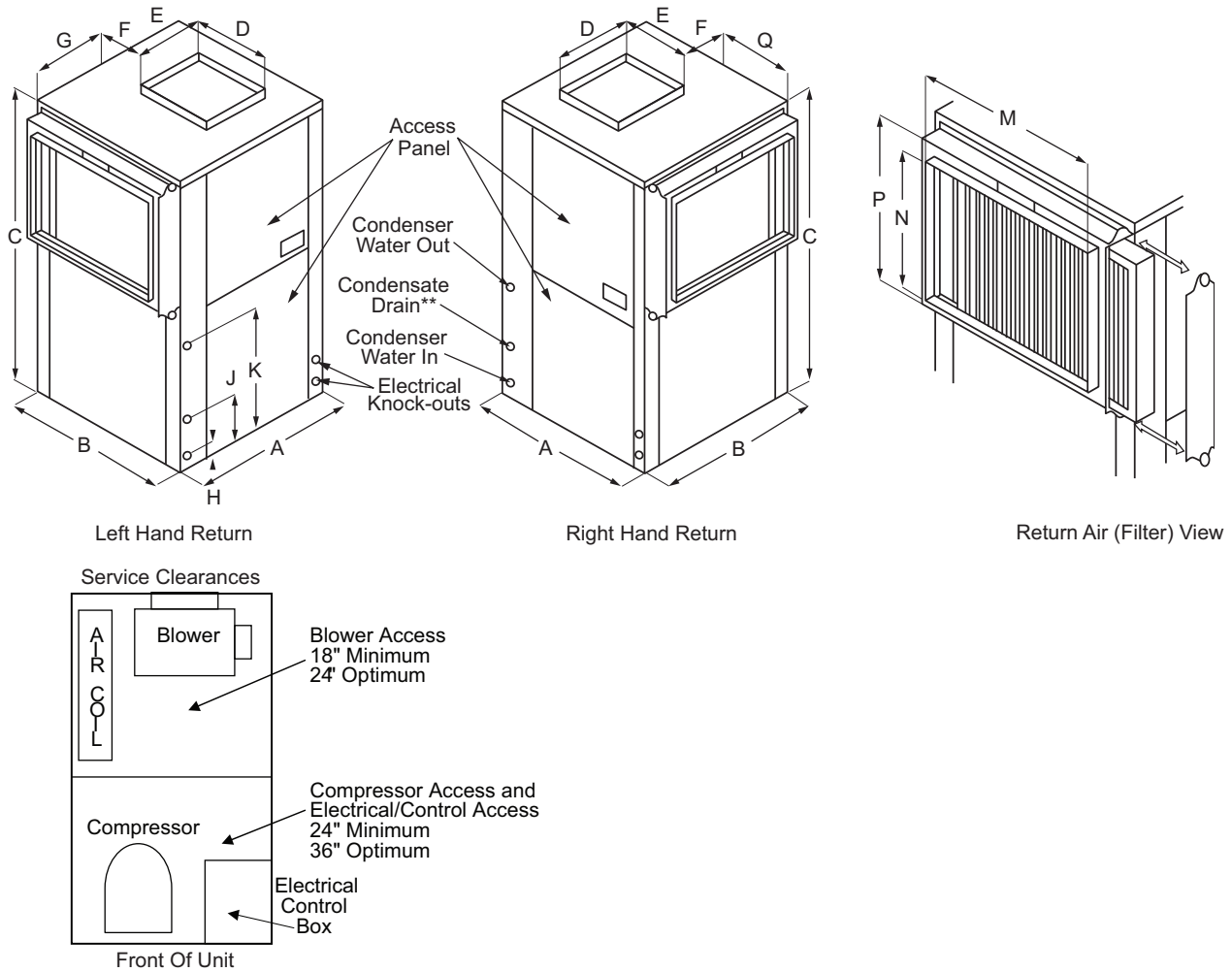

NOTE: The local electric codes may require 36-in. or more clearance at the electrical control box.

Fig. 2 — 50PSV007-070 Unit Dimensions

INSTALLATION GUIDELINES (ALL UNITS)

1. Be sure that the location chosen for unit installation provides ambient temperatures maintained above freezing.
2. Be sure the installation location is isolated from sleeping areas, private offices and other acoustically sensitive spaces.
3. Be sure unit is mounted at a height sufficient to provide an adequate slope of the condensate lines. If an appropriate slope cannot be achieved, a field-supplied condensate pump may be required.
4. On horizontal units, allow adequate room below the unit for condensate drain trap and do not locate the unit above supply piping.
5. Provide sufficient space for duct connection. Do not allow the weight of the ductwork to rest on the unit.
6. Provide adequate clearance for filter replacement and drain pan cleaning. Do not allow piping, conduit, etc. to block filter access.
7. Provide sufficient access to allow maintenance and servicing of the blower and blower motor, compressor, refrigerant circuit, controls, and coils.
8. For units with free return (non-ducted), provide adequate space for proper return airflow. For units installed in closets or mechanical rooms, provide sufficient return grill area for proper airflow.
9. Provide ready access to water valves and fittings, and screwdriver access to unit side panels, discharge collar, and all electrical connections.
10. Where access to side panels is limited, pre-removal of the control box side mounting screws may be necessary for future servicing.
11. For units that are installed in enclosed spaces (such as furred in closets or behind finished ceilings), provide access panels to allow for the installation, maintenance, service, and removal of the unit.

IMPORTANT: It is the installing contractor's responsibility to ensure that all equipment is installed with proper access for service, start-up, installation of accessories, configuration of control and other components, and equipment removal in accordance with Carrier's recommended service clearances and installation instructions. Please refer to the Carrier Commercial WSHP Warranty Statement (document number 04-570008-01) for details on warranty exclusions regarding equipment, access, removal and clearances.

Step 2 — Check Unit

Upon receipt of equipment at the jobsite, inspect the carton or crating of each unit, and inspect each unit for damage on both the interior and exterior. Note any damage and contact your local equipment sales office.

CAUTION

EQUIPMENT DAMAGE HAZARD

DO NOT store or install units in corrosive environments or in locations subject to temperature or humidity extremes (e.g., attics, garages, rooftops, etc.). Corrosive conditions and high temperature or humidity can significantly reduce performance, reliability, and service life. Always move units in an upright position. Tilting units on their sides may cause equipment damage.

INSPECT UNIT

To prepare the unit for installation, complete the procedures listed below:

1. Verify that the correct unit has been received. Check the unit capacity (tonnage), voltage, orientation, and configuration.
2. Compare the electrical data on the unit nameplate with to verify the jobsite power feed (voltage, amperage, MCA) and power protection (MOCP).
3. Verify that the unit is the correct model for the entering water temperature of the job (standard or extended range)
4. Remove the unit packaging, keeping the unit attached to the shipping pallet. Do not destroy packaging. Save for re-installation on the unit if the unit will not be fully installed.
5. Open a unit access panel. Verify that the refrigerant tubing is free of kinks or dents, and that it does not touch other unit components.
6. Check the water piping and piping connections to make sure they are free from defects, kinks, dents, and appear to be water tight. Verify system operating water pressure.
7. Inspect the blower assembly. Verify that the blower has not come loose during shipping. Verify clearance between the blower wheel and the blower housing. Verify free blower rotation.
8. Inspect all electrical connections. Be sure connections are clean and tight at the terminals.
9. Check unit controls. If Complete C or Deluxe D, verify field provided thermostat is available. If WSHP Open, verify proper sensor has been provided and a commissioning interface will be available.
10. 50PSH Only - Locate the hanging bracket kit located in the compressor compartment.
11. Remove the foam blower shipping support from underneath the blower section.
12. Remove any shipping brackets from the unit.

Step 3 — Locate Unit

Locate the unit in an indoor area that allows easy removal of the filter and access panels, and has enough room for service personnel to perform maintenance or repair. Provide sufficient room to make fluid, electrical, and duct connection(s). If the unit is located in a confined space such as a closet, provisions must be made for return air to freely enter the space.

Unit condensate drains are not internally trapped. Allow room below the unit base for horizontal models for an adequate condensate trap.

These units are not approved for outdoor installation; therefore, they must be installed inside the structure being conditioned. Do not locate units in areas that are subject to freezing. Units must be installed in conditioned space that is not subject to extremes of temperature or humidity to avoid cabinet sweating and/or equipment damage.

IMPORTANT: Care must be taken to prevent the introduction of dust, pain, debris, or chemicals into the unit, which can cause damage to the unit, delay start-up, and may impact unit longevity.

Do not use units for temporary heating, air conditioning or ventilation during construction or remodeling, especially when plastering, sanding or painting or when replacing carpet or flooring. Dust and debris can clog the coil and blower. Chemical vapors can lead to formicary corrosion and damage the coil. Ensure adequate ventilation and debris collection during construction or remodeling.

PROTECTION

Once the units are properly positioned on the jobsite, cover them with either a shipping carton, vinyl film, or an equivalent protective covering. Cap open ends of pipes stored on the jobsite. This precaution is especially important in areas where painting, plastering, or spraying of fireproof material, etc. is not yet complete. Foreign material that accumulates within the units can prevent proper start-up and require costly clean-up operations. Before installing any of the system components, be sure to examine each pipe, fitting, and valve, and remove any dirt or foreign material found in or on these components.

Step 4 — Mount the Unit

DUCT FLANGES

The unit heat pumps feature foldout return and supply air duct flanges. These fold-out flanges allow the heat pumps to more easily fit through doorways and other tight spaces, and also prevent damage in shipping and handling.

It is recommended that all fold-out flanges be folded out once the heat pump is installed to ensure that return and supply airflow is not obstructed. These flanges can be easily folded using standard or duckbill pliers. Once folded out these flanges can be used to support light ductwork loads.

VERTICAL UNITS (50PSV)

Vertical units should be mounted level on a vibration absorbing pad slightly larger than the unit base in order to minimize vibration transmission from the unit to the building structure. See Fig. 3. It is generally not necessary to anchor the unit unless required by local code.

All major service access for the vertical models is from the front side of the unit. When installing the unit in a confined space such as a closet, ensure that the service panel screws are accessible, that the filter can be replaced without damage and that water and electrical connections are accessible. For models with a unit-mounted disconnect switch, make sure the switch can be easily seen and operated.

To reduce sound transmission, units should be installed using flexible electrical conduit and hose kits. Care should be taken to ensure that no part of the unit cabinet is touching part of the building structure. For ducted return applications, a flexible duct connection should be used. Mount the unit on a vibration absorption pad slightly larger than the entire base to minimize vibration transmission. It is not necessary to mount the unit on the floor.

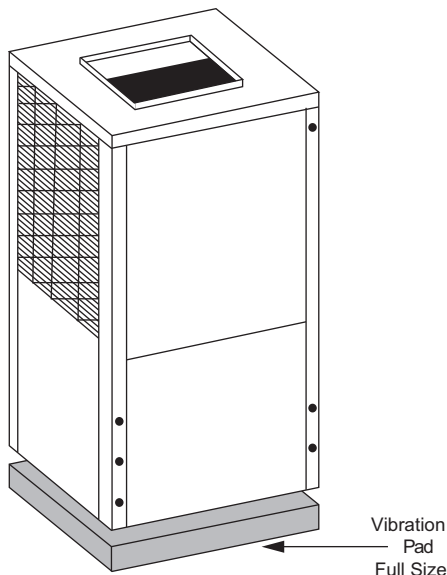

Fig. 3 — Vertical Unit on Vibration Pad

HORIZONTAL UNIT (50PSH)

While horizontal units may be installed on any level surface strong enough to hold their weight, they are typically suspended above a ceiling by threaded rods. All horizontal units come with a Hanging Bracket Kit to facilitate suspended unit mounting. Hanging brackets are installed as shown in Fig. 4.

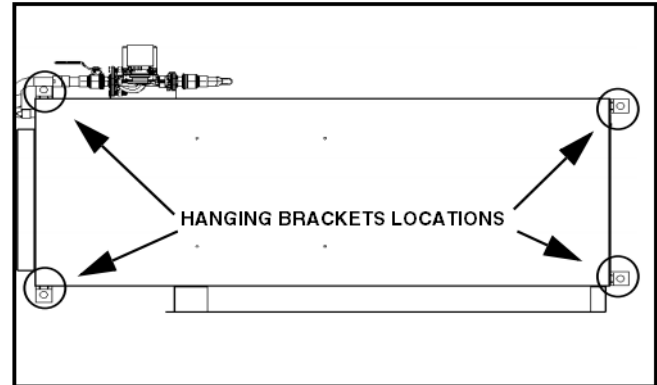

Fig. 4 — Hanging Bracket Locations

The hanging bracket kit includes the following:

- (5) Brackets
- (5) Rubber vibration isolators
- (8) Screws #10 x 1/2 in.
- (10) Bolts 1/4 – 28 x 1/2 in. hex bolt (not used on this model)

The following additional materials are needed and must be field-supplied:

- Threaded rod (3/8 in. maximum diameter)
- Hex nuts
- Washers (1-3/4 in. minimum O.D.)

Hanging Bracket Installation

1. Remove and discard factory-provided screws from location where hanging brackets will be installed. See Fig. 5.

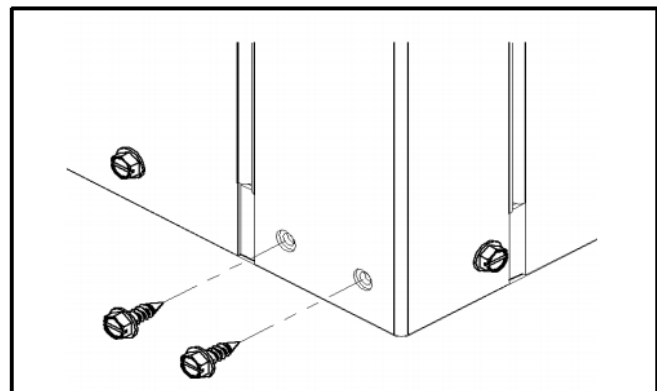

Fig. 5 — Removing Factory Screws

2. Mount 4 brackets to unit corner post using the bolts provided in the kit, as shown in Fig. 6. DO NOT re-use the screws removed from the unit during Step 1 to mount the hanging brackets on the unit.

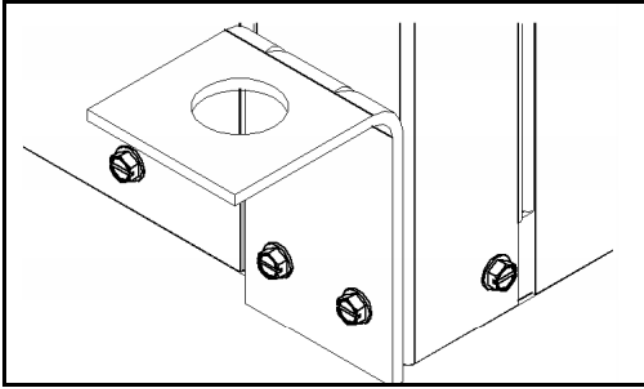

Fig. 6 — Mounting Brackets

3. Install rubber grommet on the bracket as shown in Fig. 7.
4. Hang the unit and assemble the field-provided threaded rod, nuts, and washers on the brackets as shown in Fig. 7.

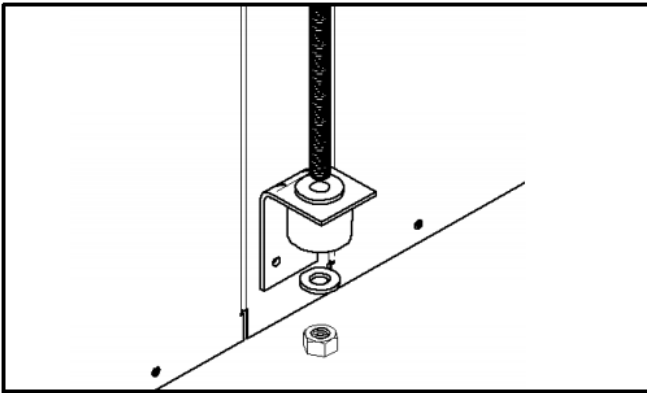

Fig. 7 — Hanging the Unit

IMPORTANT: Units larger than six tons include an integral angle iron frame with mounting holes present.

Horizontal units installed above the ceiling must conform to all local codes. An auxiliary drain pan if required by code, should be at least 4 in. larger than the bottom of the heat pump.

Plumbing connected to the heat pump must not come in direct contact with joists, trusses, walls, etc. Some applications require an attic floor installation of the horizontal unit. In this case the unit should be set in a full size secondary drain pan on top of a vibration absorbing mesh.

The secondary drain pan prevents possible condensate overflow or water leakage damage to the ceiling. The secondary drain pan is usually placed on a plywood base isolated from the ceiling joists by additional layers of vibration absorbing mesh. In both cases, a 3/4 in. drain connected to this secondary pan should be run to an eave at a location that will be noticeable.

⚠ CAUTION

If the unit is located in a crawl space, the bottom of the unit must be at least 4-in. above grade to prevent flooding of the electrical parts due to heavy rains.

Step 5 — Check Duct System

A supply air outlet collar and return air duct flange are provided on all units to facilitate duct connections. A flexible connector is recommended for supply and return air duct connections on metal duct systems. All metal ducting should be insulated with a minimum of 1 in. duct insulation to avoid heat loss or gain and prevent condensate forming during the cooling operation. Application of

the unit to uninsulated duct work is not recommended as the unit's performance will be adversely affected. Do not connect ducts directly to the blower outlet; factory supplied duct collars should be used for the connection to minimize unit vibration and noise transmission to the ductwork and ultimately into the conditioned space. The factory-provided air filter must be removed when using a filter back return air grill. The factory filter should be left in place on a free return system.

If the unit will be installed in a new installation which includes new duct work, the installation should be designed using current ASHRAE (American Society of Heating, Refrigerating, and Air-Conditioning Engineers) procedures for duct sizing. If the unit is to be connected to existing ductwork, a check should be made to assure that the duct system has the capacity to handle the air required for the unit application. If the duct system is too small, larger ductwork should be installed. Check for existing leaks and repair as necessary to ensure a tight air seal within the duct. The duct system and all diffusers should be sized to handle the designed air flow quietly. To maximize sound attenuation of the unit blower, the supply and return air plenums should be insulated. There should be no direct straight air path through the return air grille into the heat pump. The return air inlet to the heat pump must have at least one 90 degree turn away from the space return air grille. If air noise or excessive air flow are a problem, the blower speed can be changed to a lower speed to reduce air flow. (Refer to CFM motor speeds and settings in the blower performance tables starting on page 43.)

⚠ WARNING

Always disconnect power to the unit before changing motor speed to prevent damage to the motor, injury or death due to electrical shock.

HORIZONTAL SUPPLY AIR CONFIGURATION CONVERSION

The supply air location on horizontal units can be quickly field converted from end blow to straight through or vice-versa. To convert the supply air direction, follow the steps below:

1. If connected to power, shut off the unit and disconnect switch or circuit breaker.
2. Unscrew and remove the blower access panel.
3. Disconnect the wires from the unit electrical box to the blower motor. Note which speed taps are wired for units with PSC or constant torque motors.
4. Unscrew and carefully remove the blower panel with the blower and motor attached. Be careful not to damage the refrigerant coils or any other internal unit components.
5. Remove the blower support brackets from the bottom of the blower housing and relocate them to the top of the blower housing.
6. Turn the blower panel 180 degrees so that the blower support brackets are now at the bottom of the blower.
7. Insert the blower panel with the blower and motor into the desired location. Be careful not to damage the refrigerant coils or any other internal unit components. Screw the panel into place.
8. Replace the wires between the blower motor and electrical box. Make sure to connect wires to the proper speed taps.
9. Replace the blower access panel.
10. Reconnect power to the unit.

Step 6 — Install Condensate Drain

All units include a condensate drain pan under the evaporator coil. A drain line must be connected to the heat pump and pitched away from the unit a minimum of 1/8 in. per foot to allow the condensate to flow away from the unit.

This connection must be in conformance with local plumbing codes. A trap must be installed in the condensate line to ensure free condensate flow. (Heat Pumps are not internally trapped). A vertical air vent is sometimes required to avoid air pockets. See Fig. 8. The length of the trap depends on the amount of positive or negative pressure on the drain pan. A second trap must not be included.

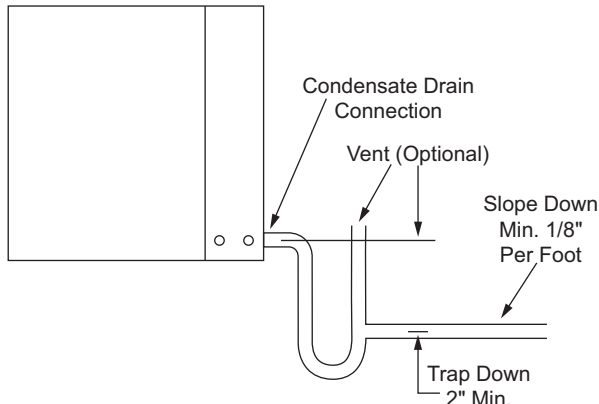

Fig. 8 — Condensate Trapping

The horizontal unit should be pitched approximately 1/4 in. towards the drain in both directions, to facilitate condensate removal. See Fig. 9.

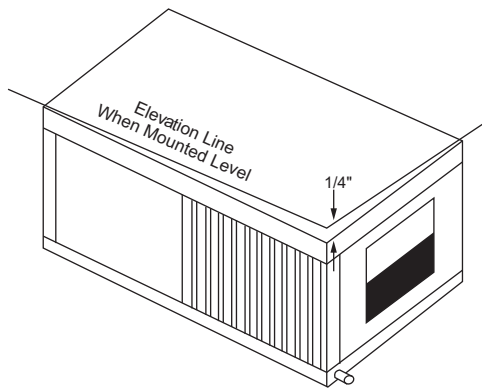

Fig. 9 — Sloped Horizontal Unit Installation

Step 7 — Pipe Connections

Depending on the application, there are 3 types of WSHP piping systems to choose from: water loop, ground-water and ground loop. Refer to Piping Section of Carrier System Design Manual for additional information.

All WSHP units use low temperature soldered female pipe thread fittings for water connections to prevent annealing and out-of-round leak problems which are typically associated with high temperature brazed connections. Refer to Table 1 for connection sizes. When making piping connections, consider the following:

- Use a backup wrench when making screw connections to unit to prevent internal damage to piping.
- Insulation may be required on piping to avoid condensation in the case where fluid in loop piping operates at temperatures below dew point of adjacent air.
- Piping systems that contain steel pipes or fittings may be subject to galvanic corrosion. Dielectric fittings may be used to isolate the steel parts of the system to avoid galvanic corrosion.

WATER LOOP APPLICATIONS

Water loop applications usually include a number of units plumbed to a common piping system. Maintenance to any of these units can introduce air into the piping system. Therefore, air elimination equipment comprises a major portion of the mechanical room plumbing.

The flow rate is usually set between 2.25 and 3.5 gpm per ton of cooling capacity. For proper maintenance and servicing, pressure-temperature (P/T) ports are necessary for temperature and flow verification.

Cooling tower/boiler systems typically utilize a common loop maintained at 50 to 100°F. The use of a closed circuit evaporative cooling tower with a secondary heat exchange between the tower and the water loop is recommended. If an open type cooling tower is used continuously, chemical treatment and filtering will be necessary.

In addition to complying with any applicable codes, consider the following for system piping:

- Piping systems using water temperatures below 50°F require 1/2-in. closed cell insulation on all piping surfaces to eliminate condensation.
- Avoid all plastic to metal threaded fittings due to the potential to leak. Use a flange fitted substitute.
- Teflon tape thread sealant is recommended to minimize internal fouling of the heat exchanger.
- Use backup wrench. Do not overtighten connections.
- Route piping to avoid service access areas to unit.
- Flush the piping system prior to operation to remove dirt and foreign materials from the system.

GROUND-WATER APPLICATIONS

Typical ground-water piping is shown in Fig. 10. In addition to complying with any applicable codes, consider the following for system piping:

- Install shut-off valves for servicing.
- Install pressure-temperature plugs to measure flow and temperature.
- Connect boiler drains and other valves using a "T" connector to allow acid flushing for the heat exchanger.
- Do not overtighten connections.
- Route piping to avoid service access areas to unit.
- Use PVC SCH80 or copper piping material.

NOTE: PVC SCH40 should *not* be used due to system high pressure and temperature extremes.

Water Supply and Quantity

Check water supply. Water supply should be plentiful and of good quality. See Table 2 for water quality guidelines.

IMPORTANT: Failure to comply with the above required water quality and quantity limitations and the closed-system application design requirements may cause damage to the tube-in-tube heat exchanger. This damage is not the responsibility of the manufacturer.

In all applications, the quality of the water circulated through the heat exchanger must be within the ranges listed in the Water Quality Guidelines. Consult a local water firm, independent testing facility, or local water authority for specific recommendations to maintain water quality within the published limits.

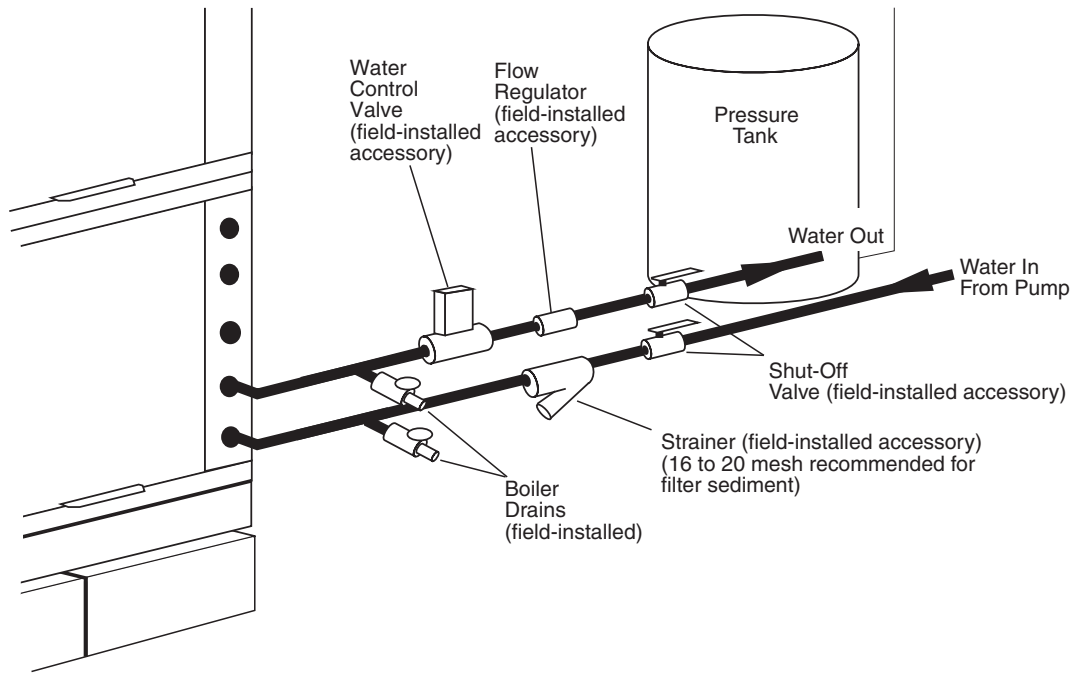

Fig. 10 — Typical Ground-Water Piping Installation

Table 2 — Water Quality Guidelines

CONDITION	HX MATERIAL ^a	CLOSED RECIRCULATING ^b	OPEN LOOP AND RECIRCULATING WELL ^c		
Scaling Potential — Primary Measurement					
Above the given limits, scaling is likely to occur. Scaling indexes should be calculated using the limits below.					
pH/Calcium Hardness Method	All	N/A	pH < 7.5 and Ca Hardness, <100 ppm		
Index Limits for Probable Scaling Situations (Operation outside these limits is not recommended.)					
Scaling indexes should be calculated at 150°F for direct use and HWG applications, and at 90°F for indirect HX use. A monitoring plan should be implemented.					
Ryznar Stability Index	All	N/A	6.0 to 7.5 If >7.5 minimize steel pipe use.		
Langelier Saturation Index	All	N/A	-0.5 to +0.5 If <-0.5 minimize steel pipe use. Based upon 150°F HWG and direct well, 85°F indirect well HX.		
Iron Fouling					
Iron Fe²⁺ (Ferrous) (Bacterial Iron Potential)	All	N/A	<0.2 ppm (Ferrous) If Fe ²⁺ (ferrous) >0.2 ppm with pH 6 to 8, O ₂ <5 ppm check for iron bacteria.		
Iron Fouling	All	N/A	<0.5 ppm of Oxygen Above this level deposition will occur.		
Corrosion Prevention^d					
pH	All	6 to 8.5 Monitor/treat as needed.	6 to 8.5 Minimize steel pipe below 7 and no open tanks with pH <8.		
Hydrogen Sulfide (H₂S)	All	N/A	<0.5 ppm At H ₂ S>0.2 ppm, avoid use of copper and cupronickel piping or HXs. Rotten egg smell appears at 0.5 ppm level. Copper alloy (bronze or brass) cast components are okay to <0.5 ppm.		
Ammonia Ion as Hydroxide, Chloride, Nitrate and Sulfate Compounds	All	N/A	<0.5 ppm		
Maximum Chloride Levels			Maximum allowable at maximum water temperature.		
			50°F (10°C)	75°F (24°C)	100°F (38°C)
	Copper	N/A	<20 ppm	NR	NR
	Cupronickel	N/A	<150 ppm	NR	NR
	304 SS	N/A	<400 ppm	<250 ppm	<150 ppm
	316 SS	N/A	<1000 ppm	<550 ppm	<375 ppm
	Titanium	N/A	>1000 ppm	>550 ppm	>375 ppm
Erosion and Clogging					
Particulate Size and Erosion	All	<10 ppm of particles and a maximum velocity of 6 fps. Filtered for maximum 800 micron size.	<10 ppm (<1 ppm "sandfree" for reinjection) of particles and a maximum velocity of 6 fps. Filtered for maximum 800 micron size. Any particulate that is not removed can potentially clog components.		
Brackish	All	N/A	Use cupronickel heat exchanger when concentrations of calcium or sodium chloride are greater than 125 ppm are present. (Seawater is approximately 25,000 ppm.)		

NOTE(S):

- Heat exchanger materials considered are copper, cupronickel, 304 SS (stainless steel), 316 SS, titanium.
- Closed recirculating system is identified by a closed pressurized piping system.
- Recirculating open wells should observe the open recirculating design considerations.
- If the concentration of these corrosives exceeds the maximum allowable level, then the potential for serious corrosion problems exists. Sulfides in the water quickly oxidize when exposed to air, requiring that no agitation occur as the sample is taken. Unless tested immediately at the site, the sample will require stabilization with a few drops of one Molar zinc acetate solution, allowing accurate sulfide determination up to 24 hours after sampling. A low pH and high alkalinity can cause system problems, even when both values are within ranges shown. The term pH refers to the acidity, basicity, or neutrality of the water supply. Below 7.0, the water is considered to be acidic. Above 7.0, water is considered to be basic. Neutral water registers a pH of 7.0. To convert ppm to grains per gallon, divide by 17. Hardness in mg/l is equivalent to ppm.

LEGEND

- HWG** — Hot Water Generator
HX — Heat Exchanger
N/A — Design Limits Not Applicable Considering Recirculating Potable Water
NR — Application Not Recommended
SS — Stainless Steel

GROUND-LOOP APPLICATIONS

Temperatures between 20 and 110°F and a cooling capacity of 2.25 to 3 gpm of flow per ton is recommended. In addition to complying with any applicable codes, consider the following for system piping:

- Limit piping materials to only polyethylene fusion in the buried sections of the loop.
- Do not use galvanized or steel fittings at any time due to corrosion.
- Avoid all plastic to metal threaded fittings due to the potential to leak. Use a flange fitted substitute.
- Do not overtighten connections.
- Route piping to avoid service access areas to unit.
- Use pressure-temperature (P/T) plugs to measure flow of pressure drop.

INSTALLATION OF SUPPLY AND RETURN HOSE KIT

Follow these piping guidelines.

1. Install a drain valve at the base of each supply and return riser to facilitate system flushing.
2. Install shutoff/balancing valves and unions at each unit to permit unit removal for servicing.
3. Place strainers at the inlet of each system circulating pump.
4. Select the proper hose length to allow slack between connection points. Hoses may vary in length by +2% to -4% under pressure.
5. Refer to Table 3. Do not exceed the minimum bend radius for the hose selected. Exceeding the minimum bend radius may cause the hose to collapse, which reduces water flow rate. Install an angle adapter to avoid sharp bends in the hose when the radius falls below the required minimum.

NOTE: Piping must comply with all applicable codes.

Table 3 — Metal Hose Minimum Bend Radii

HOSE DIAMETER (in.)	MINIMUM BEND RADII (in.)
1/2	2-1/2
3/4	4
1	5-1/2

Insulation is not required on loop water piping except where the piping runs through unheated areas or outside the building or when the loop water temperature is below the minimum expected dew point of the pipe ambient. Insulation is required if loop water temperature drops below the dew point.

IMPORTANT: Do not bend or kink supply lines or hoses.

Pipe joint compound is not necessary when Teflon¹ threaded tape is pre-applied to hose assemblies or when flared-end connections are used. If pipe joint compound is preferred, use compound only in small amounts on the male pipe threads of the fitting adapters. Prevent sealant from reaching the flared surfaces of the joint.

NOTE: When antifreeze is used in the loop, ensure that it is compatible with Teflon tape or pipe joint compound employed.

Maximum allowable torque for brass fittings is 30 ft-lb. If a torque wrench is not available, tighten finger-tight plus one quarter turn. Tighten steel fittings as necessary.

Optional pressure-rated hose assemblies designed specifically for use with Carrier units are available. Similar hoses can be obtained from alternate suppliers. Supply and return hoses are fitted with swivel-joint fittings at one end to prevent kinking during installation.

⚠ CAUTION

Backup wrench is required when tightening water connections to prevent water line damage. Failure to use a backup wrench could result in equipment damage.

Male adapters secure hose assemblies to the unit and risers. Install hose assemblies properly and check them regularly to avoid system failure and reduced service life. See Fig. 11.

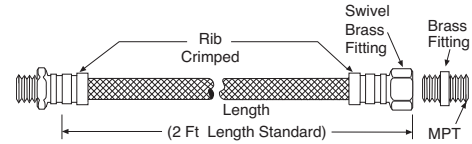

Fig. 11 — Supply/Return Hose Kit

AQUASTAT BULB INSTALLATION

Units with Complete C or Deluxe D controls and waterside economizer or units with Boilerless Heat Control (all Deluxe D) include an aquastat with remote sensing bulb that must be field installed on the incoming water piping. The remote sensing bulb must be installed on a straight section of uninsulated pipe that provides a good measurement of the entering water temperature. It is recommended to insulate the sensing bulb after installation for better water temperature sensing.

INSTALLATION OF HOT WATER GENERATOR OPTION

The hot water generator (HWG) is a factory-installed option capable of providing hot water in the range of 110 to 140°F as a supplemental domestic hot water source. The HWG is a desuperheater that uses recovered heat from the hot discharge gas leaving the compressor. Included with the HWG is a vented, double wall coil, circulating pump, high water temperature limit switch (set at 140°F), discharge gas temperature limit switch, and an ON/OFF switch with built-in circuit breaker. The generator operates independently and is not factory wired to the unit controller.

NOTE: The HWG will reduce the amount of heat available to the space and it is recommended to deactivate the HWG in heating mode via the ON/OFF switch.

Water Tank Preparation

1. Turn off electrical or fuel supply to the water heater.
2. Attach garden hose to water tank drain connection and run other end of hose outdoors or to an open drain.
3. Close cold water inlet valve to water heater tank.
4. Drain tank by opening drain valve on the bottom of the tank, then open pressure relief valve or hot water faucet.
5. Once drained the tank should be flushed with cold water until the water leaving the drain hose is clear and free of sediment.
6. Close all valves and remove the drain hose.
7. Install HWG water piping.

All hot water piping should be a minimum of 3/8 in. OD copper tube to a maximum distance of fifteen feet. For distances beyond fifteen feet but not exceeding sixty feet use 1/2 in. copper tube. Separately insulate all exposed surface of both connecting water lines with 3/8 in. wall closed cell insulation. Install isolation valves on supply and return to the hot water generator. See Fig. 12.

NOTE: Diagram is for illustration purposes only. Ensure access to heat pump is not restricted. All plumbing and piping connections must comply with local plumbing codes.

1. Teflon is a registered trademarks of DuPont.

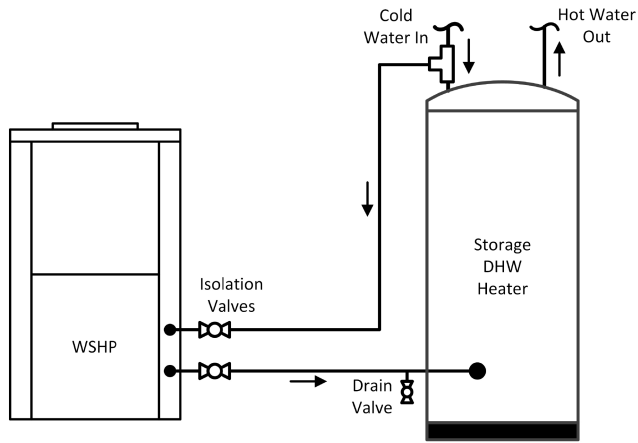

Fig. 12 — Typical Hot Water Generator Installation

Water Tank Refill

1. Open the cold water supply to the tank.
2. Open a hot water faucet to vent air from the system until water flows from the faucet, then close.
3. Depress the hot water tank pressure relief valve handle to ensure there is no air remaining in the tank.
4. Carefully inspect all plumbing for water leaks. Correct as required.
5. Purge all air from HWG by depressing the Schrader valve on the HR unit. Allow all air to bleed out until water appears at the valve.
6. Before restoring the power or fuel supply to the water heater, adjust the temperature setting on the tank thermostat(s) to ensure maximum utilization of heat available from the refrigeration system and to conserve the most energy. On tanks with thermostats and both upper and lower elements, the lower element should be turned down to 100°F, while the upper element should be adjusted to 120°F. Depending upon the specific needs of the customer, you may need to adjust the upper element differently. On tanks with a single thermostat, lower the thermostat setting to 120°F or the “LOW” position. After thermostat adjustments are completed, replace access cover and restore electrical or fuel supply to water heater.

Initial Start-Up

1. Turn on the heat pump. The circulating pump should not run if the compressor is not running.
2. Turn HWG switch to the “ON” position. The pump will operate if entering water temperature to HWG is below 120°F.
3. Ensure the temperature difference between the water entering and leaving the heat recovery is 5 to 15°F.
4. Allow the unit to operate for 20 to 30 minutes to ensure it is functioning properly. The pump should shut off when the water temperature entering the generator reaches 120°F.

Step 8 — Wire Field Power Supply

See Fig. 13-32 for typical wiring diagrams. See Tables 4-5 for additional electrical data. See Tables 6-8 for data plate specifics. Please refer to the unit wiring diagram attached to the control panel for field installation.

⚠ WARNING

To avoid possible injury or death due to electrical shock, open the power supply disconnect switch and secure it in an open position during installation.

⚠ CAUTION

Operating the unit with improper line voltage or with excessive phase imbalance is hazardous to the unit and constitutes abuse and is not covered under warranty.

HIGH VOLTAGE

All field-installed wiring must comply with the National Electric Code as well as all applicable local codes. Refer to the unit electrical data on the unit nameplate for wire and branch circuit protection sizing. Supply power voltage and phasing should match the required voltage and phasing shown on the unit nameplate. Operating the unit below the minimum voltage, above the maximum voltage or with incorrect phasing can result in poor system performance or damage to the heat pump. All field wiring should be installed by qualified and trained personnel. Refer to the unit wiring diagram for field connection requirements.

Power wiring to the heat pump should be enclosed in flexible conduit to minimize the transmission of vibration from the unit cabinet to the building. For heat pumps with unit mounted disconnect switches, field power should be connected to the marked terminals on the disconnect switch. For heat pumps without unit-mounted disconnect switches (except units with dual power supply), power is connected to the line (L) side of the compressor contactor and the ground lug in the unit electrical box.

Transformer Settings for 208/230-v Units

As factory built, all 208/230-v units are wired for 230-v operation. For jobsites with a 208-v power supply, the primary leads on the unit transformer will need to be changed from 230-v to 208-v. Refer to the unit wiring diagram for details.

Integrated Electric Heat Option

Factory-installed internal electric heater packages are available for select units. Two power supplies are required when heater packages are utilized. The power supply for the heater package (located in the electric heater package control box) provides power for the heater elements, the blower motor, and the control circuit for the unit. The power supply for the unit provides power for the compressor. This allows the electric heaters to continue to operate along with the blower motor in the case of unit compressor and/or compressor power supply failure.

UPM STATUS LED - BLINK CODES	
1	HIGH PRESSURE FAULT
2	LOW PRESSURE FAULT
3	CONDENSER FREEZE CONDITION
4	CONDENSATE OVERFLOW FAULT
5	BROWN OUT FAULT
6	EVAPORATOR FREEZE CONDITION

FACTORY WIRE —————
FIELD WIRE - - - - -

STANDARD COMPONENTS LEGEND:
 BC - BLOWER MOTOR CAPACITOR
 BM - BLOWER MOTOR
 BR - BLOWER RELAY
 CAP - COMPRESSOR CAPACITOR
 CBR - 24V CIRCUIT BREAKER
 CC - COMPRESSOR CONTACTOR
 COMP - COMPRESSOR
 CS - CONDENSATE SENSOR (IN DRAIN PAN)
 FS - FREEZE SENSOR
 HPS - HIGH PRESSURE SWITCH
 LPS - LOW PRESSURE SWITCH
 RV - REVERSING VALVE (HEAT PUMPS)

OPTIONAL COMPONENTS LEGEND:
 [] DS - DISCONNECT SWITCH
 [] HSL - HIGH TEMPERATURE SUCTION LIMIT (WITH HOT GAS BYPASS ONLY)
 [] HRP - HEAT RECOVERY PACKAGE:
 HRP- HEAT RECOVERY PUMP
 LGL - LOW GAS TEMPERATURE LIMIT
 HWL - HOT WATER LIMIT
 [] SWT - ON/OFF SWITCH OVERLOAD PROTECTION
 [] LWV - LEAVING WATER VALVE
 [] VES - VALVE END SWITCH

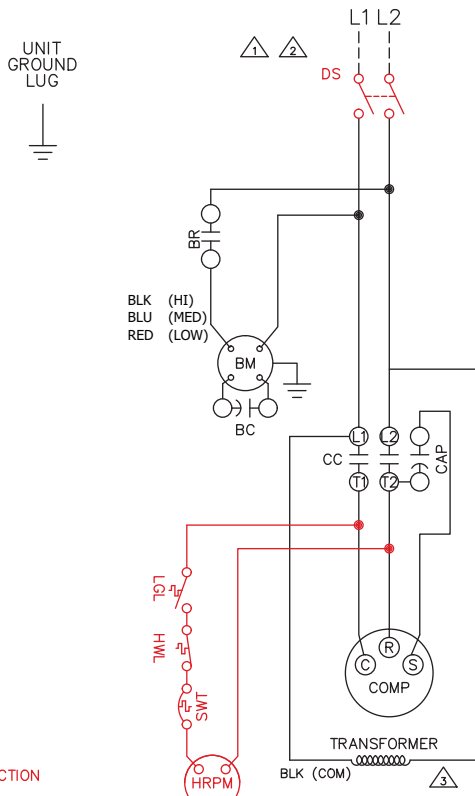

USE CLASS II FIELD WIRING

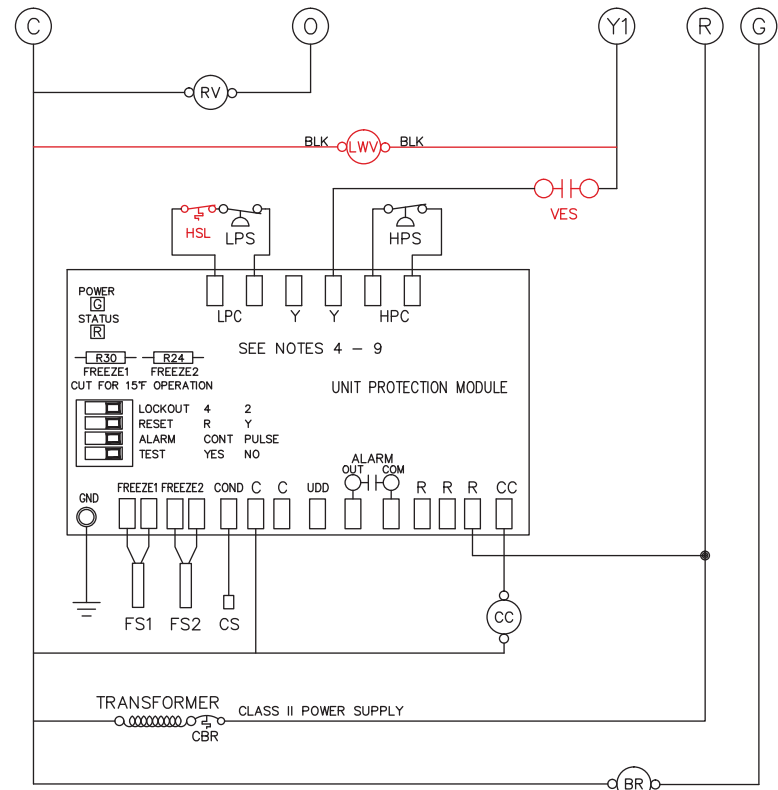

NOTES:

- SEE UNIT NAMEPLATE FOR ELECTRICAL RATING.
- ALL FIELD WIRING MUST BE IN ACCORDANCE WITH NEC-NFPA #70, COPPER CONDUCTORS ONLY.
- 208/230V UNITS ARE FACTORY WIRED FOR 230V OPERATION. FOR 208V OPERATION, REMOVE LEAD FROM 240 TERMINAL AND CONNECT IT TO 208. CAP ALL UNUSED TERMINALS.
- UPM-1 INCLUDES BUILT IN: 270-300 SECOND RANDOM START
300 SECOND DELAY ON BREAK
120 SECOND LOW PRESSURE BYPASS
- "TEST" DIP SWITCH REDUCES DELAYS TO 10 SEC WHEN SET TO YES. MUST BE SET TO "NO" FOR NORMAL OPERATION.
- "FREEZE SENSOR" ON CONDENSER WILL OPERATE AT 26 F BY DEFAULT, IF 15 F OPERATION IS REQUIRED JUMPER R30 MUST BE CUT. IF FREEZE SENSOR IS NOT INSTALLED A JUMPER SHALL BE INSTALLED BETWEEN THE FREEZE1 OR FREEZE2 SENSOR TERMINALS.
- "ALARM OUTPUT" DIP SWITCH MUST BE SET TO "PULSE" IF BLINKING T-STAT SERVICE LIGHT IS DESIRED.
- DEFAULT SETTINGS FOR UPM BOARD FROM FACTORY SHOWN.
- ALARM OUTPUT IS NORMALLY OPEN (NO) DRY CONTACT. IF 24 VAC IS NEEDED, CONNECT R TO ALR-COM TERMINAL. 24 VAC WILL BE SENSED ON THE ALR-OUT WHEN THE UNIT IS IN ALARM CONDITION. OUTPUT WILL BE PULSED IF PULSE IS SELECTED.
- FACTORY-MOUNTED LOOP PUMP OR TWO-WAY WATER VALVE. BOTH DEVICES WILL NOT BE PRESENT IN THE SAME UNIT.

1 STAGE - 1 PHASE - PSC MOTOR 1/2 THROUGH 1 TONS CAPACITY UPM I - C			
PART No.	8 733 810 189		
DWG No.	DRAWN BY:	DATE	REV
50PS111001	MLM	06/23/2016	3
E-MAIL:			

Fig. 13 — PSC Motor Single Phase/Single Stage Complete C Control

UPM STATUS LED - BLINK CODES	
1	HIGH PRESSURE FAULT
2	LOW PRESSURE FAULT
3	CONDENSER FREEZE CONDITION
4	CONDENSATE OVERFLOW FAULT
5	BROWN OUT FAULT
6	EVAPORATOR FREEZE CONDITION

FACTORY WIRE ———
FIELD WIRE - - - - -

STANDARD COMPONENTS LEGEND:

- AUX — AUXILIARY RELAY (FOR LOOP PUMP, ETC)
- BCA — BOILERLESS CONTROL AQUASTAT
- BC — BLOWER MOTOR CAPACITOR
- BM — BLOWER MOTOR
- BR — BLOWER RELAY
- CAP — COMPRESSOR CAPACITOR
- CBR — 24V CIRCUIT BREAKER
- CC — COMPRESSOR CONTACTOR
- COMP — COMPRESSOR
- CS — CONDENSATE SENSOR (IN DRAIN PAN)
- EMS — ENERGY MGMT SYSTEM RELAY
- FS — FREEZE SENSOR
- HCR — HEATING/COOLING RELAY
- HPS — HIGH PRESSURE SWITCH
- LED — UNIT STATUS LED
- LP — LOOP PUMP (FIELD INSTALLED)
- LPS — LOW PRESSURE SWITCH
- RV — REVERSING VALVE (HEAT PUMPS)

OPTIONAL COMPONENTS LEGEND:

- [] DS — DISCONNECT SWITCH
- [] HRP — HEAT RECOVERY PACKAGE
- [] HRPMP — HEAT RECOVERY PUMP
- [] LGL — LOW GAS TEMPERATURE LIMIT
- [] HWL — HOT WATER LIMIT
- [] SWT — ON/OFF SWITCH OVERLOAD PROTECTION
- [] HSL — HIGH TEMPERATURE SUCTION LIMIT (WITH HOT GAS BYPASS ONLY)
- [] LWV — LEAVING WATER VALVE
- [] YES — VALVE END SWITCH

NOTES:

1. SEE UNIT NAMEPLATE FOR ELECTRICAL RATING.
2. ALL FIELD WIRING MUST BE IN ACCORDANCE WITH NEC-NFPA #70, COPPER CONDUCTORS ONLY.
3. 208/230V UNITS ARE FACTORY WIRED FOR 230V OPERATION. FOR 208V OPERATION, REMOVE ORG LEAD AND REPLACE WITH RED LEAD. CAP ALL UNUSED LEADS.
4. FOR ALTERNATIVE EMS COIL VOLTAGES CONSULT FACTORY.
5. UPM-1 INCLUDES BUILT IN: 270-300 SECOND RANDOM START
300 SECOND DELAY ON BREAK
120 SECOND LOW PRESSURE BYPASS
6. "TEST" DIP SWITCH REDUCES DELAYS TO 10 SEC WHEN SET TO YES. MUST BE SET TO "NO" FOR NORMAL OPERATION.
7. "FREEZE SENSOR" ON CONDENSER WILL OPERATE AT 26 F BY DEFAULT, IF 15 F OPERATION IS REQUIRED JUMPER R30 MUST BE CUT. IF FREEZE SENSOR IS NOT INSTALLED A JUMPER SHALL BE INSTALLED BETWEEN THE FREEZE1 OR FREEZE2 SENSOR TERMINALS.
8. "ALARM OUTPUT" DIP SWITCH MUST BE SET TO "PULSE" IF BLINKING T-STAT SERVICE LIGHT IS DESIRED.
9. DEFAULT SETTINGS FOR UPM BOARD FROM FACTORY SHOWN.
10. ALARM OUTPUT IS NORMALLY OPEN (NO) DRY CONTACT. IF 24 VAC IS NEEDED, CONNECT R TO ALR-COM TERMINAL. 24 VAC WILL BE SENSED ON THE ALR-OUT WHEN THE UNIT IS IN ALARM CONDITION. OUTPUT WILL BE PULSED IF PULSE IS SELECTED.
11. FACTORY-MOUNTED LOOP PUMP OR TWO-WAY WATER VALVE. BOTH DEVICES WILL NOT BE PRESENT IN THE SAME UNIT.
12. BCA CONTACTS R-Y OPEN ON DROP IN WATER TEMPERATURE AND R-B CLOSE.

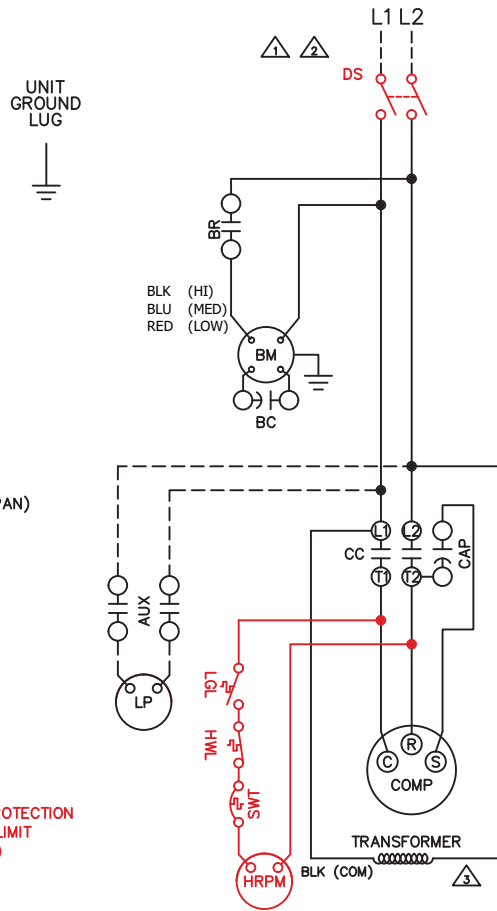

USE CLASS II FIELD WIRING

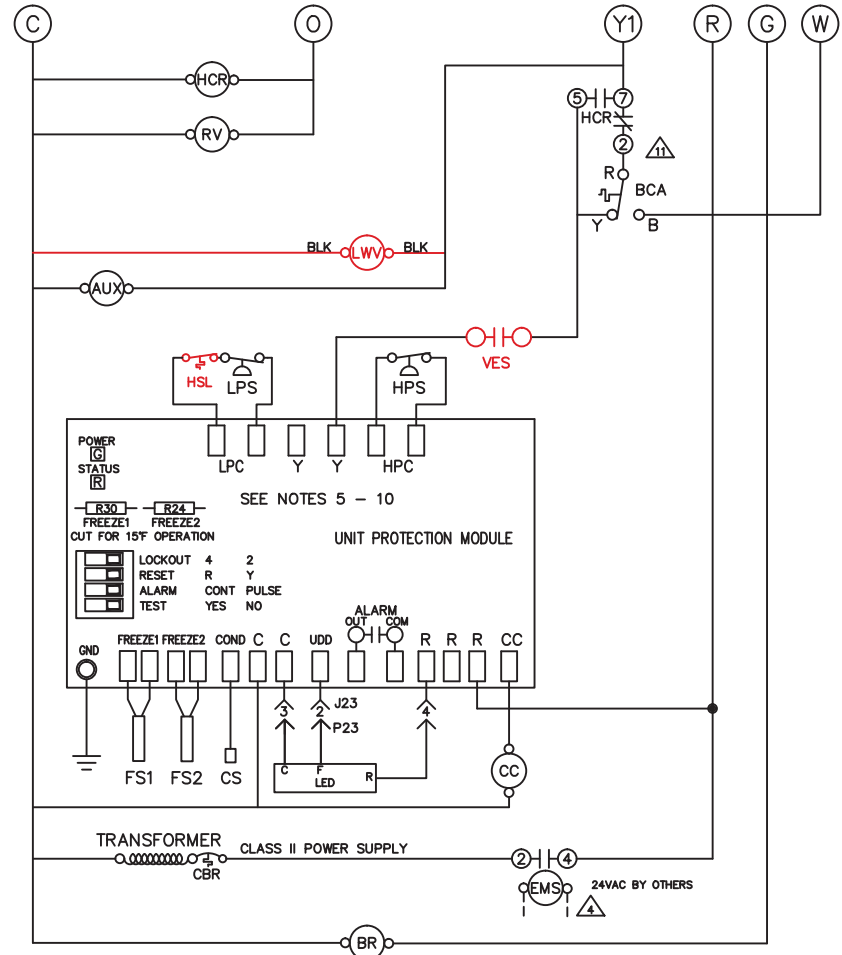

1 STAGE — 1 PHASE — PSC MOTOR			
1/2 THROUGH 1 TONS CAPACITY			
UPM I - D			
PART No.	8 733 810 288		
DWG No.	DRAWN BY:	DATE	REV
50PS111010	MLM	06/23/2016	5
E-MAIL:			

Fig. 14 — PSC Motor, Single Phase/Single Stage, Deluxe D Control

UPM STATUS LED - BLINK CODES	
1	HIGH PRESSURE FAULT
2	LOW PRESSURE FAULT
3	CONDENSER FREEZE CONDITION
4	CONDENSATE OVERFLOW FAULT
5	BROWNOUT FAULT
6	EVAPORATOR FREEZE CONDITION

FACTORY WIRE ———
FIELD WIRE - - - - -

STANDARD COMPONENTS LEGEND:
 AUX — AUXILIARY RELAY
 (FOR LOP PUMP, ETC)
 BM — BLOWER MOTOR
 CBR — 24V CIRCUIT BREAKER
 CAP — COMPRESSOR CAPACITOR
 CC — COMPRESSOR CONTACTOR
 CS — CONDENSATE SENSOR
 (IN DRAIN PAN)
 FS — FREEZE SENSOR
 HPS — HIGH PRESSURE SWITCH
 LED — UNIT STATUS LED
 LPS — LOW PRESSURE SWITCH
 RV — REVERSE VALVE(HEAT PUMPS)

OPTIONAL COMPONENTS LEGEND:
 [] HGV — HOT GAS VALVE SOLENOID
 (USE WITH WSHP ONLY)
 [] DS — DISCONNECT SWITCH
 [] LWV — LEAVING WATER VALVE
 [] VES — VALVE END SWITCH
 [] MVR — MOTORIZED VALVE RELAY
 [] MBV — MOTORIZED BALL VALVE
 [] F/A — FIRE ALARM RELAY CONTACTS

- NOTES:
- SEE UNIT NAME PLATE FOR ELECTRICAL RATING.
 - ALL FIELD WIRING MUST BE IN ACCORDANCE WITH N.E.C.—N.F.P.A. #70, COPPER CONDUCTORS ONLY — CONDUCTEURS EN CUIVRE SEULEMENT.
 - 208/230V UNITS ARE FACTORY WIRED FOR 230V OPERATION. FOR 208V OPERATION, REMOVE LEAD FROM 240 TERMINAL AND CONNECT IT TO 208. CAP ALL UNUSED TERMINALS.
 - FOR ALTERNATE EMS COIL VOLTAGES CONSULT FACTORY
 - UPM-I INCLUDES BUILT IN: 270-300 SECOND RANDOM START
300 SECOND DELAY ON BREAK
120 SECOND LOW PRESSURE BYPASS
 - "TEST" DIP SWITCH REDUCES DELAYS TO 10 SEC WHEN SET TO YES. MUST BE SET TO "NO" FOR NORMAL OPERATION.
 - "FREEZE SENSOR" ON CONDENSER WILL OPERATE AT 26°F BY DEFAULT, IF 15°F OPERATION IS REQUIRED JUMPER R30 MUST BE CUT IF FREEZE SENSOR IS NOT INSTALLED A JUMPER SHALL BE INSTALLED BETWEEN THE FREEZE1 OR FREEZE2 SENSOR TERMINALS.
 - "ALARM OUTPUT" DIP SWITCH MUST BE SET TO "PULSE" IF BLINKING T-STAT SERVICE LIGHT IS DESIRED.
 - DEFAULT SETTINGS FOR UPM BOARD FROM FACTORY SHOWN. ALSO SEE INSTALLATION MANUAL.
 - ALARM OUTPUT IS NORMALLY OPEN (NO) DRY CONTACT. IF 24 VAC IS NEEDED, CONNECT R TO ALR-COM TERMINAL, 24VAC WILL BE SENSED ON THE ALR-OUT WHEN THE UNIT IS IN ALARM CONDITION. OUTPUT WILL BE PULSED IF PULSE IS SELECTED.
 - FACTORY MOUNTED LOOP PUMP OR TWO WAY WATER VALVE. BOTH DEVICES WILL NOT BE PRESENT IN THE SAME UNIT.

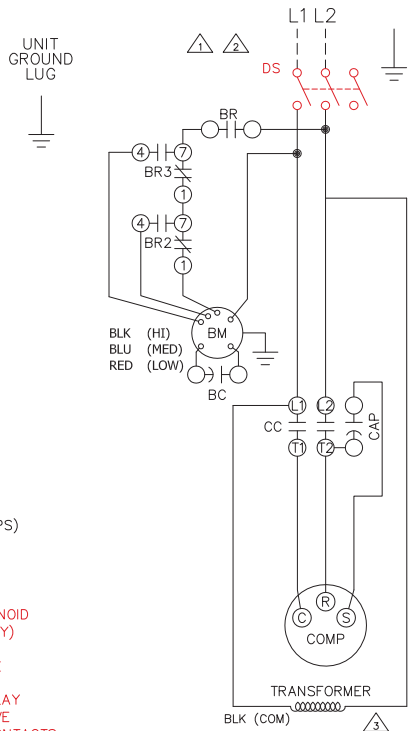

USE CLASS II FIELD WIRING — TO WSHP OPEN INTERFACE J1 AND J11

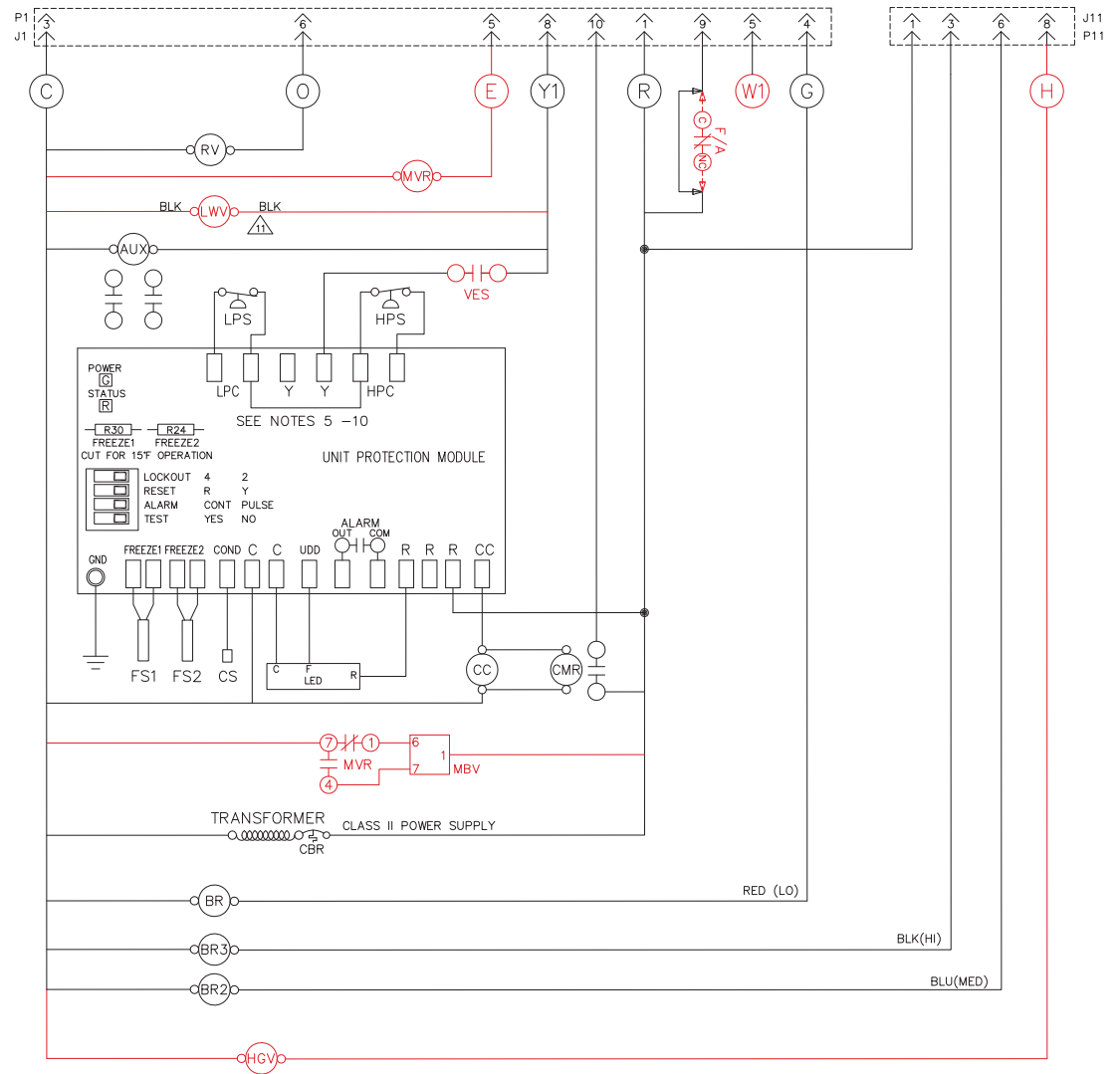

Fig. 15 — PSC Motor, Single Phase/Single Stage, WSHP Open Control

UPM STATUS LED - BLINK CODES	
1	HIGH PRESSURE FAULT
2	LOW PRESSURE FAULT
3	CONDENSER FREEZE CONDITION
4	CONDENSATE OVERFLOW FAULT
5	BROWN OUT FAULT
6	EVAPORATOR FREEZE CONDITION

FACTORY WIRE —————
FIELD WIRE - - - - -

STANDARD COMPONENTS LEGEND:

- BM - BLOWER MOTOR
- CAP - COMPRESSOR CAPACITOR
- CBR - 24V CIRCUIT BREAKER
- CC - COMPRESSOR CONTACTOR
- COMP - COMPRESSOR
- CS - CONDENSATE SENSOR (IN DRAIN PAN)
- FS - FREEZE SENSOR
- HPS - HIGH PRESSURE SWITCH
- LPS - LOW PRESSURE SWITCH
- RV - REVERSING VALVE (HEAT PUMPS)

OPTIONAL COMPONENTS LEGEND:

- [] DS - DISCONNECT SWITCH
- [] HSL - HIGH TEMPERATURE SUCTION LIMIT (WITH HOT GAS BYPASS ONLY)
- [] HRP - HEAT RECOVERY PACKAGE:
HRPM - HEAT RECOVERY PUMP
- [] LGL - LOW GAS TEMPERATURE LIMIT
- [] HWL - HOT WATER LIMIT
- [] SWT - ON/OFF SWITCH OVERLOAD PROTECTION
- [] LWV - LEAVING WATER VALVE
- [] VES - VALVE END SWITCH

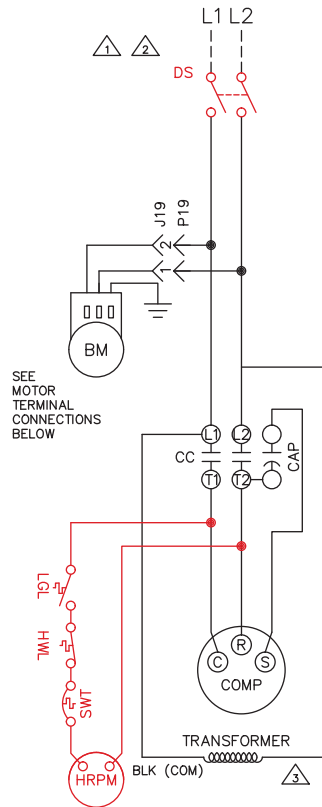

USE CLASS II FIELD WIRING

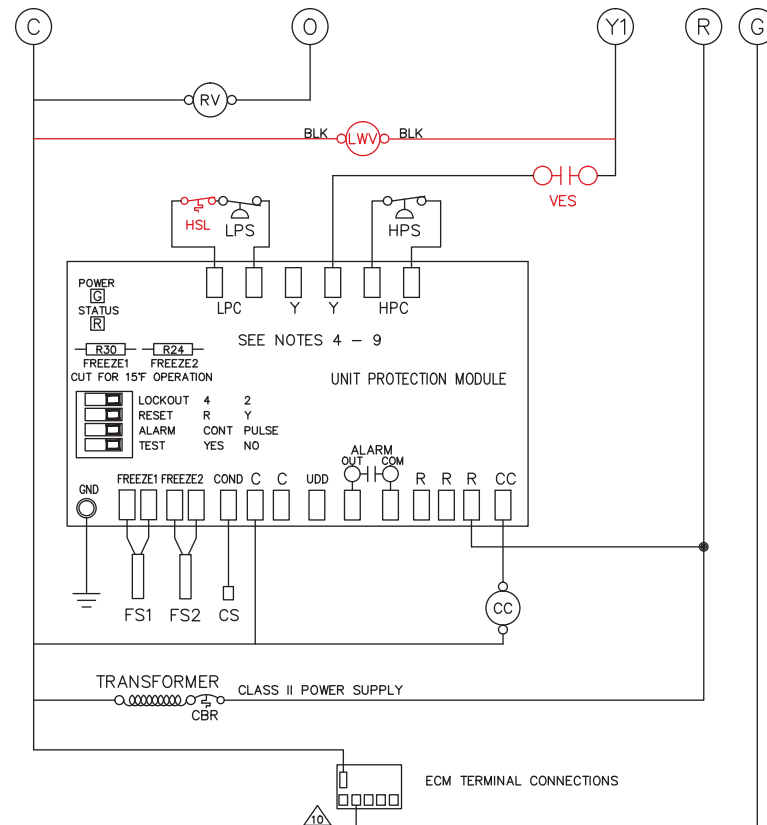

NOTES:

- SEE UNIT NAMEPLATE FOR ELECTRICAL RATING.
- ALL FIELD WIRING MUST BE IN ACCORDANCE WITH NEC-NFPA #70, COPPER CONDUCTORS ONLY.
- 208/230V UNITS ARE FACTORY WIRED FOR 230V OPERATION. FOR 208V OPERATION, REMOVE LEAD FROM 240 TERMINAL AND CONNECT IT TO 208. CAP ALL UNUSED TERMINALS.
- UPM-1 INCLUDES BUILT IN: 270-300 SECOND RANDOM START
300 SECOND DELAY ON BREAK
120 SECOND LOW PRESSURE BYPASS
- "TEST" DIP SWITCH REDUCES DELAYS TO 10 SEC WHEN SET TO YES. MUST BE SET TO "NO" FOR NORMAL OPERATION.
- "FREEZE SENSOR" ON CONDENSER WILL OPERATE AT 26 F BY DEFAULT, IF 15 F OPERATION IS REQUIRED JUMPER R30 MUST BE CUT. IF FREEZE SENSOR IS NOT INSTALLED A JUMPER SHALL BE INSTALLED BETWEEN THE FREEZE1 OR FREEZE2 SENSOR TERMINALS.
- "ALARM OUTPUT" DIP SWITCH MUST BE SET TO "PULSE" IF BLINKING T-STAT SERVICE LIGHT IS DESIRED.
- DEFAULT SETTINGS FOR UPM BOARD FROM FACTORY SHOWN.
- ALARM OUTPUT IS NORMALLY OPEN (NO) DRY CONTACT. IF 24 VAC IS NEEDED, CONNECT R TO ALR-COM TERMINAL. 24 VAC WILL BE SENSED ON THE ALR-OUT WHEN THE UNIT IS IN ALARM CONDITION. OUTPUT WILL BE PULSED IF PULSE IS SELECTED.
- FACTORY-MOUNTED LOOP PUMP OR TWO-WAY WATER VALVE. BOTH DEVICES WILL NOT BE PRESENT IN THE SAME UNIT.

HIGH VOLTAGE MOTOR CONNECTIONS

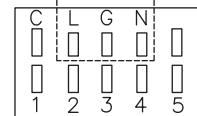

X13 TERMINAL CONNECTIONS

- N - L2
- G - GROUND
- L - L1
- C - 24V COMMON
- 1-5 - SPEED TAPS

1 STAGE - 1 PHASE - X13 MOTOR			
1 1/4 THROUGH 6 TONS CAPACITY			
UPM I - C			
PART No.	8 733 810 188		
DWG No.	50PS111000	DRAWN BY:	MLM
		DATE	06/23/2016
		REV	4
E-MAIL:			

Fig. 16 — Constant Torque Motor, Single Phase/Single Stage, Complete C Control

UPM STATUS LED - BLINK CODES	
1	HIGH PRESSURE FAULT
2	LOW PRESSURE FAULT
3	CONDENSER FREEZE CONDITION
4	CONDENSATE OVERFLOW FAULT
5	BROWN OUT FAULT
6	EVAPORATOR FREEZE CONDITION

FACTORY WIRE —————
FIELD WIRE - - - - -

STANDARD COMPONENTS LEGEND:

- AUX - AUXILIARY RELAY (FOR LOOP PUMP, ETC)
- BCA - BOILERLESS CONTROL AQUASTAT
- BM - BLOWER MOTOR
- CAP - COMPRESSOR CAPACITOR
- CBR - 24V CIRCUIT BREAKER
- CC - COMPRESSOR CONTACTOR
- COMP - COMPRESSOR
- CS - CONDENSATE SENSOR (IN DRAIN PAN)
- EMS - ENERGY MGMT SYSTEM RELAY
- FS - FREEZE SENSOR
- HCR - HEATING/COOLING RELAY
- HPS - HIGH PRESSURE SWITCH
- LED - UNIT STATUS LED
- LPS - LOW PRESSURE SWITCH
- LP - LOOP PUMP (FIELD INSTALLED)
- RV - REVERSING VALVE (HEAT PUMPS)

OPTIONAL COMPONENTS LEGEND:

- [] DS - DISCONNECT SWITCH
- [] HRP - HEAT RECOVERY PACKAGE:
- [] HRP - HEAT RECOVERY PUMP
- [] LGL - LOW GAS TEMPERATURE LIMIT
- [] HWL - HOT WATER LIMIT
- [] SWT - ON/OFF SWITCH OVERLOAD PROTECTION
- [] HSL - HIGH TEMPERATURE SUCTION LIMIT (WITH HOT GAS BYPASS ONLY)
- [] LWV - LEAVING WATER VALVE
- [] VES - VALVE END SWITCH

NOTES:

1. SEE UNIT NAMEPLATE FOR ELECTRICAL RATING.
2. ALL FIELD WIRING MUST BE IN ACCORDANCE WITH NEC-NFPA #70, COPPER CONDUCTORS ONLY.
3. 208/230V UNITS ARE FACTORY WIRED FOR 230V OPERATION. FOR 208V OPERATION, REMOVE ORG LEAD AND REPLACE WITH RED LEAD. CAP ALL UNUSED LEADS.
4. FOR ALTERNATIVE EMS COIL VOLTAGES CONSULT FACTORY.
5. UPM-1 INCLUDES BUILT IN: 270-300 SECOND RANDOM START
300 SECOND DELAY ON BREAK
120 SECOND LOW PRESSURE BYPASS
6. "TEST" DIP SWITCH REDUCES DELAYS TO 10 SEC WHEN SET TO YES. MUST BE SET TO "NO" FOR NORMAL OPERATION.
7. "FREEZE SENSOR" ON CONDENSER WILL OPERATE AT 26 F BY DEFAULT, IF 15 F OPERATION IS REQUIRED JUMPER R30 MUST BE CUT. IF FREEZE SENSOR IS NOT INSTALLED A JUMPER SHALL BE INSTALLED BETWEEN THE FREEZE1 OR FREEZE2 SENSOR TERMINALS.
8. "ALARM OUTPUT" DIP SWITCH MUST BE SET TO "PULSE" IF BLINKING T-STAT SERVICE LIGHT IS DESIRED.
9. DEFAULT SETTINGS FOR UPM BOARD FROM FACTORY SHOWN.
10. ALARM OUTPUT IS NORMALLY OPEN (NO) DRY CONTACT. IF 24 VAC IS NEEDED, CONNECT R TO ALR-COM TERMINAL. 24 VAC WILL BE SENSED ON THE ALR-OUT WHEN THE UNIT IS IN ALARM CONDITION. OUTPUT WILL BE PULSED IF PULSE IS SELECTED.
11. FACTORY-MOUNTED LOOP PUMP OR TWO-WAY WATER VALVE. BOTH DEVICES WILL NOT BE PRESENT IN THE SAME UNIT.
12. BCA CONTACTS R-Y OPEN ON DROP IN WATER TEMPERATURE AND R-B CLOSE.

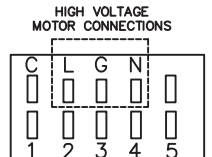
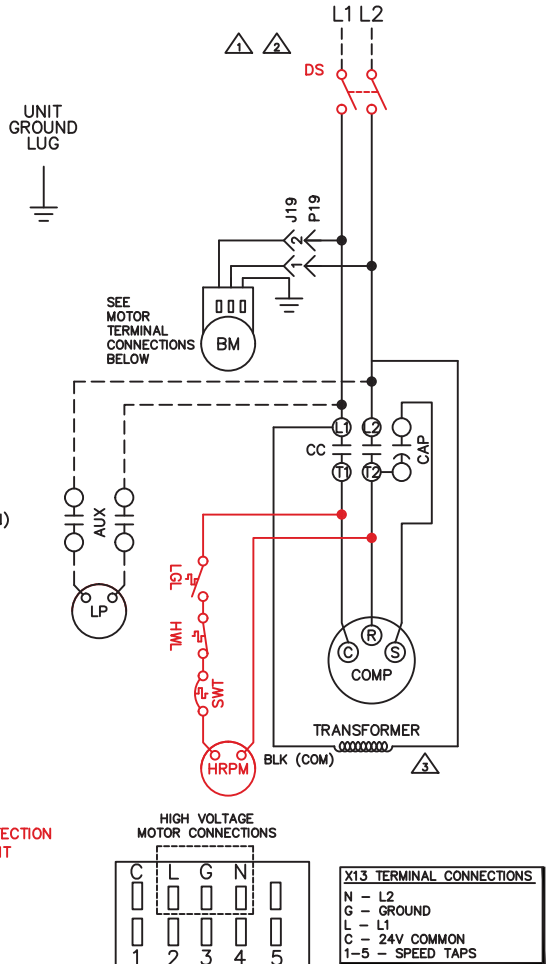

X13 TERMINAL CONNECTIONS	
N	- L2
G	- GROUND
L	- L1
C	- 24V COMMON
1-5	- SPEED TAPS

USE CLASS II FIELD WIRING

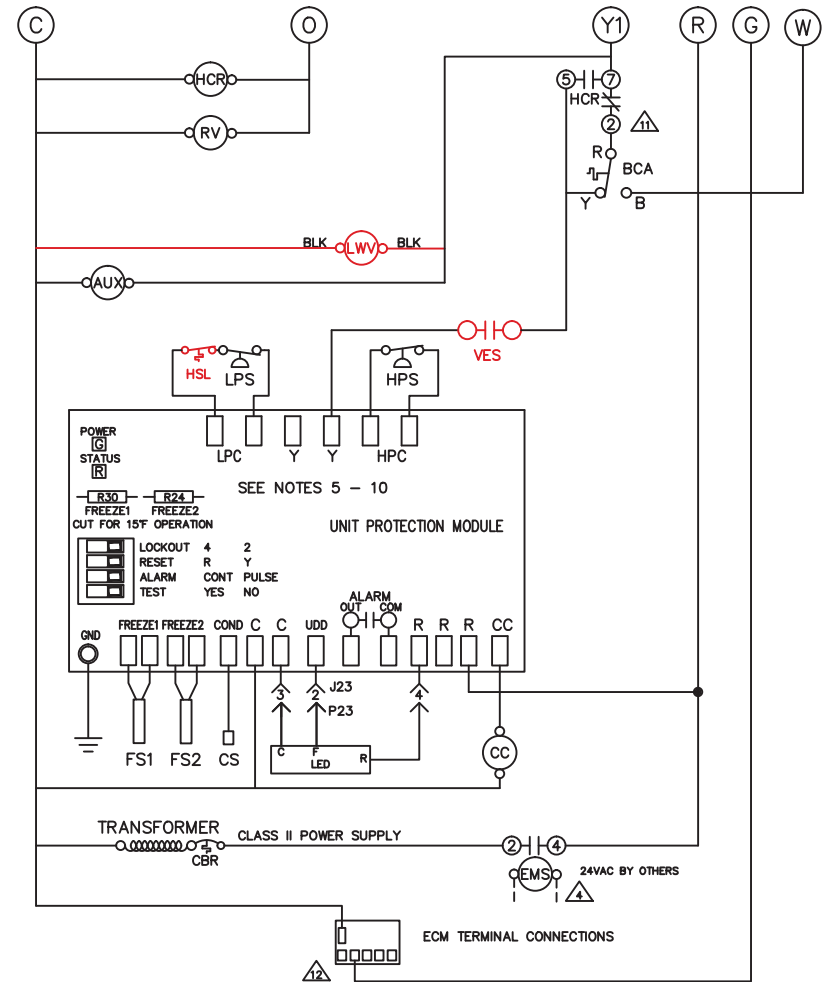

1 STAGE - 1 PHASE - X13 MOTOR 1 1/4 THROUGH 6 TONS CAPACITY UPM I - D			
PART No.	8 733 810 287		
DWG No.	DRAWN BY:	DATE	REV
50PS111009	MLM	06/23/2016	5
E-MAIL:			

Fig. 17 — Constant Torque Motor, Single Phase/Single Stage, Deluxe D Control

UPM STATUS LED - BLINK CODES	
1	HIGH PRESSURE FAULT
2	LOW PRESSURE FAULT
3	CONDENSER FREEZE CONDITION
4	CONDENSATE OVERFLOW FAULT
5	BROWNOUT FAULT
6	EVAPORATOR FREEZE CONDITION

FACTORY WIRE ———
FIELD WIRE - - - - -

STANDARD COMPONENTS LEGEND:

- AUX - AUXILIARY RELAY (FOR LOP PUMP, ETC)
- BM - BLOWER MOTOR
- CBR - 24V CIRCUIT BREAKER
- CAP - COMPRESSOR CAPACITOR
- CC - COMPRESSOR CONTACTOR
- CS - CONDENSATE SENSOR (IN DRAIN PAN)
- FS - FREEZE SENSOR
- HPS - HIGH PRESSURE SWITCH
- LED - UNIT STATUS LED
- LPS - LOW PRESSURE SWITCH
- RV - REVERSE VALVE(HEAT PUMPS)

OPTIONAL COMPONENTS LEGEND:

- [] HG V - HOT GAS VALVE SOLENOID (USE WITH WSHP ONLY)
- [] DS - DISCONNECT SWITCH
- [] LWV - LEAVING WATER VALVE
- [] VES - VALVE END SWITCH
- [] MVR - MOTORIZED VALVE RELAY
- [] MBV - MOTORIZED BALL VALVE
- [] F/A - FIRE ALARM RELAY CONTACTS

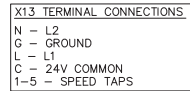
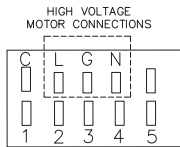

NOTES:

- SEE UNIT NAME PLATE FOR ELECTRICAL RATING.
- ALL FIELD WIRING MUST BE IN ACCORDANCE WITH N.E.C.-N.F.P.A. #70, COPPER CONDUCTORS ONLY - CONDUCTEURS EN CUIVRE SEULEMENT.
- 208/230V UNITS ARE FACTORY WIRED FOR 230V OPERATION. FOR 208V OPERATION, REMOVE LEAD FROM 240 TERMINAL AND CONNECT IT TO 208. CAP ALL UNUSED TERMINALS.
- FOR ALTERNATE EMS COIL VOLTAGES CONSULT FACTORY
- UPM-I INCLUDES BUILT IN: 270-300 SECOND RANDOM START
300 SECOND DELAY ON BREAK
120 SECOND LOW PRESSURE BYPASS
- "TEST" DIP SWITCH REDUCES DELAYS TO 10 SEC WHEN SET TO YES. MUST BE SET TO "NO" FOR NORMAL OPERATION.
- "FREEZE SENSOR" ON CONDENSER WILL OPERATE AT 26°F BY DEFAULT, IF 15°F OPERATION IS REQUIRED JUMPER R30 MUST BE CUT IF FREEZE SENSOR IS NOT INSTALLED A JUMPER SHALL BE INSTALLED BETWEEN THE FREEZE1 OR FREEZE2 SENSOR TERMINALS.
- "ALARM OUTPUT" DIP SWITCH MUST BE SET TO "PULSE" IF BLINKING T-STAT SERVICE LIGHT IS DESIRED.
- DEFAULT SETTINGS FOR UPM BOARD FROM FACTORY SHOWN. ALSO SEE INSTALLATION MANUAL.
- ALARM OUTPUT IS NORMALLY OPEN (NO) DRY CONTACT. IF 24 VAC IS NEEDED, CONNECT R TO ALR-COM TERMINAL. 24VAC WILL BE SENSED ON THE ALR-OUT WHEN THE UNIT IS IN ALARM CONDITION. OUTPUT WILL BE PULSED IF PULSE IS SELECTED.
- FACTORY MOUNTED LOOP PUMP OR TWO WAY WATER VALVE. BOTH DEVICES WILL NOT BE PRESENT IN THE SAME UNIT.

USE CLASS II FIELD WIRING - TO WSHP OPEN INTERFACE J1 AND J11

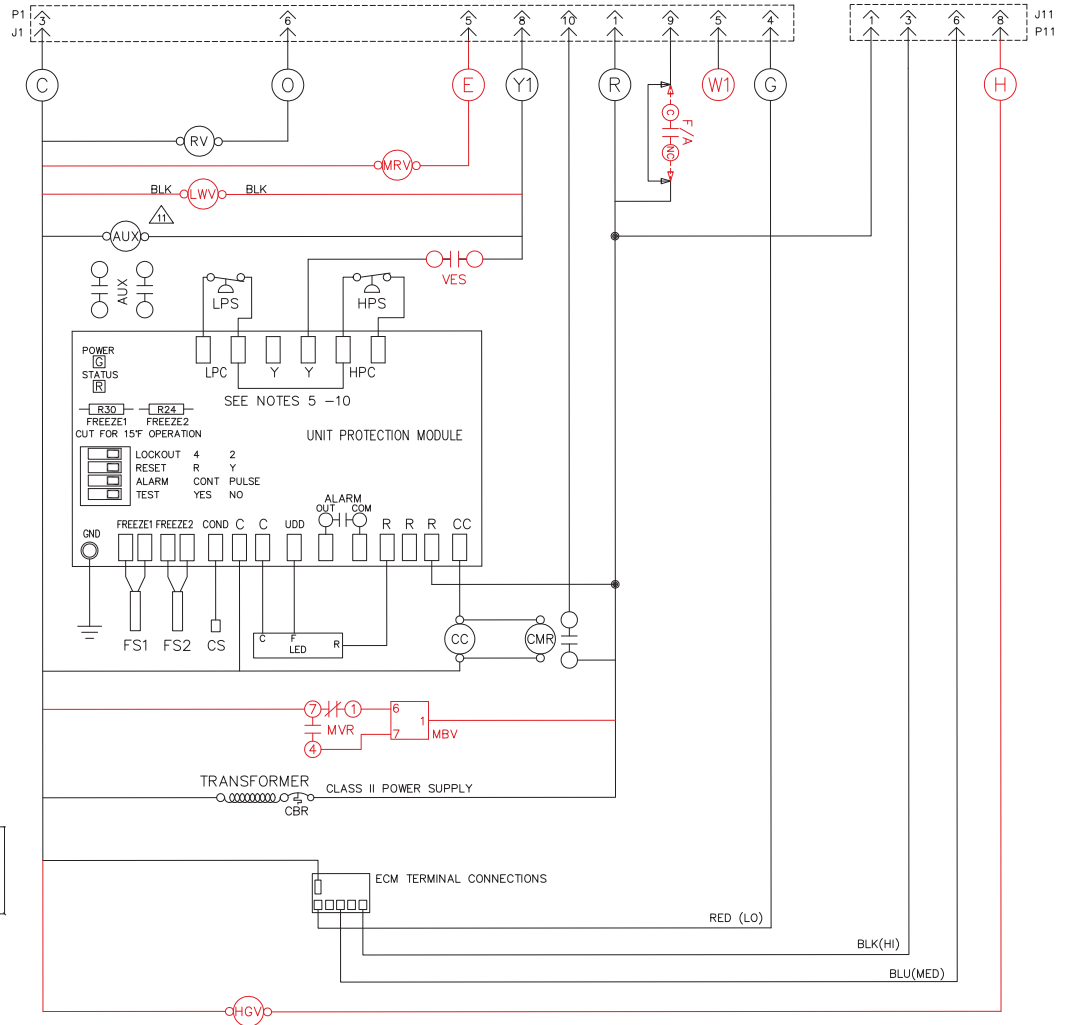

Fig. 18 — Constant Torque Motor, Single Phase, Single Stage, WSHP Open Control

UPM STATUS LED - BLINK CODES	
1	HIGH PRESSURE FAULT
2	LOW PRESSURE FAULT
3	CONDENSER FREEZE CONDITION
4	CONDENSATE OVERFLOW FAULT
5	BROWN OUT FAULT
6	EVAPORATOR FREEZE CONDITION

FACTORY WIRE —————
 FIELD WIRE - - - - -

STANDARD COMPONENTS LEGEND:

- BM - BLOWER MOTOR
- CAP - COMPRESSOR CAPACITOR
- CBR - 24V CIRCUIT BREAKER
- CC - COMPRESSOR CONTACTOR
- COMP - COMPRESSOR
- CS - CONDENSATE SENSOR (IN DRAIN PAN)
- FS - FREEZE SENSOR
- HPS - HIGH PRESSURE SWITCH
- LPS - LOW PRESSURE SWITCH
- RV - REVERSING VALVE (HEAT PUMPS)

OPTIONAL COMPONENTS LEGEND:

- [] DS - DISCONNECT SWITCH
- [] HSL - HIGH TEMPERATURE SUCTION LIMIT (WITH HOT GAS BYPASS ONLY)
- [] HRP - HEAT RECOVERY PACKAGE: HRP- HEAT RECOVERY PUMP LGL - LOW GAS TEMPERATURE LIMIT HWL - HOT WATER LIMIT SWT - ON/OFF SWITCH OVERLOAD PROTECTION
- [] LWV - LEAVING WATER VALVE
- [] VES - VALVE END SWITCH

NOTES:

1. SEE UNIT NAMEPLATE FOR ELECTRICAL RATING.
2. ALL FIELD WIRING MUST BE IN ACCORDANCE WITH NEC-NFPA #70, COPPER CONDUCTORS ONLY.
3. 208/230V UNITS ARE FACTORY WIRED FOR 230V OPERATION. FOR 208V OPERATION, REMOVE LEAD FROM 240 TERMINAL AND CONNECT IT TO 208. CAP ALL UNUSED TERMINALS.
4. UPM-1 INCLUDES BUILT IN: 270-300 SECOND RANDOM START
 300 SECOND DELAY ON BREAK
 120 SECOND LOW PRESSURE BYPASS
5. "TEST" DIP SWITCH REDUCES DELAYS TO 10 SEC WHEN SET TO YES. MUST BE SET TO "NO" FOR NORMAL OPERATION.
6. "FREEZE SENSOR" ON CONDENSER WILL OPERATE AT 26 F BY DEFAULT, IF 15 F OPERATION IS REQUIRED JUMPER R30 MUST BE CUT. IF FREEZE SENSOR IS NOT INSTALLED A JUMPER SHALL BE INSTALLED BETWEEN THE FREEZE1 OR FREEZE2 SENSOR TERMINALS.
7. "ALARM OUTPUT" DIP SWITCH MUST BE SET TO "PULSE" IF BLINKING T-STAT SERVICE LIGHT IS DESIRED.
8. DEFAULT SETTINGS FOR UPM BOARD FROM FACTORY SHOWN.
9. ALARM OUTPUT IS NORMALLY OPEN (NO) DRY CONTACT. IF 24 VAC IS NEEDED, CONNECT R TO ALR-COM TERMINAL. 24 VAC WILL BE SENSED ON THE ALR-OUT WHEN THE UNIT IS IN ALARM CONDITION. OUTPUT WILL BE PULSED IF PULSE IS SELECTED.
10. FACTORY-MOUNTED LOOP PUMP OR TWO-WAY WATER VALVE. BOTH DEVICES WILL NOT BE PRESENT IN THE SAME UNIT.

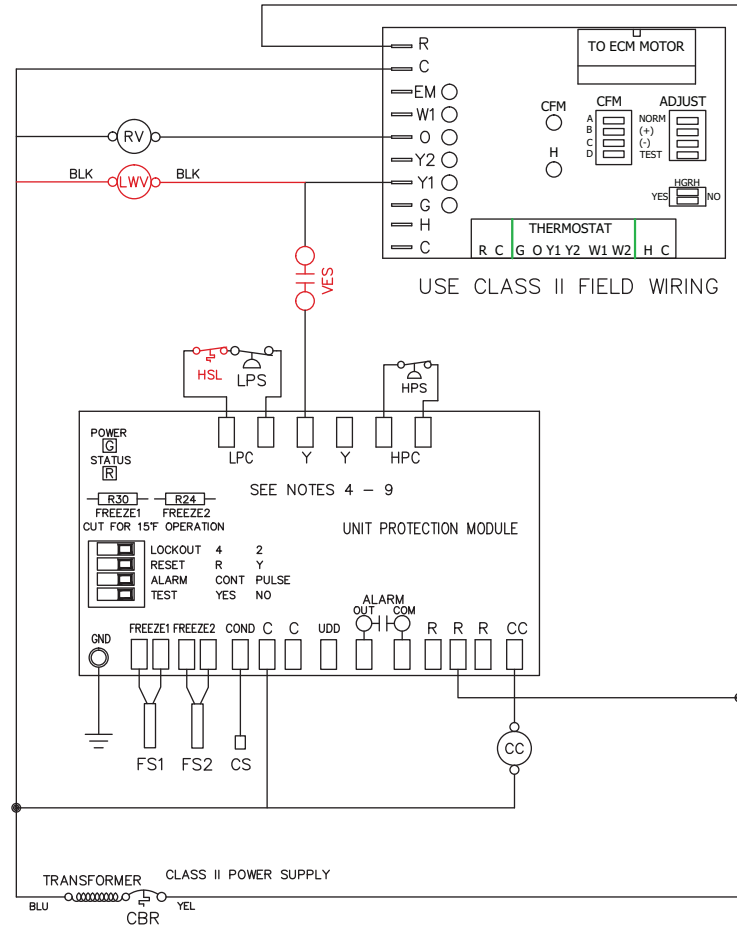
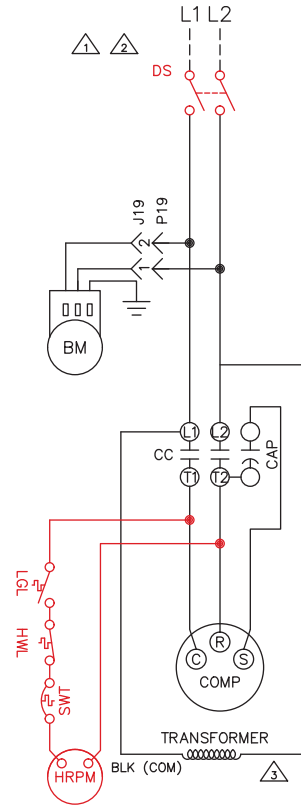

1 STAGE - 1 PHASE - EON MOTOR			
1 1/4 THROUGH 6 TONS CAPACITY			
UPM I - C			
PART No.	8 733 810 190		
DWG No.	DRAWN BY:	DATE	REV
50PS111002	MLM	06/23/2016	3
E-MAIL:			

Fig. 19 — Constant Airflow Motor, Single Phase/Single Stage, Complete C Control

UPM STATUS LED - BLINK CODES	
1	HIGH PRESSURE FAULT
2	LOW PRESSURE FAULT
3	CONDENSER FREEZE CONDITION
4	CONDENSATE OVERFLOW FAULT
5	BROWN OUT FAULT
6	EVAPORATOR FREEZE CONDITION

FACTORY WIRE —————
FIELD WIRE - - - - -

STANDARD COMPONENTS LEGEND:

- AUX - AUXILIARY RELAY (FOR LOOP PUMP, ETC)
- BCA - BOILERLESS CONTROL AQUASTAT
- BM - BLOWER MOTOR
- CAP - COMPRESSOR CAPACITOR
- CBR - 24V CIRCUIT BREAKER
- CC - COMPRESSOR CONTACTOR
- COMP - COMPRESSOR
- CS - CONDENSATE SENSOR (IN DRAIN PAN)
- EMS - ENERGY MGMT SYSTEM RELAY
- FS - FREEZE SENSOR
- HCR - HEATING/COOLING RELAY
- HPS - HIGH PRESSURE SWITCH
- LED - UNIT STATUS LED
- LP - LOOP PUMP (FIELD INSTALLED)
- LPS - LOW PRESSURE SWITCH
- RV - REVERSING VALVE (HEAT PUMPS)

OPTIONAL COMPONENTS LEGEND:

- [] DS - DISCONNECT SWITCH
- [] HRP - HEAT RECOVERY PACKAGE
- [] HRP - HEAT RECOVERY PUMP
- [] LGL - LOW GAS TEMPERATURE LIMIT
- [] HWL - HOT WATER LIMIT
- [] SWT - ON/OFF SWITCH OVERLOAD PROTECTION (WITH HOT GAS BYPASS ONLY)
- [] HSL - HIGH TEMPERATURE SUCTION LIMIT (WITH HOT GAS BYPASS ONLY)
- [] LWV - LEAVING WATER VALVE
- [] VES - VALVE END SWITCH

NOTES:

1. SEE UNIT NAMEPLATE FOR ELECTRICAL RATING.
2. ALL FIELD WIRING MUST BE IN ACCORDANCE WITH NEC-NFPA #70, COPPER CONDUCTORS ONLY.
3. 208/230V UNITS ARE FACTORY WIRED FOR 230V OPERATION. FOR 208V OPERATION, REMOVE LEAD FROM 240 TERMINAL AND CONNECT IT TO 208. CAP ALL UNUSED TERMINALS.
4. FOR ALTERNATIVE EMS COIL VOLTAGES CONSULT FACTORY.
5. UPM-1 INCLUDES BUILT IN: 270-300 SECOND RANDOM START 300 SECOND DELAY ON BREAK 120 SECOND LOW PRESSURE BYPASS
6. "TEST" DIP SWITCH REDUCES DELAYS TO 10 SEC WHEN SET TO YES. MUST BE SET TO "NO" FOR NORMAL OPERATION.
7. "FREEZE SENSOR" ON CONDENSER WILL OPERATE AT 26 F BY DEFAULT, IF 15 F OPERATION IS REQUIRED JUMPER R30 MUST BE CUT. IF FREEZE SENSOR IS NOT INSTALLED A JUMPER SHALL BE INSTALLED BETWEEN THE FREEZE1 OR FREEZE2 SENSOR TERMINALS.
8. "ALARM OUTPUT" DIP SWITCH MUST BE SET TO "PULSE" IF BLINKING T-STAT SERVICE LIGHT IS DESIRED.
9. DEFAULT SETTINGS FOR UPM BOARD FROM FACTORY SHOWN.
10. ALARM OUTPUT IS NORMALLY OPEN (NO) DRY CONTACT. IF 24 VAC IS NEEDED, CONNECT R TO ALR-COM TERMINAL. 24 VAC WILL BE SENSED ON THE ALR-OUT WHEN THE UNIT IS IN ALARM CONDITION. OUTPUT WILL BE PULSED IF PULSE IS SELECTED.
11. FACTORY-MOUNTED LOOP PUMP OR TWO-WAY WATER VALVE. BOTH DEVICES WILL NOT BE PRESENT IN THE SAME UNIT.
12. BCA CONTACTS R-Y OPEN ON DROP IN WATER TEMPERATURE AND R-B CLOSE.

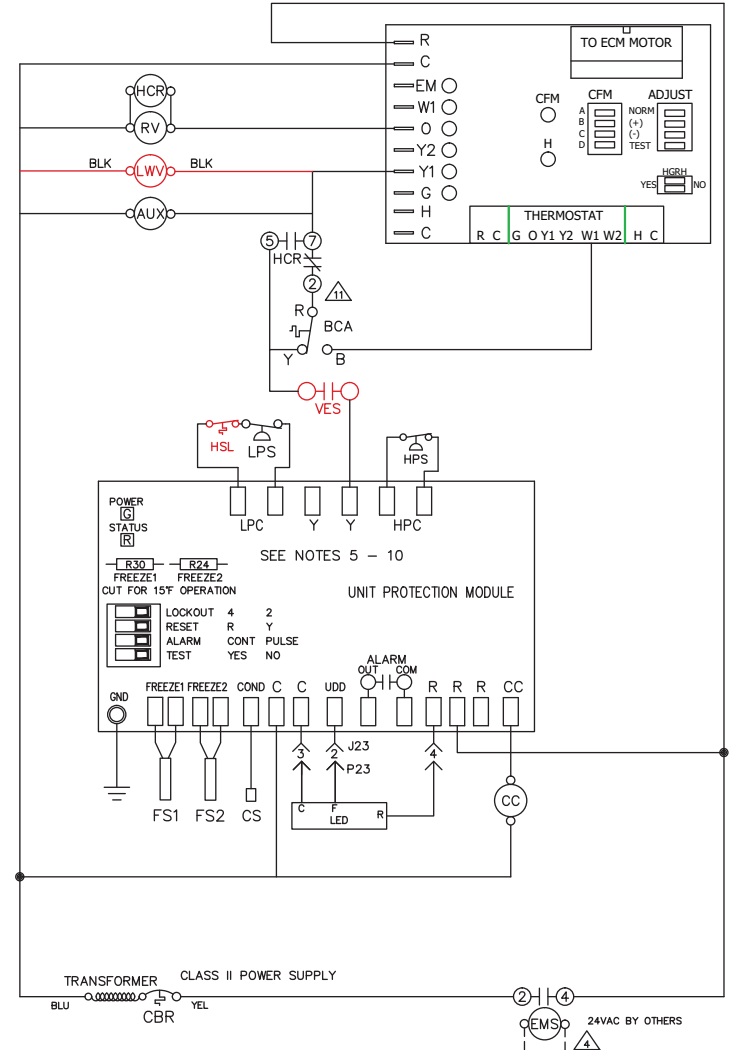
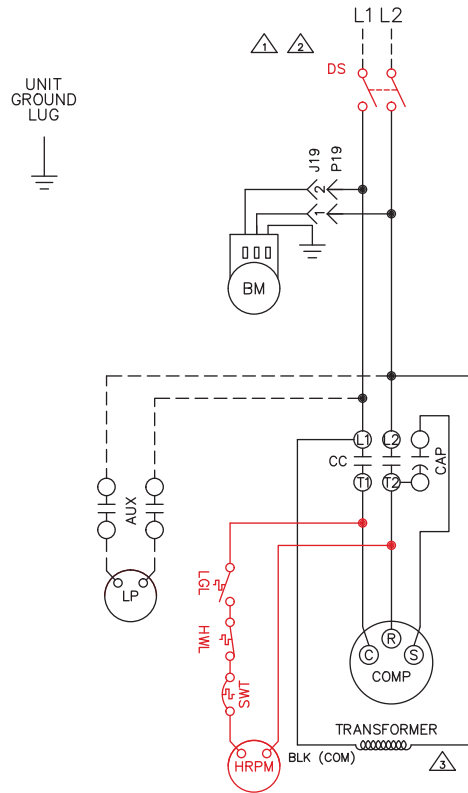

1 STAGE - 1 PHASE - EON MOTOR 1 1/4 THROUGH 6 TONS CAPACITY UPM I - D			
PART No.	8 733 810 289		
DWG No.	DRAWN BY:	DATE	REV
50PS111011	MLM	06/23/2016	4
E-MAIL:			

Fig. 20 — Constant Airflow Motor, Single Phase/Single Stage, Deluxe D

UPM STATUS LED - BLINK CODES	
1	HIGH PRESSURE FAULT
2	LOW PRESSURE FAULT
3	CONDENSER FREEZE CONDITION
4	CONDENSATE OVERFLOW FAULT
5	BROWNOUT FAULT
6	EVAPORATOR FREEZE CONDITION

FACTORY WIRE _____
FIELD WIRE - - - - -

- STANDARD COMPONENTS LEGEND:**
- BM - BLOWER MOTOR
 - COMP - COMPRESSOR
 - CBR - 24V CIRCUIT BREAKER
 - CAP - COMPRESSOR CAPACITOR
 - CC - COMPRESSOR CONTACTOR
 - CS - CONDENSATE SENSOR
 - (IN DRAIN PAN)
 - FS - FREEZE SENSOR
 - HPS - HIGH PRESSURE SWITCH
 - LPS - LOW PRESSURE SWITCH
 - RV - REVERSE VALVE(HEAT PUMPS)

- OPTIONAL COMPONENTS LEGEND:**
- [] F/A - FIRE ALARM RELAY
 - [] DS - DISCONNECT SWITCH
 - [] HSL - HIGH TEMP SUCTION LIMIT (WITH HOT GAS BYPASS ONLY)
 - [] LWV - LEAVING WATER VALVE
 - [] VES - VALVE END SWITCH
 - [] HRP - HEAT RECOVERY PACKAGE, INCLUDES:
 - HRPM - HEAT RECOVERY PUMP
 - LGL - LOW GAS TEMP LIMIT
 - HWL - HOT WATER LIMIT
 - SWT - ON/OFF SWITCH OVERLOAD PROTECTION
 - [] Y2S - SECOND STAGE SOLENOID (SHIFTS COMP TO FULL CAPACITY)

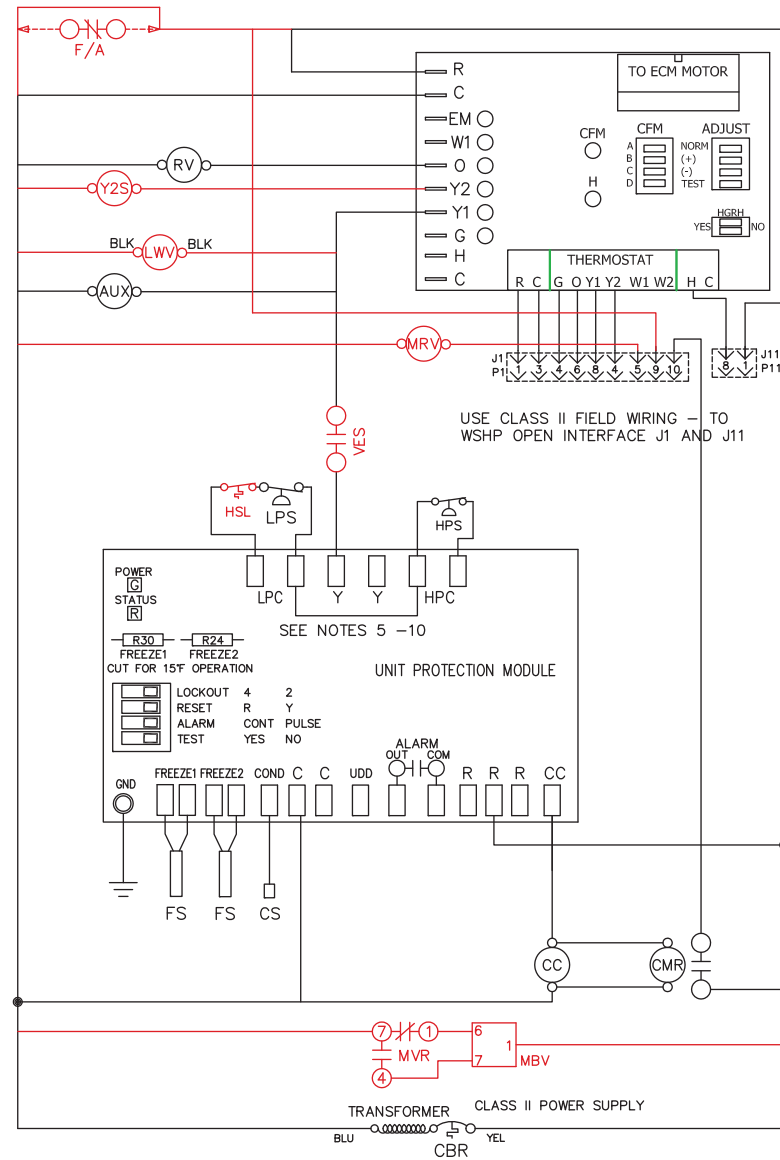
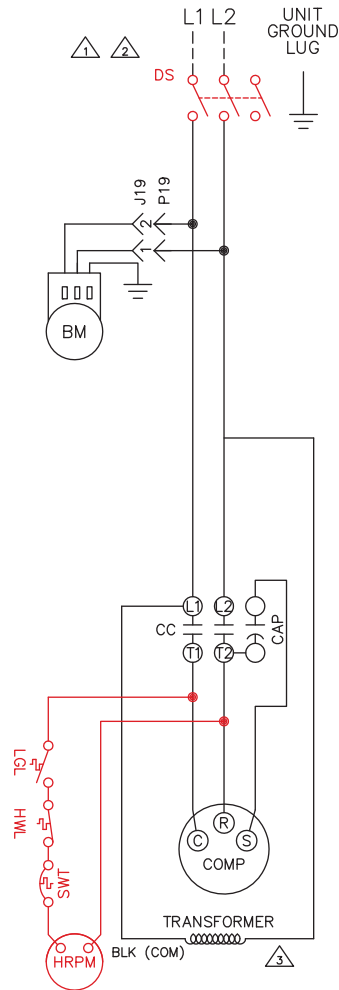

1 STAGE - 1 PHASE EON MOTOR 1/2 THROUGH 6 TONS CAPACITY UPM I - FOR USE WITH WSHP-I			
PART No. 8 733 810 834			
DWG No.	DRAWN BY:	DATE	REV
	COC	1/20/2015	1
E-MAIL:			

Fig. 21 — Constant Airflow, Single Phase, WSHP Open

TRANSFORMER PRIMARY LEAD CLR:	
120	- WHT
208	- RED
240	- ORG
277	- BRN
380	- PUR OR YEL
460	- BLK/RED
575	- GRV

UPM STATUS LED - BLINK CODES	
1	HIGH PRESSURE FAULT
2	LOW PRESSURE FAULT
3	CONDENSER FREEZE CONDITION
4	CONDENSATE OVERFLOW FAULT
5	BROWN OUT FAULT
6	EVAPORATOR FREEZE CONDITION

FACTORY WIRE _____
FIELD WIRE - - - - -

STANDARD COMPONENTS LEGEND:

- BC - BLOWER MOTOR CAPACITOR
- BM - BLOWER MOTOR
- BR - BLOWER RELAY
- CBR - 24V CIRCUIT BREAKER
- CC - COMPRESSOR CONTACTOR
- COMP - COMPRESSOR
- CS - CONDENSATE SENSOR (IN DRAIN PAN)
- FS - FREEZE SENSOR
- HPS - HIGH PRESSURE SWITCH
- LPS - LOW PRESSURE SWITCH
- RV - REVERSING VALVE (HEAT PUMPS)

OPTIONAL COMPONENTS LEGEND:

- [] DS - DISCONNECT SWITCH
- [] HRP - HEAT RECOVERY PACKAGE:
- [] HRPM - HEAT RECOVERY PUMP
- [] LGL - LOW GAS TEMPERATURE LIMIT
- [] HWL - HOT WATER LIMIT
- [] SWT - ON/OFF SWITCH OVERLOAD PROTECTION
- [] HSL - HIGH TEMPERATURE SUCTION LIMIT (WITH HOT GAS BYPASS ONLY)
- [] LWV - LEAVING WATER VALVE
- [] VES - VALVE END SWITCH

NOTES:

- SEE UNIT NAMEPLATE FOR ELECTRICAL RATING.
- ALL FIELD WIRING MUST BE IN ACCORDANCE WITH NEC-NFPA #70, COPPER CONDUCTORS ONLY.
- 208/230V UNITS ARE FACTORY WIRED FOR 230V OPERATION. FOR 208V OPERATION, REMOVE LEAD FROM 240 TERMINAL AND CONNECT IT TO 208. CAP ALL UNUSED TERMINALS.
- UPM-1 INCLUDES BUILT IN: 270-300 SECOND RANDOM START
300 SECOND DELAY ON BREAK
120 SECOND LOW PRESSURE BYPASS
- "TEST" DIP SWITCH REDUCES DELAYS TO 10 SEC WHEN SET TO YES. MUST BE SET TO "NO" FOR NORMAL OPERATION.
- "FREEZE SENSOR" ON CONDENSER WILL OPERATE AT 26 F BY DEFAULT, IF 15 F OPERATION IS REQUIRED JUMPER R30 MUST BE CUT. IF FREEZE SENSOR IS NOT INSTALLED A JUMPER SHALL BE INSTALLED BETWEEN THE FREEZE1 OR FREEZE2 SENSOR TERMINALS.
- "ALARM OUTPUT" DIP SWITCH MUST BE SET TO "PULSE" IF BLINKING T-STAT SERVICE LIGHT IS DESIRED.
- DEFAULT SETTINGS FOR UPM BOARD FROM FACTORY SHOWN.
- ALARM OUTPUT IS NORMALLY OPEN (NO) DRY CONTACT. IF 24 VAC IS NEEDED, CONNECT R TO ALR-COM TERMINAL. 24 VAC WILL BE SENSED ON THE ALR-OUT WHEN THE UNIT IS IN ALARM CONDITION. OUTPUT WILL BE PULSED IF PULSE IS SELECTED.
- TERMINAL BLOCK TB3 LOCATED INSIDE DISCONNECT SWITCH BOX.
- CHECK FOR PROPER PHASE ROTATION ON UNITS WITH SCROLL COMPRESSORS. REVERSE ROTATION WILL DAMAGE THE COMPRESSOR AND VOID UNIT WARRANTY.
- FACTORY-MOUNTED LOOP PUMP OR TWO-WAY WATER VALVE. BOTH DEVICES WILL NOT BE PRESENT IN THE SAME UNIT.
- PUMP MOTOR IS WIRED BETWEEN LINE AND NEUTRAL FOR 380-460VAC UNITS. FOR 208/230VAC UNITS PUMP MOTOR IS WIRED BETWEEN LINES.
- 208/230V AND 460V BLOWER MOTORS HAVE THREE SPEED TAPS. 575 BLOWER MOTORS ARE SINGLE SPEED. FOR 460 BLOWER MOTORS WIRE BLACK AND ORANGE LEADS TOGETHER FOR MED OR LO SPEED OPERATION. CAP UNUSED LEADS.

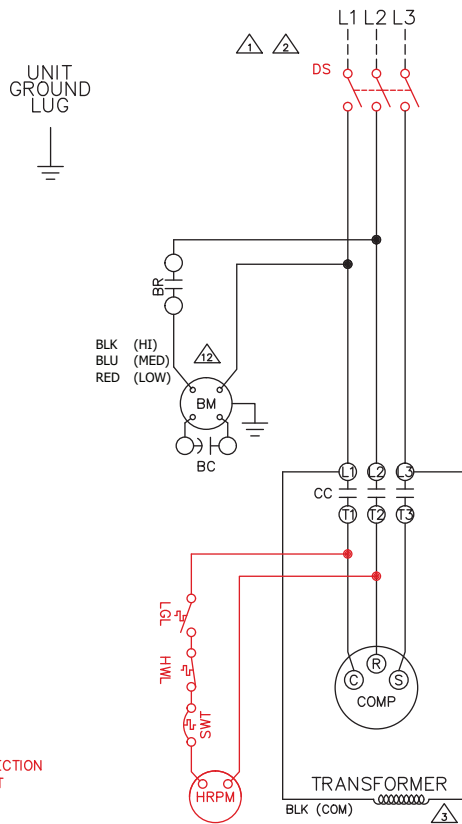

USE CLASS II FIELD WIRING

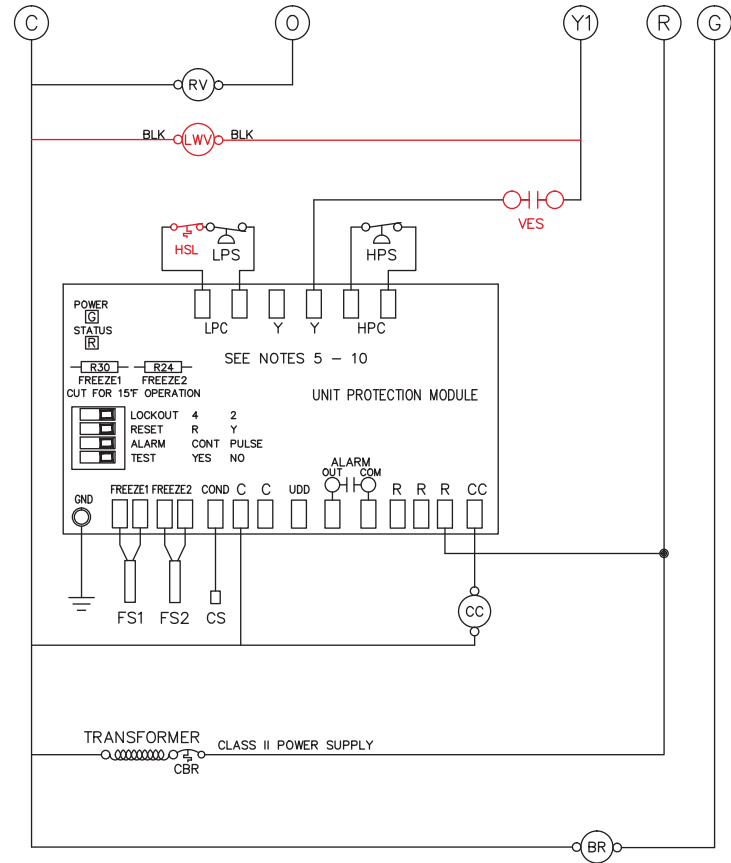

1 STAGE - 3 PHASE - PSC MOTOR 1/2 THROUGH 6 TONS CAPACITY UPM I - C			
PART No.	8 733 810 192	DATE	REV
DWG No.	50PS311001	DRAWN BY:	MLM
E-MAIL:		DATE	06/23/2016
		REV	3

Fig. 22 — PSC Motor, Three Phase/Single Stage, Complete C Control

TRANSFORMER PRIMARY LEAD CLR:	
120	- WHI
208	- RED
240	- ORG
277	- BRN
480	- PUR OR YEL
460	- BLK/RED
575	- GRV

UPM STATUS LED - BLINK CODES	
1	HIGH PRESSURE FAULT
2	LOW PRESSURE FAULT
3	CONDENSER FREEZE CONDITION
4	CONDENSATE OVERFLOW FAULT
5	BROWN OUT FAULT
6	EVAPORATOR FREEZE CONDITION

FACTORY WIRE ———
FIELD WIRE - - - - -

STANDARD COMPONENTS LEGEND:

AUX - AUXILIARY RELAY
(FOR LOOP PUMP, ETC)
BCA - BOILERLESS CONTROL AQUASTAT
BC - BLOWER MOTOR CAPACITOR
BM - BLOWER MOTOR
BR - BLOWER RELAY
CBR - 24V CIRCUIT BREAKER
CC - COMPRESSOR CONTACTOR
COMP - COMPRESSOR
CS - CONDENSATE SENSOR (IN DRAIN PAN)
EMS - ENERGY MGMT SYSTEM RELAY
FS - FREEZE SENSOR
HCR - HEATING/COOLING RELAY
HPS - HIGH PRESSURE SWITCH
LED - UNIT STATUS LED
LP - LOOP PUMP (FIELD INSTALLED)
LPS - LOW PRESSURE SWITCH
PM - PHASE MONITOR
RV - REVERSING VALVE (HEAT PUMPS)

OPTIONAL COMPONENTS LEGEND:

[] DS - DISCONNECT SWITCH
[] HRP - HEAT RECOVERY PACKAGE:
HRPM - HEAT RECOVERY PUMP
LGL - LOW GAS TEMPERATURE LIMIT
HWL - HOT WATER LIMIT
SWT - ON/OFF SWITCH OVERLOAD PROTECTION
[] HSL - HIGH TEMPERATURE SUCTION LIMIT
(WITH HOT GAS BYPASS ONLY)
[] LWV - LEAVING WATER VALVE
[] TB2 - MAIN TERMINAL BLOCK (460V UNITS ONLY)
[] TB3 - TERMINAL BLOCK DISCONNECT SWITCH
[] VES - VALVE END SWITCH

UNIT
GROUND
LUG

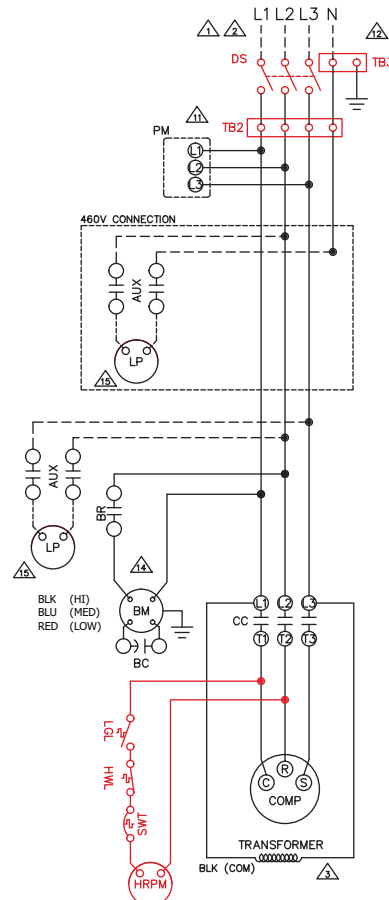

USE CLASS II FIELD WIRING H-STAT CONNECTION BLOCK

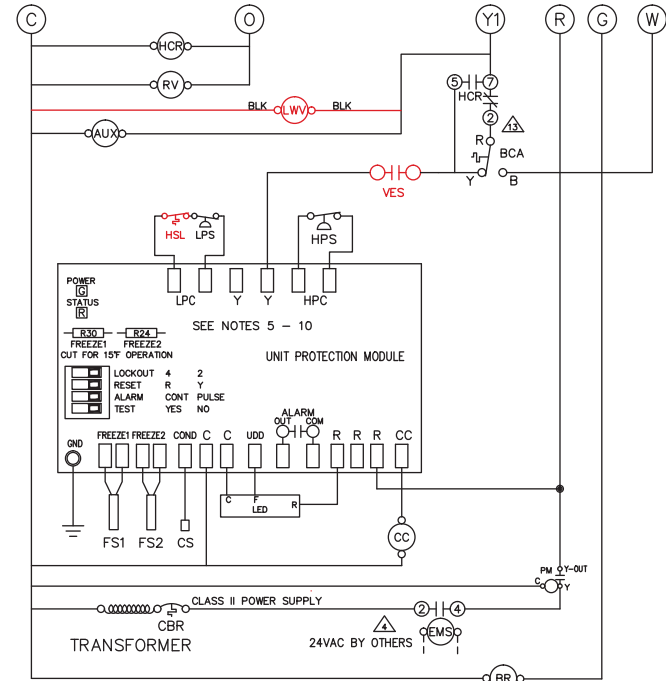

NOTES:

- SEE UNIT NAMEPLATE FOR ELECTRICAL RATING.
- ALL FIELD WIRING MUST BE IN ACCORDANCE WITH NEC-NFPA #70, COPPER CONDUCTORS ONLY.
- 208/230V UNITS ARE FACTORY WIRED FOR 230V OPERATION. FOR 208V OPERATION, REMOVE LEAD FROM 240 TERMINAL AND CONNECT IT TO 208. CAP ALL UNUSED TERMINALS.
- FOR ALTERNATIVE EMS COIL VOLTAGES CONSULT FACTORY.
- UPM-1 INCLUDES BUILT IN: 270-300 SECOND RANDOM START
300 SECOND DELAY ON BREAK
120 SECOND LOW PRESSURE BYPASS
- "TEST" DIP SWITCH REDUCES DELAYS TO 10 SEC WHEN SET TO YES. MUST BE SET TO "NO" FOR NORMAL OPERATION.
- "FREEZE SENSOR" ON CONDENSER WILL OPERATE AT 26 F BY DEFAULT, IF 15 F OPERATION IS REQUIRED JUMPER R30 MUST BE CUT. IF FREEZE SENSOR IS NOT INSTALLED A JUMPER SHALL BE INSTALLED BETWEEN THE FREEZE1 OR FREEZE2 SENSOR TERMINALS.
- "ALARM OUTPUT" DIP SWITCH MUST BE SET TO "PULSE" IF BLINKING T-STAT SERVICE LIGHT IS DESIRED.
- DEFAULT SETTINGS FOR UPM BOARD FROM FACTORY SHOWN.
- ALARM OUTPUT IS NORMALLY OPEN (NO) DRY CONTACT. IF 24 VAC IS NEEDED, CONNECT R TO ALR-COM TERMINAL. 24 VAC WILL BE SENSED ON THE ALR-OUT WHEN THE UNIT IS IN ALARM CONDITION. OUTPUT WILL BE PULSED IF PULSE IS SELECTED.
- TERMINAL BLOCK TB3 LOCATED INSIDE DISCONNECT SWITCH BOX.
- CHECK FOR PROPER PHASE ROTATION ON UNITS WITH SCROLL COMPRESSORS. REVERSE ROTATION WILL DAMAGE THE COMPRESSOR AND VOID UNIT WARRANTY.
- FACTORY-MOUNTED LOOP PUMP OR TWO-WAY WATER VALVE. BOTH DEVICES WILL NOT BE PRESENT IN THE SAME UNIT.
- PUMP MOTOR IS WIRED BETWEEN LINE AND NEUTRAL FOR 380-460VAC UNITS. FOR 208/230VAC UNITS PUMP MOTOR IS WIRED BETWEEN LINES.
- 208/230V AND 460V BLOWER MOTORS HAVE THREE SPEED TAPS. 575 BLOWER MOTORS ARE SINGLE SPEED. FOR 460 BLOWER MOTORS WIRE BLACK AND ORANGE LEADS TOGETHER FOR MED OR LO SPEED OPERATION. CAP UNUSED LEADS.
- BCA CONTACTS R-Y OPEN ON DROP IN WATER TEMPERATURE AND R-B CLOSE.

1 STAGE - 3 PHASE - PSC MOTOR 1/2 THROUGH 1 TONS CAPACITY UPM I - D			
PART No.	8 733 810 291		
DWG No.	DRAWN BY:	DATE	REV
50PS311010	MLM	07/14/2016	5
E-MAIL:			

Fig. 23 — PSC Motor, Three Phase/Single Stage, E-Heat, Deluxe D Control

UPM STATUS LED - BLINK CODES	
1	HIGH PRESSURE FAULT
2	LOW PRESSURE FAULT
3	CONDENSER FREEZE CONDITION
4	CONDENSATE OVERFLOW FAULT
5	BROWNOUT FAULT
6	EVAPORATOR FREEZE CONDITION

FACTORY WIRE —————
FIELD WIRE - - - - -

STANDARD COMPONENTS LEGEND:

- AUX - AUXILIARY RELAY (FOR LOP PUMP, ETC)
- BC - BLOWER CAPACITOR
- BM - BLOWER MOTOR
- BR - BLOWER RELAY (1-3)
- CBR - 24V CIRCUIT BREAKER
- CAP - COMPRESSOR CAPACITOR
- CC - COMPRESSOR CONTACTOR
- CS - CONDENSATE SENSOR (IN DRAIN PAN)
- FS - FREEZE SENSOR
- HPS - HIGH PRESSURE SWITCH
- LED - UNIT STATUS LED
- LP - LOOP PUMP
- LPS - LOW PRESSURE SWITCH
- RV - REVERSE VALVE(HEAT PUMPS)

OPTIONAL COMPONENTS LEGEND:

- [] HGV - HOT GAS VALVE SOLENOID (USE WITH WSHP ONLY)
- [] DS - DISCONNECT SWITCH
- [] LWV - LEAVING WATER VALVE
- [] VES - VALVE END SWITCH
- [] MVR - MOTORIZED VALVE RELAY
- [] MBV - MOTORIZED BALL VALVE

UNIT GROUND LUG

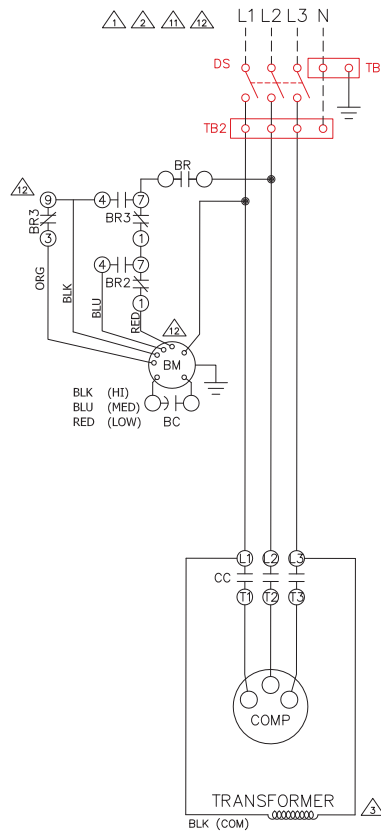

USE CLASS II FIELD WIRING - TO WSHP OPEN INTERFACE J1 AND J11

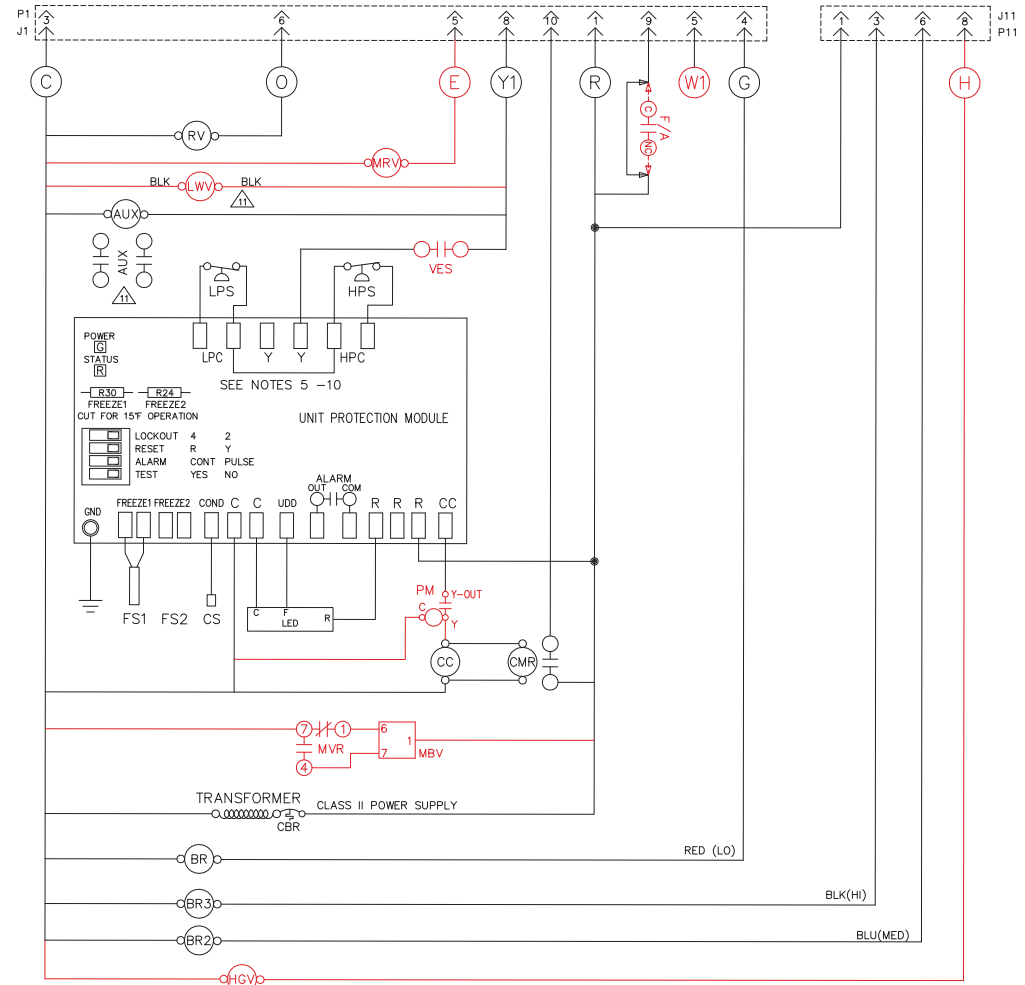

NOTES:

1. SEE UNIT NAME PLATE FOR ELECTRICAL RATING.
2. ALL FIELD WIRING MUST BE IN ACCORDANCE WITH N.E.C.-N.F.P.A. #70, COPPER CONDUCTORS ONLY - CONDUCTEURS EN CUIVRE SEULEMENT.
3. 208/230V UNITS ARE FACTORY WIRED FOR 230V OPERATION. FOR 208V OPERATION, REMOVE LEAD FROM 240 TERMINAL AND CONNECT IT TO 208. CAP ALL UNUSED TERMINALS.
4. FOR ALTERNATE EMS COIL VOLTAGES CONSULT FACTORY
5. UPM-I INCLUDES BUILT IN: 270-300 SECOND RANDOM START
300 SECOND DELAY ON BREAK
120 SECOND LOW PRESSURE BYPASS
6. "TEST" DIP SWITCH REDUCES DELAYS TO 10 SEC WHEN SET TO YES. MUST BE SET TO "NO" FOR NORMAL OPERATION.
7. "FREEZE SENSOR" ON CONDENSER WILL OPERATE AT 26°F BY DEFAULT, IF 15°F OPERATION IS REQUIRED JUMPER R30 MUST BE CUT IF FREEZE SENSOR IS NOT INSTALLED A JUMPER SHALL BE INSTALLED BETWEEN THE FREEZE1 OR FREEZE2 SENSOR TERMINALS.
8. "ALARM OUTPUT" DIP SWITCH MUST BE SET TO "PULSE" IF BLINKING T-STAT SERVICE LIGHT IS DESIRED.
9. DEFAULT SETTINGS FOR UPM BOARD FROM FACTORY SHOWN. ALSO SEE INSTALLATION MANUAL.
10. ALARM OUTPUT IS NORMALLY OPEN (NO) DRY CONTACT. IF 24 VAC IS NEEDED, CONNECT R TO ALR-COM TERMINAL, 24VAC WILL BE SENSED ON THE ALR-OUT WHEN THE UNIT IS IN ALARM CONDITION. OUTPUT WILL BE PULSED IF PULSE IS SELECTED.
11. FACTORY MOUNTED LOOP PUMP OR TWO WAY WATER VALVE. BOTH DEVICES WILL NOT BE PRESENT IN THE SAME UNIT.
12. 575 VOLT MOTORS ONLY SUPPORT A SINGLE SPEED OPERATION. 460 VOLT MOTORS WILL SHORT ORAN AND BLACK LEADS DURING LOW AND MEDIUM OPERATION

Fig. 24 — PSC Motor, Three Phase/Single Stage, WSHP Open

TRANSFORMER PRIMARY LEAD CLR:	
120	- WHT
208	- RED
240	- ORG
277	- DRN
380	- PUR OR YEL
460	- BLK/RED
575	- GRV

UPM STATUS LED - BLINK CODES	
1	HIGH PRESSURE FAULT
2	LOW PRESSURE FAULT
3	CONDENSER FREEZE CONDITION
4	CONDENSATE OVERFLOW FAULT
5	BROWN OUT FAULT
6	EVAPORATOR FREEZE CONDITION

FACTORY WIRE —————
FIELD WIRE - - - - -

STANDARD COMPONENTS LEGEND:

BM - BLOWER MOTOR
CBR - 24V CIRCUIT BREAKER
CC - COMPRESSOR CONTACTOR
COMP - COMPRESSOR
CS - CONDENSATE SENSOR (IN DRAIN PAN)
FS - FREEZE SENSOR
HPS - HIGH PRESSURE SWITCH
LPS - LOW PRESSURE SWITCH
RV - REVERSING VALVE (HEAT PUMPS)

OPTIONAL COMPONENTS LEGEND:

[] DS - DISCONNECT SWITCH
[] HRP - HEAT RECOVERY PACKAGE:
HRPM - HEAT RECOVERY PUMP
LGL - LOW GAS TEMPERATURE LIMIT
HWL - HOT WATER LIMIT
SWT - ON/OFF SWITCH OVERLOAD PROTECTION
[] HSL - HIGH TEMPERATURE SUCTION LIMIT
(WITH HOT GAS BYPASS ONLY)
[] LWV - LEAVING WATER VALVE
[] YES - VALVE END SWITCH

UNIT GROUND LUG

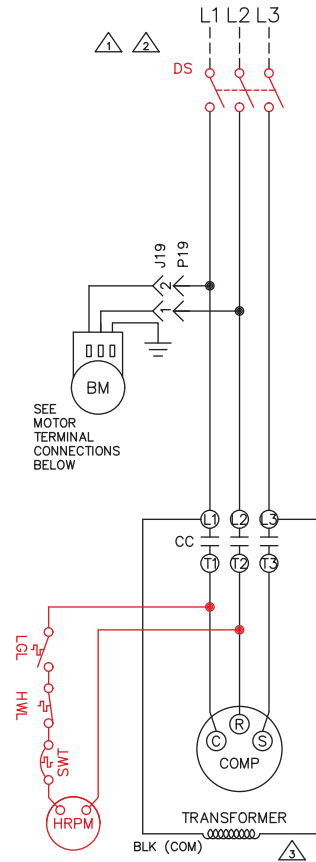

USE CLASS II FIELD WIRING

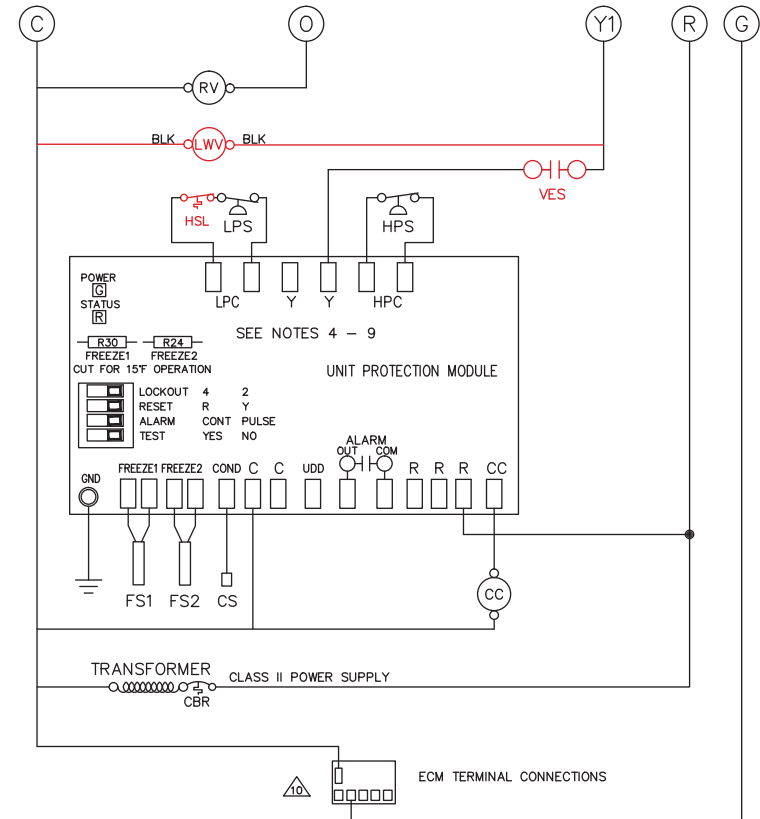

HIGH VOLTAGE MOTOR CONNECTIONS

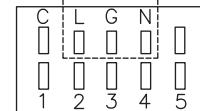

X13 TERMINAL CONNECTIONS	
N	- L2
G	- GROUND
L	- L1
C	- 24V COMMON
1-5	- SPEED TAPS

NOTES:

- SEE UNIT NAMEPLATE FOR ELECTRICAL RATING.
- ALL FIELD WIRING MUST BE IN ACCORDANCE WITH NEC-NFPA #70, COPPER CONDUCTORS ONLY.
- 208/230V UNITS ARE FACTORY WIRED FOR 230V OPERATION. FOR 208V OPERATION, REMOVE LEAD FROM 240 TERMINAL AND CONNECT IT TO 208. CAP ALL UNUSED TERMINALS.
- UPM-1 INCLUDES BUILT IN: 270-300 SECOND RANDOM START
300 SECOND DELAY ON BREAK
120 SECOND LOW PRESSURE BYPASS
- "TEST" DIP SWITCH REDUCES DELAYS TO 10 SEC WHEN SET TO YES. MUST BE SET TO "NO" FOR NORMAL OPERATION.
- "FREEZE SENSOR" ON CONDENSER WILL OPERATE AT 26 F BY DEFAULT, IF 15 F OPERATION IS REQUIRED JUMPER R30 MUST BE CUT. IF FREEZE SENSOR IS NOT INSTALLED A JUMPER SHALL BE INSTALLED BETWEEN THE FREEZE1 OR FREEZE2 SENSOR TERMINALS.
- "ALARM OUTPUT" DIP SWITCH MUST BE SET TO "PULSE" IF BLINKING T-STAT SERVICE LIGHT IS DESIRED.
- DEFAULT SETTINGS FOR UPM BOARD FROM FACTORY SHOWN.
- ALARM OUTPUT IS NORMALLY OPEN (NO) DRY CONTACT. IF 24 VAC IS NEEDED, CONNECT R TO ALR-COM TERMINAL. 24 VAC WILL BE SENSED ON THE ALR-OUT WHEN THE UNIT IS IN ALARM CONDITION. OUTPUT WILL BE PULSED IF PULSE IS SELECTED.
- TERMINAL BLOCK TB3 LOCATED INSIDE DISCONNECT SWITCH BOX.
- CHECK FOR PROPER PHASE ROTATION ON UNITS WITH SCROLL COMPRESSORS. REVERSE ROTATION WILL DAMAGE THE COMPRESSOR AND VOID UNIT WARRANTY.
- FACTORY-MOUNTED LOOP PUMP OR TWO-WAY WATER VALVE. BOTH DEVICES WILL NOT BE PRESENT IN THE SAME UNIT.
- PUMP MOTOR IS WIRED BETWEEN LINE AND NEUTRAL FOR 380-460VAC UNITS. FOR 208/230VAC UNITS PUMP MOTOR IS WIRED BETWEEN LINES.

1 STAGE - 3 PHASE - X13 MOTOR			
1/2 THROUGH 6 TONS CAPACITY			
UPM I - C			
PART No.	8 733 810 191		
DWG No.	DRAWN BY:	DATE	REV
50PS311000	MLM	06/23/2016	4
E-MAIL:			

Fig. 25 — Constant Torque Motor, Three Phase/Single Stage, Complete C Control

CAUTION: UNIT CONTAINS TWO POWER SUPPLIES - ENSURE BOTH SUPPLIES ARE OFF BEFORE SERVICING

TRANSFORMER PRIMARY LEAD CLR:	
120	- WHI
208	- RED
240	- ORG
277	- BRN
380	- PUR OR YEL
460	- BLK/RED
575	- GRV

UPM STATUS LED - BLINK CODES
1 HIGH PRESSURE FAULT
2 LOW PRESSURE FAULT
3 CONDENSER FREEZE CONDITION
4 CONDENSATE OVERFLOW FAULT
5 BROWN OUT FAULT
6 EVAPORATOR FREEZE CONDITION

FACTORY WIRE _____
FIELD WIRE - - - - -

STANDARD COMPONENTS LEGEND:

- AUX - AUXILIARY RELAY (FOR LOOP PUMP, ETC)
- BCA - BOILERLESS CONTROL AQUASTAT
- BM - BLOWER MOTOR
- COMP - COMPRESSOR
- CBR - 24V CIRCUIT BREAKER
- CC - COMPRESSOR CONTACTOR
- CS - CONDENSATE SENSOR (IN DRAIN PAN)
- EMS - ENERGY MGMT SYSTEM RELAY
- FS - FREEZE SENSOR
- HCR - HEATING/COOLING RELAY
- HPS - HIGH PRESSURE SWITCH
- LED - UNIT STATUS DISPLAY
- LP - LOOP PUMP (FIELD INSTALLED)
- LPS - LOW PRESSURE SWITCH
- PM - PHASE MONITOR
- RV - REVERSING VALVE (HEAT PUMPS)

OPTIONAL COMPONENTS LEGEND:

- DS - DISCONNECT SWITCH
- HRP - HEAT RECOVERY PACKAGE
- HRPMP - HEAT RECOVERY PUMP
- LGL - LOW GAS TEMPERATURE LIMIT
- LWL - HOT WATER LIMIT
- SWT - ON/OFF SWITCH OVERLOAD PROTECTION
- HSL - HIGH TEMPERATURE SUCTION LIMIT (WITH HOT GAS BYPASS ONLY)
- LWV - LEAVING WATER VALVE
- TB2 - MAIN TERMINAL BLOCK (460V UNITS ONLY)
- TB3 - TERMINAL BLOCK DISCONNECT SWITCH
- VES - VALVE END SWITCH

NOTES:

- SEE UNIT NAMEPLATE FOR ELECTRICAL RATING.
- ALL FIELD WIRING MUST BE IN ACCORDANCE WITH NEC-NFPA #70, COPPER CONDUCTORS ONLY.
- 208/230V UNITS ARE FACTORY WIRED FOR 230V OPERATION. FOR 208V OPERATION, REMOVE LEAD FROM 240 TERMINAL AND CONNECT IT TO 208. CAP ALL UNUSED TERMINALS.
- FOR ALTERNATIVE EMS COIL VOLTAGE CONSULT FACTORY.
- UPM-1 INCLUDES BUILT IN: 270-300 SECOND RANDOM START 300 SECOND DELAY ON BREAK 120 SECOND LOW PRESSURE BYPASS
- "TEST" DIP SWITCH REDUCES DELAYS TO 10 SEC WHEN SET TO YES. MUST BE SET TO "NO" FOR NORMAL OPERATION.
- "FREEZE SENSOR" ON CONDENSER WILL OPERATE AT 26 F BY DEFAULT, IF 15 F OPERATION IS REQUIRED JUMPER R30 MUST BE CUT. IF FREEZE SENSOR IS NOT INSTALLED A JUMPER SHALL BE INSTALLED BETWEEN THE FREEZE1 OR FREEZE2 SENSOR TERMINALS.
- "ALARM OUTPUT" DIP SWITCH MUST BE SET TO "PULSE" IF BLINKING T-STAT SERVICE LIGHT IS DESIRED.
- DEFAULT SETTINGS FOR UPM BOARD FROM FACTORY SHOWN.
- ALARM OUTPUT IS NORMALLY OPEN (NO) DRY CONTACT. IF 24 VAC IS NEEDED, CONNECT R TO ALR-COM TERMINAL. 24 VAC WILL BE SENSED ON THE ALR-OUT WHEN THE UNIT IS IN ALARM CONDITION. OUTPUT WILL BE PULSED IF PULSE IS SELECTED.
- TERMINAL BLOCK TB3 LOCATED INSIDE DISCONNECT SWITCH BOX.
- CHECK FOR PROPER PHASE ROTATION ON UNITS WITH SCROLL COMPRESSORS. REVERSE ROTATION WILL DAMAGE THE COMPRESSOR AND VOID UNIT WARRANTY.
- FACTORY-MOUNTED LOOP PUMP OR TWO-WAY WATER VALVE. BOTH DEVICES WILL NOT BE PRESENT IN THE SAME UNIT.
- PUMP MOTOR IS WIRED BETWEEN LINE AND NEUTRAL FOR 380-460VAC UNITS. FOR 208/230VAC UNITS PUMP MOTOR IS WIRED BETWEEN LINES.
- BCA CONTACTS R-Y OPEN ON DROP IN WATER TEMPERATURE AND R-B CLOSE.

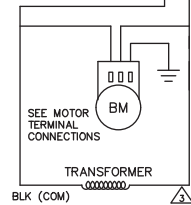
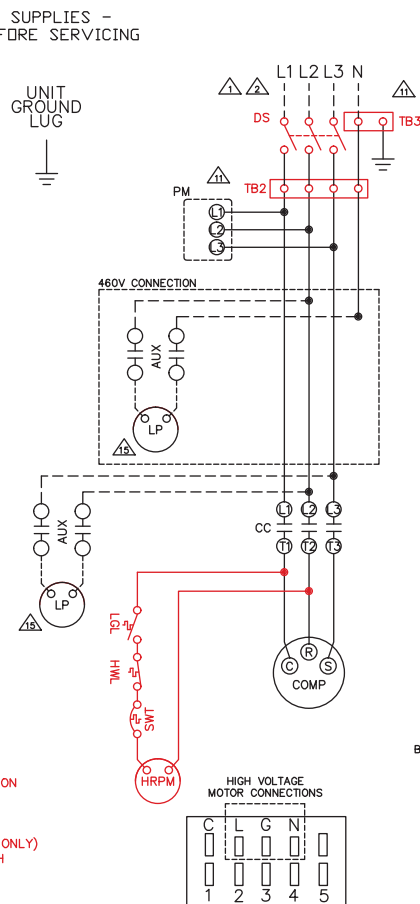

X13 TERMINAL CONNECTIONS				
N	-	L2		
G	-	GROUND		
L	-	L1		
C	-	24V COMMON		
1-5	-	SPEED TAPS		

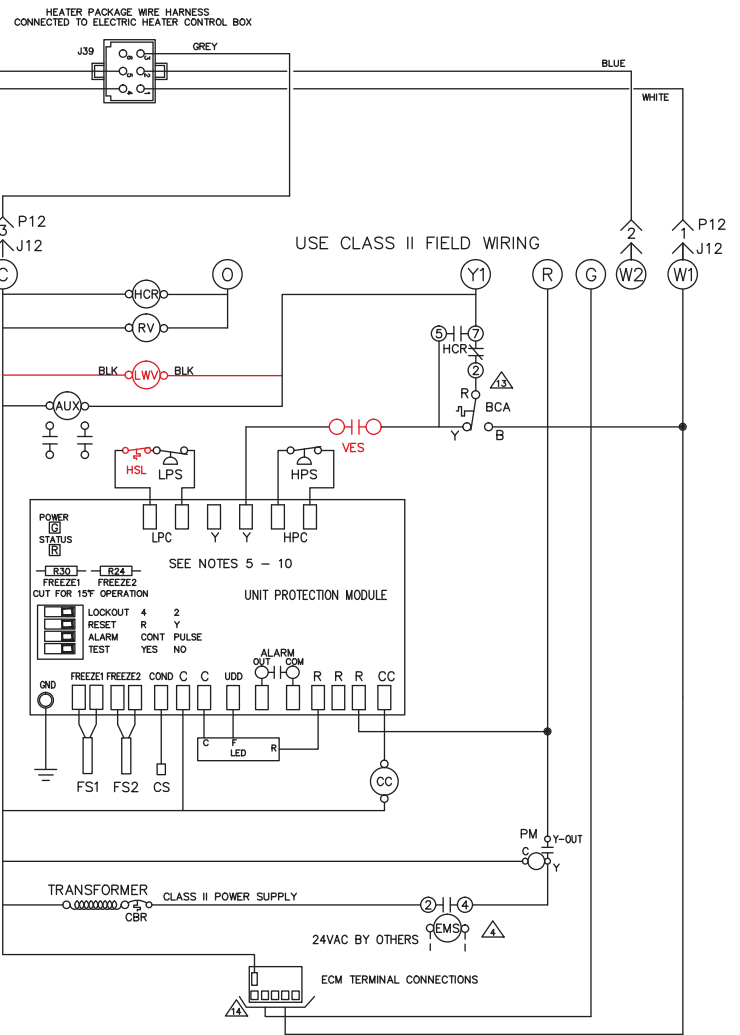

1 STAGE - 3 PHASE - X13 MOTOR 1 1/4 THROUGH 6 TONS CAPACITY UPM I - D - ELECTRIC HEAT			
PART No.	8 733 810 302		
DWG No.	50PS3111015	DRAWN BY:	MLM
		DATE	07/14/2016
E-MAIL:		REV	3

Fig. 26 — Constant Torque Motor, Three Phase/Single Stage, E-Heat, Deluxe D Control

UPM STATUS LED - BLINK CODES	
1	HIGH PRESSURE FAULT
2	LOW PRESSURE FAULT
3	CONDENSER FREEZE CONDITION
4	CONDENSATE OVERFLOW FAULT
5	BROWNOUT FAULT
6	EVAPORATOR FREEZE CONDITION

FACTORY WIRE ————
FIELD WIRE - - - - -

STANDARD COMPONENTS LEGEND:
 BM - BLOWER MOTOR
 CBR - 24V CIRCUIT BREAKER
 CAP - COMPRESSOR CAPACITOR
 CC - COMPRESSOR CONTACTOR
 CMR - COMPRESSOR MOTOR RELAY
 CS - CONDENSATE SENSOR
 (IN DRAIN PAN)
 FS - FREEZE SENSOR
 HPS - HIGH PRESSURE SWITCH
 LED - UNIT STATUS LED
 LP - LOOP PUMP
 LPS - LOW PRESSURE SWITCH
 RV - REVERSE VALVE(HEAT PUMPS)

OPTIONAL COMPONENTS LEGEND:
 [] DS - DISCONNECT SWITCH
 [] HGVS - HOT GAS VALVE SOLENOID
 (USE WITH WSHP ONLY)
 [] HSL - HIGH TEMP SUCTION LIMIT
 (WITH HOT GAS BYPASS ONLY)
 [] LWV - LEAVING WATER VALVE
 VES - VALVE END SWITCH
 [] MVR - MOTORIZED VALVE RELAY
 [] MBV - MOTORIZED BALL VALVE
 [] PM - PHASE MONITOR

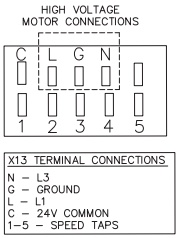
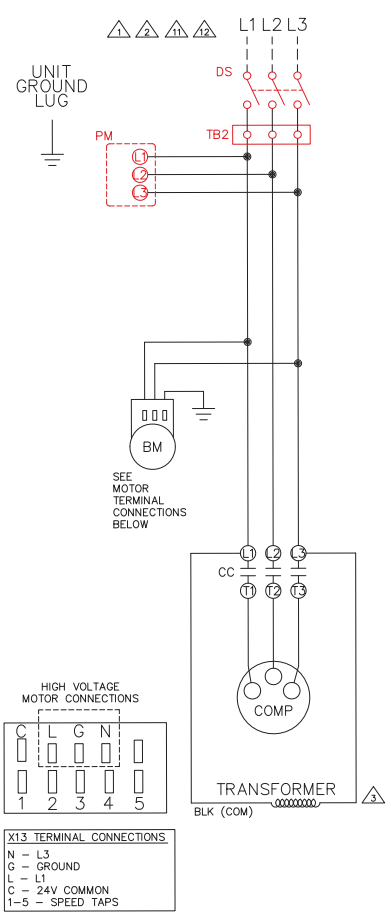

- NOTES:**
- SEE UNIT NAME PLATE FOR ELECTRICAL RATING.
 - ALL FIELD WIRING MUST BE IN ACCORDANCE WITH N.E.C.--N.F.P.A. #70, COPPER CONDUCTORS ONLY -- CONDUCTEURS EN CUIVRE SEULEMENT.
 - 208/230V UNITS ARE FACTORY WIRED FOR 230V OPERATION. FOR 208V OPERATION, REMOVE LEAD FROM 240 TERMINAL AND CONNECT IT TO 208. CAP ALL UNUSED TERMINALS.
 - FOR ALTERNATE EMS COIL VOLTAGES CONSULT FACTORY
 - UPM-I INCLUDES BUILT IN: 270-300 SECOND RANDOM START
300 SECOND DELAY ON BREAK
120 SECOND LOW PRESSURE BYPASS
 - "TEST" DIP SWITCH REDUCES DELAYS TO 10 SEC WHEN SET TO YES. MUST BE SET TO "NO" FOR NORMAL OPERATION.
 - "FREEZE SENSOR" ON CONDENSER WILL OPERATE AT 26°F BY DEFAULT, IF 15°F OPERATION IS REQUIRED JUMPER R30 MUST BE CUT IF FREEZE SENSOR IS NOT INSTALLED A JUMPER SHALL BE INSTALLED BETWEEN THE FREEZE1 OR FREEZE2 SENSOR TERMINALS.
 - "ALARM OUTPUT" DIP SWITCH MUST BE SET TO "PULSE" IF BLINKING T-STAT SERVICE LIGHT IS DESIRED.
 - DEFAULT SETTINGS FOR UPM BOARD FROM FACTORY SHOWN. ALSO SEE INSTALLATION MANUAL.
 - ALARM OUTPUT IS NORMALLY OPEN (NO) DRY CONTACT. IF 24 VAC IS NEEDED, CONNECT R TO ALR-COM TERMINAL, 24VAC WILL BE SENSED ON THE ALR-OUT WHEN THE UNIT IS IN ALARM CONDITION. OUTPUT WILL BE PULSED IF PULSE IS SELECTED.
 - FACTORY MOUNTED LOOP PUMP OR TWO WAY WATER VALVE. BOTH DEVICES WILL NOT BE PRESENT IN THE SAME UNIT.

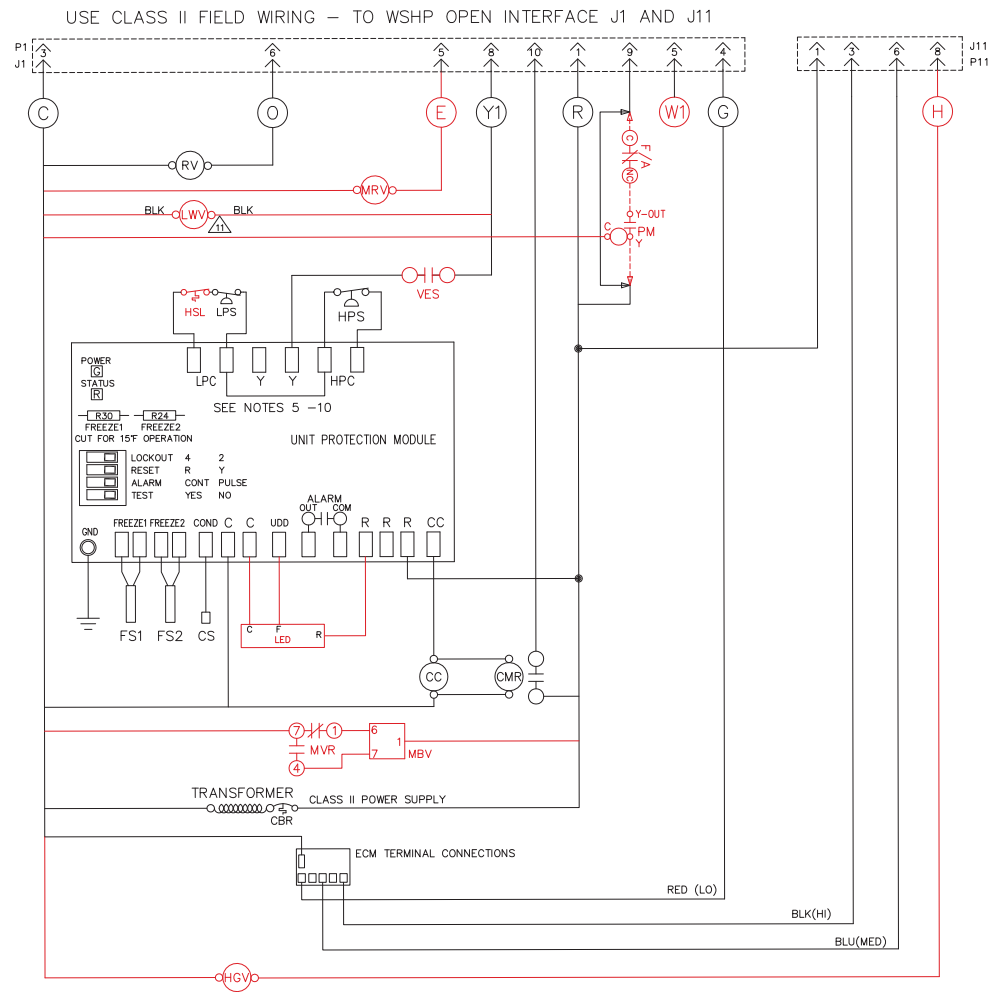

Fig. 27 — Constant Torque Motor, Three Phase/Single Stage, WSHP Open

TRANSFORMER PRIMARY LEAD CLR:	
120	- WHI
208	- RED
240	- ORG
277	- BRN
380	- PUR OR YEL
460	- BLK/RED
575	- GRY

UPM STATUS LED - BLINK CODES	
1	HIGH PRESSURE FAULT
2	LOW PRESSURE FAULT
3	CONDENSER FREEZE CONDITION
4	CONDENSATE OVERFLOW FAULT
5	BROWN OUT FAULT
6	EVAPORATOR FREEZE CONDITION

FACTORY WIRE _____
FIELD WIRE - - - - -

STANDARD COMPONENTS LEGEND:
 BM - BLOWER MOTOR
 COMP - COMPRESSOR
 CBR - 24V CIRCUIT BREAKER
 CC - COMPRESSOR CONTACTOR
 CS - CONDENSATE SENSOR (IN DRAIN PAN)
 FS - FREEZE SENSOR
 HPS - HIGH PRESSURE SWITCH
 LPS - LOW PRESSURE SWITCH
 RV - REVERSE VALVE (HEAT PUMPS)

OPTIONAL COMPONENTS LEGEND:
 [] DS - DISCONNECT SWITCH
 [] HRP - HEAT RECOVERY PACKAGE:
 HRP - HEAT RECOVERY PUMP
 LGL - LOW GAS TEMPERATURE LIMIT
 HWL - HOT WATER LIMIT
 [] SWT - ON/OFF SWITCH OVERLOAD PROTECTION
 [] HSL - HIGH TEMPERATURE SUCTION LIMIT
 (WITH HOT GAS BYPASS ONLY)
 [] LWV - LEAVING WATER VALVE
 [] TB2 - MAIN TERMINAL BLOCK (460V UNITS ONLY)
 [] TB3 - TERMINAL BLOCK DISCONNECT SWITCH
 [] VES - VALVE END SWITCH

NOTES:

- SEE UNIT NAMEPLATE FOR ELECTRICAL RATING.
- ALL FIELD WIRING MUST BE IN ACCORDANCE WITH NEC-NFPA #70, COPPER CONDUCTORS ONLY.
- 208/230V UNITS ARE FACTORY WIRED FOR 230V OPERATION. FOR 208V OPERATION, REMOVE LEAD FROM 240 TERMINAL AND CONNECT IT TO 208. CAP ALL UNUSED TERMINALS.
- UPM-1 INCLUDES BUILT IN: 270-300 SECOND RANDOM START
300 SECOND DELAY ON BREAK
120 SECOND LOW PRESSURE BYPASS
- "TEST" DIP SWITCH REDUCES DELAYS TO 10 SEC WHEN SET TO YES. MUST BE SET TO "NO" FOR NORMAL OPERATION.
- "FREEZE SENSOR" ON CONDENSER WILL OPERATE AT 26 F BY DEFAULT, IF 15 F OPERATION IS REQUIRED JUMPER R30 MUST BE CUT. IF FREEZE SENSOR IS NOT INSTALLED A JUMPER SHALL BE INSTALLED BETWEEN THE FREEZE1 OR FREEZE2 SENSOR TERMINALS.
- "ALARM OUTPUT" DIP SWITCH MUST BE SET TO "PULSE" IF BLINKING T-STAT SERVICE LIGHT IS DESIRED.
- DEFAULT SETTINGS FOR UPM BOARD FROM FACTORY SHOWN.
- ALARM OUTPUT IS NORMALLY OPEN (NO) DRY CONTACT. IF 24 VAC IS NEEDED, CONNECT R TO ALR-COM TERMINAL. 24 VAC WILL BE SENSED ON THE ALR-OUT WHEN THE UNIT IS IN ALARM CONDITION. OUTPUT WILL BE PULSED IF PULSE IS SELECTED.
- TERMINAL BLOCK TB3 LOCATED INSIDE DISCONNECT SWITCH BOX.
- CHECK FOR PROPER PHASE ROTATION ON UNITS WITH SCROLL COMPRESSORS. REVERSE ROTATION WILL DAMAGE THE COMPRESSOR AND VOID UNIT WARRANTY.
- FACTORY-MOUNTED LOOP PUMP OR TWO-WAY WATER VALVE. BOTH DEVICES WILL NOT BE PRESENT IN THE SAME UNIT.
- PUMP MOTOR IS WIRED BETWEEN LINE AND NEUTRAL FOR 380-460VAC UNITS. FOR 208/230VAC UNITS PUMP MOTOR IS WIRED BETWEEN LINES.

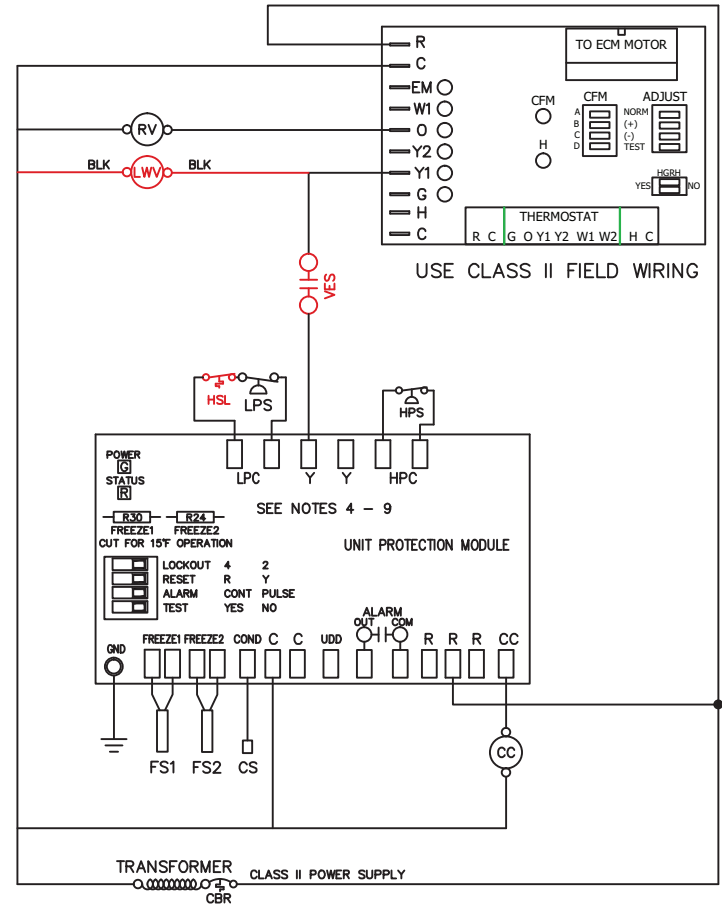
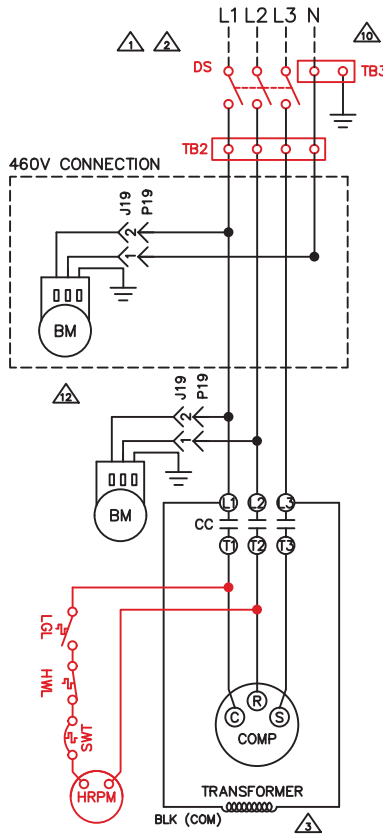

1 STAGE - 3 PHASE - EON MOTOR			
1/2 THROUGH 6 TONS CAPACITY			
UPM I - C			
PART No.	8 733 810 193		
DWG No.	DRAWN BY:	DATE	REV
50PS311002	MLM	06/23/2016	3
E-MAIL:			

Fig. 28 — Constant Airflow Motor, Three Phase/Single Stage, Complete C Control

CAUTION: UNIT CONTAINS TWO POWER SUPPLIES - ENSURE BOTH SUPPLIES ARE OFF BEFORE SERVICING

TRANSFORMER PRIMARY LEAD CLR:	
120	- WHI
208	- RED
240	- ORG
277	- BRN
380	- PUR OR YEL
460	- BLK/RED
575	- GRY

UPM STATUS LED - BLINK CODES	
1	HIGH PRESSURE FAULT
2	LOW PRESSURE FAULT
3	CONDENSER FREEZE CONDITION
4	CONDENSATE OVERFLOW FAULT
5	BROWN OUT FAULT
6	EVAPORATOR FREEZE CONDITION

FACTORY WIRE _____
FIELD WIRE - - - - -

STANDARD COMPONENTS LEGEND:

- AUX - AUXILIARY RELAY (FOR LOOP PUMP, ETC)
- BCA - BOILERLESS CONTROL AQUASTAT
- BM - BLOWER MOTOR
- COMP - COMPRESSOR
- CBR - 24V CIRCUIT BREAKER
- CC - COMPRESSOR CONTACTOR
- CS - CONDENSATE SENSOR (IN DRAIN PAN)
- EMS - ENERGY MGMT SYSTEM RELAY
- FS - FREEZE SENSOR
- HCR - HEATING/COOLING RELAY
- HPS - HIGH PRESSURE SWITCH
- LED - UNIT STATUS DISPLAY
- LP - LOOP PUMP (FIELD INSTALLED)
- LPS - LOW PRESSURE SWITCH
- PM - PHASE MONITOR
- RV - REVERSING VALVE (HEAT PUMPS)

OPTIONAL COMPONENTS LEGEND:

- [] DS - DISCONNECT SWITCH
- [] HGV - HOT GAS VALVE SOLENOID
- [] HRP - HEAT RECOVERY PACKAGE
- [] HRP - HEAT RECOVERY PUMP
- [] LGL - LOW GAS TEMPERATURE LIMIT
- [] HWL - HOT WATER LIMIT
- [] SWT - ON/OFF SWITCH OVERLOAD PROTECTION
- [] HSL - HIGH TEMPERATURE SUCTION LIMIT (WITH HOT GAS BYPASS ONLY)
- [] LWV - LEAVING WATER VALVE
- [] TB2 - MAIN TERMINAL BLOCK (460V UNITS ONLY)
- [] TB3 - TERMINAL BLOCK DISCONNECT SWITCH
- [] YES - VALVE END SWITCH

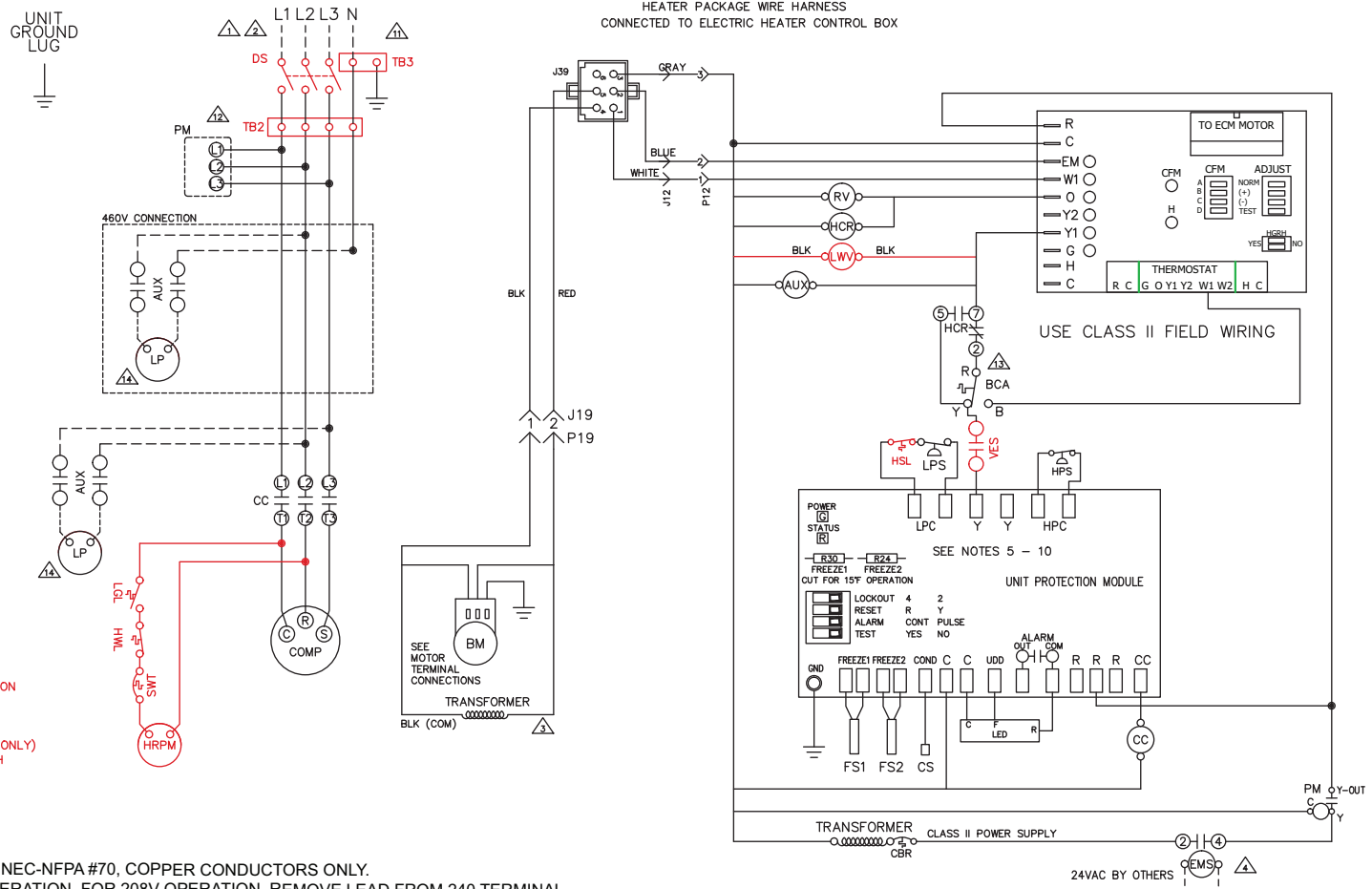

- NOTES:**
- SEE UNIT NAMEPLATE FOR ELECTRICAL RATING.
 - ALL FIELD WIRING MUST BE IN ACCORDANCE WITH NEC-NFPA #70, COPPER CONDUCTORS ONLY.
 - 208/230V UNITS ARE FACTORY WIRED FOR 230V OPERATION. FOR 208V OPERATION, REMOVE LEAD FROM 240 TERMINAL AND CONNECT IT TO 208. CAP ALL UNUSED TERMINALS.
 - UPM-1 INCLUDES BUILT IN: 270-300 SECOND RANDOM START
300 SECOND DELAY ON BREAK
120 SECOND LOW PRESSURE BYPASS
 - "TEST" DIP SWITCH REDUCES DELAYS TO 10 SEC WHEN SET TO YES. MUST BE SET TO "NO" FOR NORMAL OPERATION.
 - "FREEZE SENSOR" ON CONDENSER WILL OPERATE AT 26 F BY DEFAULT, IF 15 F OPERATION IS REQUIRED JUMPER R30 MUST BE CUT. IF FREEZE SENSOR IS NOT INSTALLED A JUMPER SHALL BE INSTALLED BETWEEN THE FREEZE1 OR FREEZE2 SENSOR TERMINALS.
 - "ALARM OUTPUT" DIP SWITCH MUST BE SET TO "PULSE" IF BLINKING T-STAT SERVICE LIGHT IS DESIRED.
 - DEFAULT SETTINGS FOR UPM BOARD FROM FACTORY SHOWN.
 - ALARM OUTPUT IS NORMALLY OPEN (NO) DRY CONTACT. IF 24 VAC IS NEEDED, CONNECT R TO ALR-COM TERMINAL. 24 VAC WILL BE SENSED ON THE ALR-OUT WHEN THE UNIT IS IN ALARM CONDITION. OUTPUT WILL BE PULSED IF PULSE IS SELECTED.
 - TERMINAL BLOCK TB3 LOCATED INSIDE DISCONNECT SWITCH BOX.
 - CHECK FOR PROPER PHASE ROTATION ON UNITS WITH SCROLL COMPRESSORS. REVERSE ROTATION WILL DAMAGE THE COMPRESSOR AND VOID UNIT WARRANTY.
 - FACTORY-MOUNTED LOOP PUMP OR TWO-WAY WATER VALVE. BOTH DEVICES WILL NOT BE PRESENT IN THE SAME UNIT.
 - PUMP MOTOR IS WIRED BETWEEN LINE AND NEUTRAL FOR 380-460VAC UNITS. FOR 208/230VAC UNITS PUMP MOTOR IS WIRED BETWEEN LINES.

1 STAGE - 3 PHASE - EON MOTOR			
1 1/4 THROUGH 6 TONS CAPACITY			
UPM I - D - ELECTRIC HEAT			
PART No.	8 733 810 304		
DWG No.	DRAWN BY:	DATE	REV
50PS311017	MLM	07/14/2016	3
E-MAIL:			

Fig. 29 — Constant Airflow Motor, Three Phase/Single Stage, E-Heat, Deluxe D Control

UPM STATUS LED - BLINK CODES	
1	HIGH PRESSURE FAULT
2	LOW PRESSURE FAULT
3	CONDENSER FREEZE CONDITION
4	CONDENSATE OVERFLOW FAULT
5	BROWNOUT FAULT
6	EVAPORATOR FREEZE CONDITION

TRANSFORMER PRIMARY LEAD CLR:	
120	- WHT
208	- RED
240	- ORG
277	- BRN
380	- PUR OR YEL
460	- BLK/RED
575	- GRV

FACTORY WIRE _____
FIELD WIRE - - - - -

STANDARD COMPONENTS LEGEND:

- AUX - AUXILIARY RELAY (FOR LOOP PUMP, ETC)
- BM - BLOWER MOTOR
- COMP - COMPRESSOR
- CBR - 24V CIRCUIT BREAKER
- CC - COMPRESSOR CONTACTOR
- CS - CONDENSATE SENSOR (IN DRAIN PAN)
- FS - FREEZE SENSOR
- HPS - HIGH PRESSURE SWITCH
- LP - LOOP PUMP
- LED - UNIT STATUS LED
- LPS - LOW PRESSURE SWITCH
- RV - REVERSE VALVE(HEAT PUMPS)

OPTIONAL COMPONENTS LEGEND:

- [] DS - DISCONNECT SWITCH
- [] HSL - HIGH TEMP SUCTION LIMIT (WITH HOT GAS BYPASS ONLY)
- [] LWV - LEAVING WATER VALVE
- [] VES - VALVE END SWITCH
- [] HRP - HEAT RECOVERY PACKAGE, INCLUDES:
HRPM - HEAT RECOVERY PUMP
LGL - LOW GAS TEMP LIMIT
HWL - HOT WATER LIMIT
- [] SWT - ON/OFF SWITCH OVERLOAD PROTECTION
- [] PM - PHASE MONITOR
- [] TB2 - MAIN TERMINAL BLOCK (460V UNITS ONLY)
- [] TB3 - TERMINAL BLOCK DISCONNECT SWITCH (460V UNITS ONLY)

NOTES:

- SEE UNIT NAME PLATE FOR ELECTRICAL RATING.
- ALL FIELD WIRING MUST BE IN ACCORDANCE WITH N.E.C.-N.F.P.A. #70, COPPER CONDUCTORS ONLY - CONDUCTEURS EN CUIVRE SEULEMENT.
- 208/230V UNITS ARE FACTORY WIRED FOR 230V OPERATION. FOR 208V OPERATION, REMOVE LEAD FROM 240 TERMINAL AND CONNECT IT TO 208. CAP ALL UNUSED TERMINALS.
- FOR ALTERNATE EMS COIL VOLTAGES CONSULT FACTORY
- UPM-I INCLUDES BUILT IN: 270-300 SECOND RANDOM START
300 SECOND DELAY ON BREAK
120 SECOND LOW PRESSURE BYPASS
- "TEST" DIP SWITCH REDUCES DELAYS TO 10 SEC WHEN SET TO YES. MUST BE SET TO "NO" FOR NORMAL OPERATION.
- "FREEZE SENSOR" ON CONDENSER WILL OPERATE AT 26°F BY DEFAULT, IF 15°F OPERATION IS REQUIRED JUMPER R30. MUST BE CUT IF FREEZE SENSOR IS NOT INSTALLED A JUMPER SHALL BE INSTALLED BETWEEN THE FREEZE1 OR FREEZE2 SENSOR TERMINALS.
- "ALARM OUTPUT" DIP SWITCH MUST BE SET TO "PULSE" IF BLINKING T-STAT SERVICE LIGHT IS DESIRED.
- DEFAULT SETTINGS FOR UPM BOARD FROM FACTORY SHOWN. ALSO SEE INSTALLATION MANUAL.
- ALARM OUTPUT IS NORMALLY OPEN (NO) DRY CONTACT. IF 24 VAC IS NEEDED, CONNECT R TO ALR-COM TERMINAL, 24VAC WILL BE SENSED ON THE ALR-OUT WHEN THE UNIT IS IN ALARM CONDITION. OUTPUT WILL BE PULSED IF PULSE IS SELECTED.
- TERMINAL BLOCK TB3 LOCATED IN SIDE DISCONNECT SWITCH BOX
- CHECK FOR PROPER PHASE ROTATION ON UNITS WITH SCROLL COMPRESSORS. REVERSE ROTATION WILL DAMAGE THE COMPRESSOR AND VOID UNIT WARRANTY.
- EON MOTOR IS WIRED BETWEEN LINE AND NEUTRAL FOR 380-460VAC UNITS. FOR 208/230VAC UNITS EON MOTOR IS WIRED BETWEEN LINES.

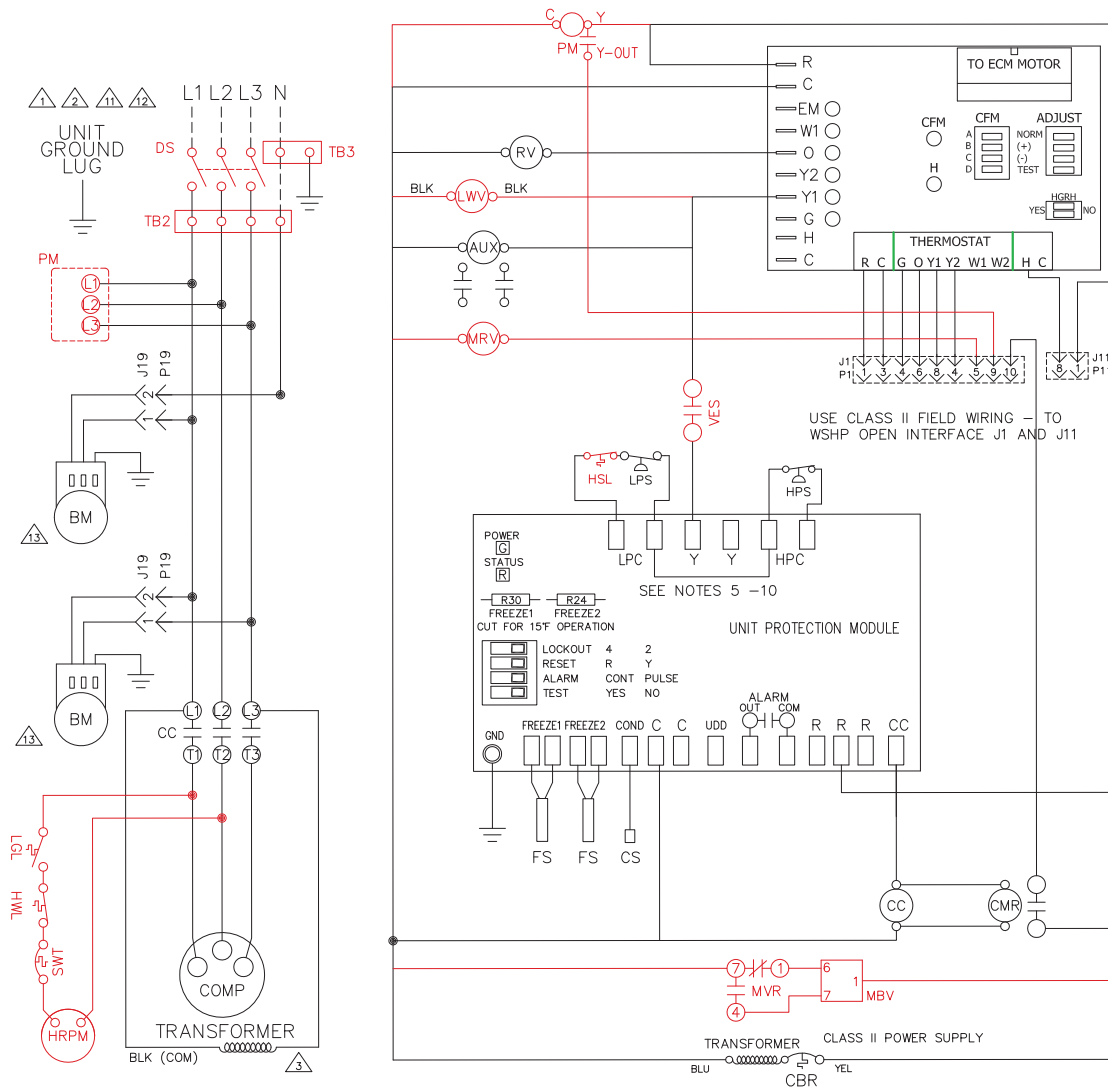
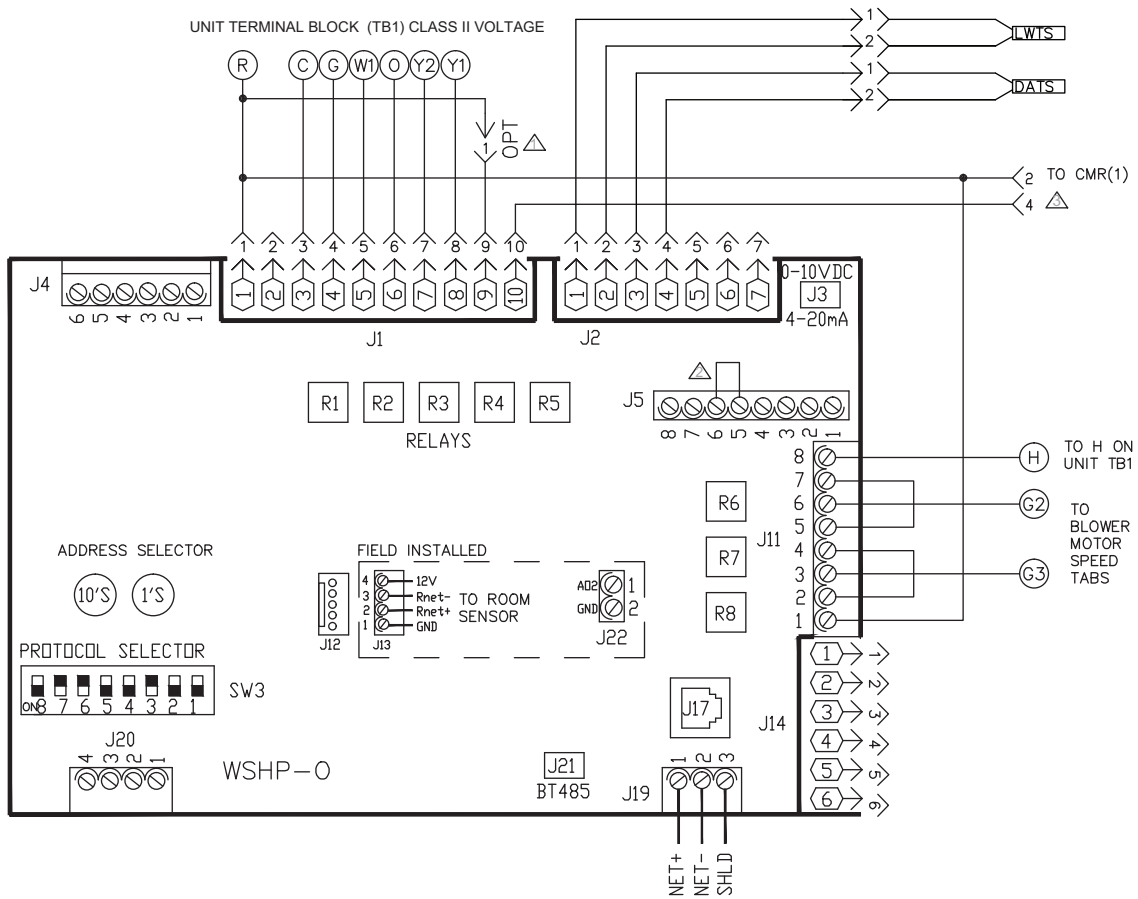

Fig. 30 — Constant Airflow Motor, Three Phase/Single Stage, WSHP Open



- △ J1-9 USED TO CONNECT FIRE ALARM RELAY OR PHASE MONITOR OPTIONS
- △ FACTORY JUMPER IS INSTALLED ON J5-5 AND J5-6 IF CONDENSATE FLOAT SWITCH (NC) IS NOT PRESENT
- △ FOR 2-STAGE UNITS, CONNECT CMR CONN ACROSS PINS 4 AND 6 OF CMR1 WITH SIGNAL CMR-4 GOING TO PIN 4 AND SIGNAL CMR-2 GOING TO PIN 6.
- ← → OPTIONAL WIRING
- STANDARD COMPONENTS:
- DATS - DISCHARGE AIR TEMP SENSOR
- LWTS - LEAVING WATER TEMP SENSOR

Fig. 31 — WSHP Open DDC Wiring Diagram

**CAUTION: UNIT CONTAINS TWO POWER SUPPLIES -
MAKE SURE BOTH ARE OFF BEFORE SERVICING.**

HEATER PACKAGE WIRE HARNESS PLUG
CONNECTED TO MAIN CONTROL BOX
NOTE: L1 AND L2 PROVIDE POWER TO
CONTROL TRANSFORMER AND BLOWER MOTOR

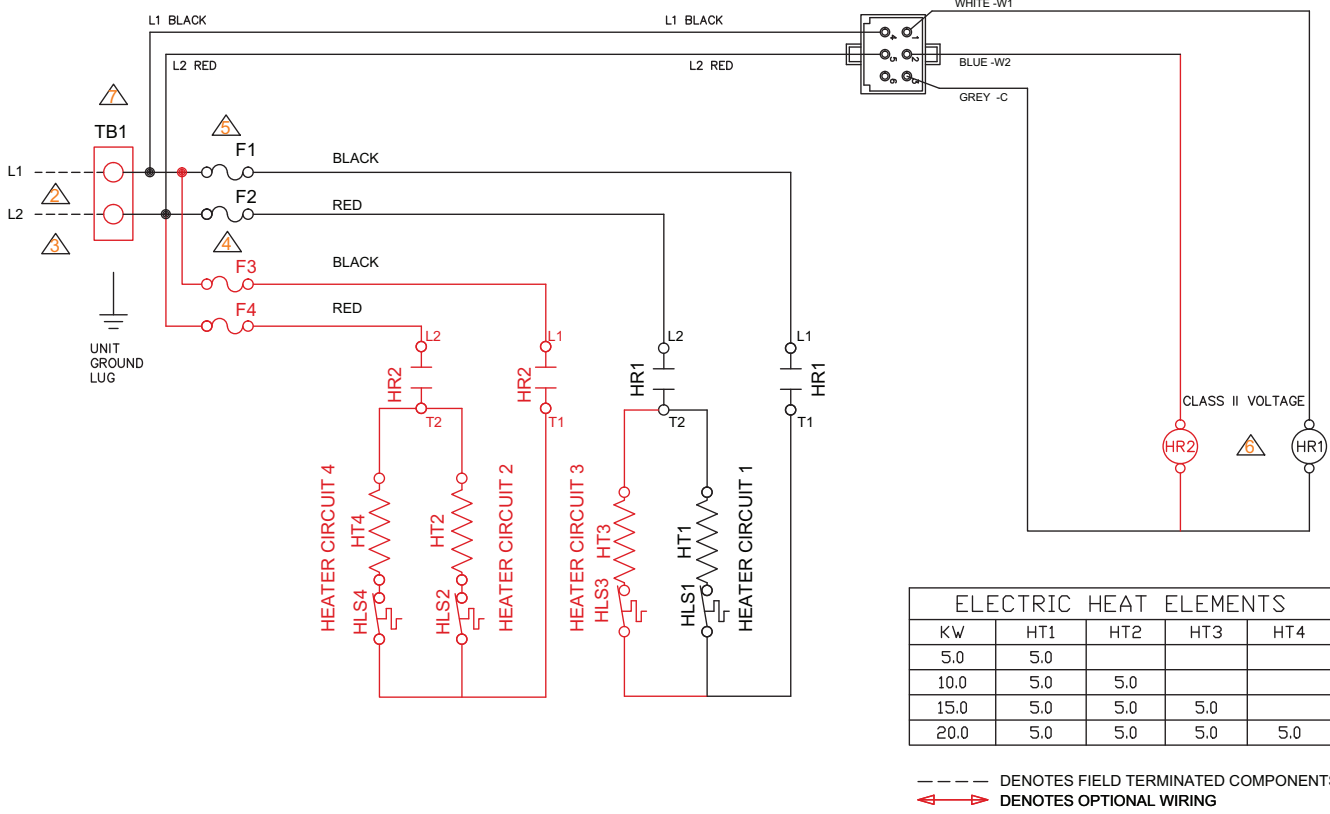

STANDARD COMPONENTS LEGEND

- HLS** — High Temp Limit Switch
- HT1** — Heater Element 1
- HR1** — Heater Contactor 1

OPTIONAL COMPONENTS LEGEND

- [] **F1-4** — Fuses (1-4)
- [] **HR2** — Heater Contactor 2
- [] **HT2-4** — Heater Element (2-4)
- [] **TB1** — Power Terminal Block

NOTES:

1. See unit name plate for electrical rating.
2. All field wiring must be in accordance with NEC-NFPA #70. Use copper conductors only - **Conducteurs en cuivre seulement.**
3. 208/230-v units are factory wired for 230-v operation. For 208-v operation, remove lead from 240 terminal and connect it to 208 labeled terminal. Cap all unused terminals.
4. Only heaters 15 - 20 kW are fused.
5. Units equipped with fuses use one-time class K5 fuses rated at 250VAC 30A for 15kW and 60A for 20kW heater packages.
6. Thermostats using W2/E as emergency heat signal must terminate blue W2 wire on HR1 coil for 5kW units.
7. Terminal block used on 5kW/10kW units only.

DWG No. HE100001

Fig. 32 — Electrical Heat Wiring Diagram

Table 4 — Standard Motor — PSC for 007-012, Constant Torque for 015-070 Motor Electrical Data

50PS UNIT SIZE	RATED VOLTAGE v-ph-Hz	COMPRESSOR			BLOWER MOTOR			MIN. CIRCUIT AMP	MAX FUSE
		Qty	RLA	LRA	Qty	FLA	HP		
007	280/230-1-60	1	2.5	17.7	1	0.96	0.10	4.1	15
	265-1-60	1	2.6	13.5	1	0.85	0.10	4.3	15
009	208/230-1-60	1	3.4	22.2	1	0.96	0.10	5.3	15
	265-1-60	1	2.9	18.8	1	0.85	0.10	4.6	15
012	115-1-60	1	9.6	58.4	1	2.20	0.10	14.2	20
	208/230-1-60	1	4.6	27.9	1	0.96	0.10	6.8	15
	265-1-60	1	3.8	22.2	1	0.85	0.10	5.8	15
015	208/230-1-60	1	5.6	29.0	1	2.80	0.33	9.8	15
	265-1-60	1	4.6	20.0	1	2.60	0.33	8.4	15
018	208/230-1-60	1	7.4	33.0	1	2.80	0.33	12.1	15
	265-1-60	1	6.0	28.0	1	2.60	0.33	10.1	15
024	208/230-1-60	1	13.5	58.3	1	2.80	0.33	19.7	30
	265-1-60	1	9.0	54.0	1	2.60	0.33	13.9	20
	208/230-3-60	1	7.1	55.4	1	2.80	0.33	11.7	15
	460-3-60	1	3.5	28.0	1	2.10	0.50	6.5	15
030	208/230-1-60	1	12.8	58.3	1	4.10	0.50	20.1	30
	265-1-60	1	9.6	54.0	1	3.60	0.50	15.6	25
	208/230-3-60	1	7.7	55.4	1	2.80	0.50	13.7	20
	460-3-60	1	3.6	28.0	1	2.10	0.50	6.6	15
036	208/230-1-60	1	16.0	77.0	1	6.00	0.75	26.0	40
	208/230-3-60	1	10.0	71.0	1	6.00	0.75	18.5	25
	460-3-60	1	4.7	38.0	1	4.60	0.75	9.1	15
042	208/230-1-60	1	16.7	79.0	1	6.00	0.75	25.3	40
	208/230-3-60	1	10.4	73.0	1	6.00	0.75	19.0	25
	460-3-60	1	5.8	38.0	1	4.60	0.75	10.5	15
048	208/230-1-60	1	19.9	109.0	1	6.00	0.75	30.9	50
	208/230-3-60	1	13.6	83.1	1	6.00	0.75	23.0	35
	460-3-60	1	6.1	41.0	1	4.60	0.75	10.8	15
060	208/230-1-60	1	25.0	134.0	1	7.60	1.00	38.9	60
	208/230-3-60	1	15.9	110.0	1	7.60	1.00	27.5	40
	460-3-60	1	7.1	52.0	1	4.00	1.00	12.9	20
070	208/230-1-60	1	26.3	134.0	1	7.60	1.00	38.5	60
	208/230-3-60	1	15.6	110.0	1	7.60	1.00	27.1	40
	460-3-60	1	7.8	52.0	1	4.00	1.00	13.8	20

LEGEND

- FLA** — Full Load Amps
- LRA** — Locked Rotor Amps
- RLA** — Rated Load Amps

Table 5 — Constant Airflow ECM Motor Electrical Data

50PS UNIT SIZE	RATED VOLTAGE v-ph-Hz ^a	COMPRESSOR			BLOWER MOTOR			MIN. CIRCUIT AMP	MAX FUSE
		Qty	RLA	LRA	Qty	FLA	HP		
015	208/230-1-60	1	5.6	29.0	1	2.8	0.33	9.8	15
	265-1-60	1	4.6	20.0	1	2.6	0.33	8.4	15
018	208/230-1-60	1	7.4	33.0	1	2.8	0.33	12.1	15
	265-1-60	1	6.0	28.0	1	2.6	0.33	10.1	15
024	208/230-1-60	1	13.5	58.3	1	2.8	0.33	19.7	30
	265-1-60	1	9.0	54.0	1	2.6	0.33	13.9	20
	208/230-3-60	1	7.1	55.4	1	2.8	0.33	11.7	15
	460-3-60 ^b	1	3.5	28.0	1	2.6	0.33	7.0	15
030	208/230-1-60	1	12.8	58.3	1	2.8	0.33	18.8	30
	265-1-60	1	9.6	54.0	1	2.6	0.33	14.6	20
	208/230-3-60	1	7.7	55.4	1	2.8	0.33	12.4	20
	460-3-60 ^b	1	3.6	28.0	1	2.6	0.33	7.1	15
036	208/230-1-60	1	16.0	77.0	1	4.3	0.50	24.3	40
	208/230-3-60	1	10.0	71.0	1	4.3	0.50	16.8	25
	460-3-60 ^b	1	4.7	38.0	1	4.1	0.50	10.0	15
042	208/230-1-60	1	15.4	83.9	1	6.8	0.75	26.1	40
	208/230-3-60	1	10.4	73.0	1	6.8	0.75	19.8	30
	460-3-60 ^b	1	5.8	38.0	1	5.5	0.75	12.8	15
048	208/230-1-60	1	19.9	109.0	1	6.8	0.75	31.7	50
	208/230-3-60	1	13.6	83.1	1	6.8	0.75	23.8	35
	460-3-60 ^b	1	6.1	41.0	1	5.5	0.75	13.1	15
060	208/230-1-60	1	25.0	134.0	1	6.8	0.75	38.1	60
	208/230-3-60	1	15.9	110.0	1	6.8	0.75	26.7	40
	460-3-60 ^b	1	7.1	52.0	1	5.5	0.75	14.4	20
070	208/230-1-60	1	24.7	166.0	1	9.1	1.00	40.0	60
	208/230-3-60	1	15.6	110.0	1	9.1	1.00	28.6	40
	460-3-60 ^b	1	7.8	52.0	1	6.9	1.00	16.7	20

NOTE(S):

- a. 4-Wire design (L1, L2, L3, N) is required on 460V 3-Phase units with Constant Airflow ECM motor.
- b. 460-v unit contains 265-v fan motor and requires a neutral to power motor.

LEGEND

- FLA** — Full Load Amps
- LRA** — Locked Rotor Amps
- RLA** — Rated Load Amps

Table 6 — First Data Plate for Units with EH Option - Compressor Power Connection

MODELS	RATED VOLTAGE	VOLTAGE MIN/MAX	COMPRESSOR			UNIT		
			QTY	RLA	LRA	FLA (AMPS)	MIN CIRCUIT AMPS	MAX FUSE/ HACR
50PS018	208-230/60/1	197/253	1	7.4	33.0	7.4	9.3	15
50PS024	208-230/60/1	197/253	1	13.5	58.3	13.5	16.9	30
	208-230/60/3	197/253	1	7.1	55.4	7.1	8.9	15
50PS030	208-230/60/1	197/253	1	12.8	58.3	12.8	16.0	25
	208-230/60/1	197/253	1	7.7	55.4	7.7	9.6	15
50PS036	208-230/60/1	197/253	1	16.0	77.0	16.0	20.0	35
	208-230/60/1	197/253	1	10.0	71.0	10.0	12.5	25
50PS042	208-230/60/1	197/253	1	15.4	83.9	15.4	19.3	35
	208-230/60/1	197/253	1	10.4	73.0	10.4	13.0	25
50PS048	208-230/60/1	197/253	1	19.9	109.0	19.9	24.9	40
	208-230/60/1	197/253	1	13.6	83.1	13.6	17.0	30
50PS060	208-230/60/1	197/253	1	25.0	134.0	25.0	31.3	55
	208-230/60/1	197/253	1	15.9	110.0	15.9	19.9	35
50PS070	208-230/60/1	197/253	1	24.7	166.0	24.7	30.9	55
	208-230/60/1	197/253	1	15.6	110.0	15.6	19.5	35

Table 7 — Second Data Plate for Units with Electric Heater Option and Constant Torque ECM Motor^{a,b}

UNIT SIZE	EH RATED kW	STAGE	HEATER WATTS		HEATER AMPS		MOTOR FLA (A)	CIRCUIT FUSES	MCA		MOP	
			240	208	240	208			240	208	240	208
018	4.8	1	4,800	3,600	20.0	17.3	2.8	—	28.5	25.1	30	30
024	4.8	1	4,800	3,600	20.0	17.3	2.8	—	28.5	25.1	30	30
	9.6	1	9,600	7,200	40.0	34.6	2.8	—	53.5	46.8	60	50
030	4.8	1	4,800	3,600	20.0	17.3	4.1	—	30.1	26.8	35	30
	9.6	1	9,600	7,200	40.0	34.6	4.1	—	55.1	48.4	60	50
036	4.8	1	4,800	3,600	20.0	17.3	6.0	—	32.5	29.1	35	30
	9.6	1	9,600	7,200	40.0	34.6	6.0	—	57.5	50.8	60	60
	14.4	2	14,400	10,800	60.0	51.9	6.0	F1/F2 F3/F4	82.5	72.4	90	80
042	4.8	1	4,800	3,600	20.0	17.3	6.0	—	32.5	29.1	35	30
	9.6	1	9,600	7,200	40.0	34.6	6.0	—	57.5	50.8	60	60
	14.4	2	14,400	10,800	60.0	51.9	6.0	F1/F2 F3/F4	82.5	72.4	90	80
048	4.8	1	4,800	3,600	20.0	17.3	6.0	—	32.5	29.1	35	30
	9.6	1	9,600	7,200	40.0	34.6	6.0	—	57.5	50.8	60	60
	14.4	2	14,400	10,800	60.0	51.9	6.0	F1/F2 F3/F4	82.5	72.4	90	80
	19.2	2	19,200	14,000	80.0	69.2	6.0	F1/F2 F3/F4	107.5	94.0	110	100
060	4.8	1	4,800	3,600	20.0	17.3	7.6	—	34.5	31.1	35	35
	9.6	1	9,600	7,200	40.0	34.6	7.6	—	59.5	52.8	60	60
	14.4	2	14,400	10,800	60.0	51.9	7.6	F1/F2 F3/F4	84.5	74.4	90	80
	19.2	2	19,200	14,000	80.0	69.2	7.6	F1/F2 F3/F4	109.5	96.0	110	100
070	4.8	1	4,800	3,600	20.0	17.3	7.6	—	34.5	31.1	35	35
	9.6	1	9,600	7,200	40.0	34.6	7.6	—	59.5	52.8	60	60
	14.4	2	14,400	10,800	60.0	51.9	7.6	F1/F2 F3/F4	84.5	74.4	90	80
	19.2	2	19,200	14,000	80.0	69.2	7.6	F1/F2 F3/F4	109.5	96.0	110	100

NOTE(S):

- a. Units with Factory Installed Electric Heat option will have two separate data plates for each electrical circuit.
- b. Electric heat is not available for horizontal-straight through airflow configuration.

LEGEND

- EH — Electric Heat
- FLA — Full Load Amps
- MCA — Minimum Circuit Amps
- MOP — Maximum Overcurrent Protection



Table 8 — Second Data Plate for Units with Electric Heater Option and Constant Airflow ECM Motor^{a,b,c}

UNIT SIZE	EH RATED KW	STAGE	HEATER WATTS		HEATER AMPS		MOTOR FLA (A)	CIRCUIT FUSES	MCA		MOP	
			240	208	240	208			240	208	240	208
018	4.8	1	4,800	3,600	20.0	17.3	2.8	—	28.5	25.1	30	30
024	4.8	1	4,800	3,600	20.0	17.3	2.8	—	28.5	25.1	30	30
	9.6	1	9,600	7,200	40.0	34.6	2.8	—	53.5	46.8	60	50
030	4.8	1	4,800	3,600	20.0	17.3	2.8	—	28.5	25.1	30	30
	9.6	1	9,600	7,200	40.0	34.6	2.8	—	53.5	46.8	60	50
036	4.8	1	4,800	3,600	20.0	17.3	4.3	—	30.4	27.0	35	30
	9.6	1	9,600	7,200	40.0	34.6	4.3	—	55.4	48.6	60	50
	14.4	2	14,000	10,800	60.0	51.9	4.3	F1/F2 F3/F4	80.4	70.3	90	80
042	4.8	1	4,800	3,600	20.0	17.3	6.8	—	33.5	30.1	35	35
	9.6	1	9,600	7,200	40.0	34.6	6.8	—	58.5	51.8	60	60
	14.4	2	14,400	10,800	60.0	51.9	6.8	F1/F2 F3/F4	83.5	73.4	90	80
048	4.8	1	4,800	3,600	20.0	17.3	6.8	—	33.5	30.1	35	35
	9.6	1	9,600	7,200	40.0	34.6	6.8	—	58.5	51.8	60	60
	14.4	2	14,400	10,800	60.0	51.9	6.8	F1/F2	83.5	73.4	90	80
								F3/F4				
19.2	2	19,200	14,000	80.0	69.2	6.8	F1/F2 F3/F4	108.5	95.0	110	100	
060	4.8	1	4,800	3,600	20.0	17.3	6.8	—	33.5	30.1	35	35
	9.6	1	9,600	7,200	40.0	34.6	6.8	—	58.5	51.8	60	60
	14.4	2	14,400	10,800	60.0	51.9	6.8	F1/F2	83.5	73.4	90	80
								F3/F4				
19.2	2	19,200	14,000	80.0	69.2	6.8	F1/F2 F3/F4	108.5	95.0	110	100	
070	4.8	1	4,800	3,600	20.0	17.3	9.1	—	36.4	33.0	35	35
	9.6	1	9,600	7,200	40.0	34.6	9.1	—	61.4	54.6	70	60
	14.4	2	14,400	10,800	60.0	51.9	9.1	F1/F2	86.4	76.3	90	80
								F3/F4				
19.2	2	19,200	14,000	80.0	69.2	9.1	F1/F2 F3/F4	111.4	97.9	120	100	

NOTE(S):

- a. Units with Factory Installed Electric Heat option will have two separate data plates for each electrical circuit.
- b. Electric heat is not available for horizontal-straight through airflow configuration.
- c. 4-wire design (L1, L2, L3, N) is required on 460V 3-Phase units with Constant Airflow ECM motor.

LEGEND

- EH — Electric Heat
- FLA — Full Load Amps
- MCA — Minimum Circuit Amps
- MOP — Maximum Overcurrent Protection



Step 9 — Wire Control Connections

COMPLETE C AND DELUXE D CONTROL

Control wiring for units with PSC and Constant Torque blower motors are connected to a terminal block located in the unit electrical box. Refer to the unit wiring diagram for connection details.

⚠ WARNING

To avoid possible injury or death due to electrical shock, open the power supply disconnect switch and secure it in an open position during installation.

⚠ CAUTION

Never route control wiring through the same conduit as power supply wiring. Electrical noise and transients from the power wiring can cause communication issues or damage to the control wiring and connected control components.

Units with Complete C or Deluxe D control packages can be controlled using the included thermostat inputs (R, O, Y1, C, G) for single stage heat pump thermostat or field-installed DDC (Direct Digital Controls) controls. Note that the reversing valve on the unit is energized when the unit is in the cooling mode. See Fig. 33 for typical thermostat connections.

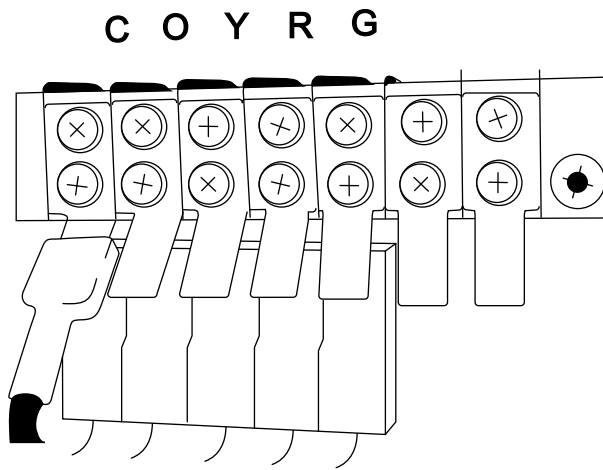

Fig. 33 — Typical Thermostat Connections

Control wiring for units with constant airflow ECM blower motors is routed through a constant airflow ECM interface board. Thermostat input wiring is connected to the 10-pin screw type terminal block on the lower center portion of the ECM Interface Board. In addition to providing a connecting point for thermostat wiring, the interface board also translates thermostat inputs into control commands for the Electronic Commutated Motor (ECM) DC fan motor and displays an LED indication of operating status. Refer to the unit wiring diagrams for complete details. See Fig. 34. The thermostat connections and their functions are as follows:

ECM INTERFACE THERMOSTAT CONNECTIONS

- **Y1** First Stage Compressor Operation
- **Y2** Second Stage Compressor Operation
- **G** Fan
- **O** Reversing Valve (energized in cooling)
- **W1** Auxiliary Electric Heat (runs with compressor)
- **EM/W2** Emergency Heat (electric heat only)
- **NC** Transformer 24 VAC Common (extra connection)
- **C1** Transformer 24 VAC Common (primary connection)
- **R** Transformer 24 VAC Hot
- **H** Dehumidification Mode

THERMOSTAT AND DDC SENSORS

Thermostats or DDC space sensors should be located on an interior wall away from supply ducts. Avoid locations subject to direct sunlight or drafts, or external walls. Thermostat wiring should be 18 AWG (American Wire Gauge). Refer to the installation instructions for the thermostat for further details.

IMPORTANT: Exceptionally long runs of thermostat wire should be avoided to prevent voltage drops in the control circuit.

HOT GAS REHEAT CONTROL

Units with hot gas reheat (HGRH) will include an additional H terminal on the input terminal board for dehumidification control. To enable a call for dehumidification, a 24V signal must be sent to the H terminal with no voltage applied to the Y1 or O terminals. Any call for cooling (Y1 and O) will override the dehumidification call.

AUXILIARY RELAY (DELUXE D ONLY)

All units with Deluxe D control include an auxiliary relay that can be field wired to enable a field provided loop pump or solenoid valve when there is a call for compressor operation. See Fig. 17.

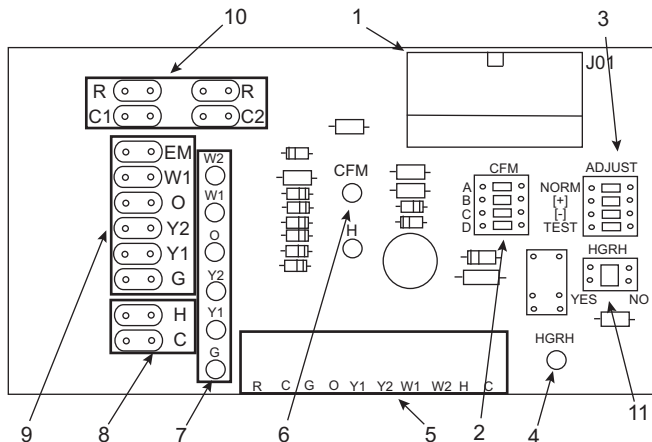

LEGEND

- 1 Motor harness plug
- 2 Blower CFM adjustment
- 3 Motor settings
- 4 Dehumidification indication
- 5 Thermostat digital contact inputs
- 6 CFM count indicator
- 7 Thermostat input status indication
- 8 Reheat digital outputs
- 9 Thermostat outputs
- 10 24 VAC
- 11 Dehumidification method selector

Fig. 34 — ECM Interface Board Physical Layout

ENERGY MANAGEMENT SWITCH (DELUXE D ONLY)

All units with Deluxe D control include an energy management switch (EMS) relay that can be field wired to disable unit operation when a 24V signal is removed from the relay. Removing the 24V signal causes the relay to open, which cuts 24V power to the unit control circuit. All unit components will be disabled when the EMS is deactivated. See Fig. 17.

NOTE: Units with constant torque ECM motors may experience a 30 second delay between when the EMS is activated and when the blower finally shuts off. Constant torque ECM blowers are factory programmed with a 30 second delay when losing the control signal, to prevent nuisance shut downs.

BOILERLESS HEAT CONTROL (DELUXE D ONLY)

All units with Deluxe D control include a boilerless heat relay that can be field wired to enable an external heat source when the water loop temperature drops below the boilerless heat control set point. See Fig. 17.

ALARM OUTPUT (ALL UNITS)

If the unit is being connected to a thermostat or DDC control with an alarm indicator, this connection is made at the unit malfunction output on the Unit Protection Module (UPM). See the Unit Protection Module heading in the Set Up Unit Controls section for further details.

WSHP OPEN CONTROL

WSHP Open is a factory installed DDC control that requires the use of Carrier ZS or WS sensors or the Carrier Equipment Touch or System Touch for space temperature sensing. WSHP Open is not compatible with thermostats or third party temperature sensors.

All WSHP Open wiring is completed at the WSHP Open control board. See Fig. 31 for details. For further instructions on WSHP Open, please visit HVACPartners.com or Carrier.com for the WSHP Open V4 Integration Guide and Points/Properties Guide.

CONTROL TRANSFORMER

⚠ CAUTION

Exceeding the transformer capacity can result in low control voltage, erratic unit operation or damage to the heat pump.

All units include a 75VA transformer. The VA capacity of the transformer should be considered when applying low voltage accessories, such as shut off valves, thermostats, or DDC controls. Table 9 shows the VA draw of typical factory-mounted components in the low voltage heat pump. The total VA draw of the heat pump internal components plus any attached accessories must be lower than the VA capacity of the unit control transformer.

Step 10 — Configure Unit Control Components

⚠ WARNING

To avoid possible injury or death due to electrical shock, open the power supply disconnect switch and secure it in an open position during installation.

UNIT PROTECTION MODULE (UPM)

All units with Complete C, Deluxe D, or WSHP Open are factory provided with a unit protection module. This UPM controls the compressor and has built-in safeties. See Fig. 35.

Freeze Sensor

The default setting for the freeze limit trip is 26°F for applications without anti-freeze. This can be changed to 15°F for applications with anti-freeze by cutting the R30 resistor located on top of the DIP switch SW1.

⚠ CAUTION

If unit is employing a fresh water system (no anti-freeze protection), it is extremely important to have the Freeze1 R30 resistor set to 26°F in order to shut down the unit at the appropriate leaving-water temperature and protect your heat pump from freezing if a freeze sensor is included.

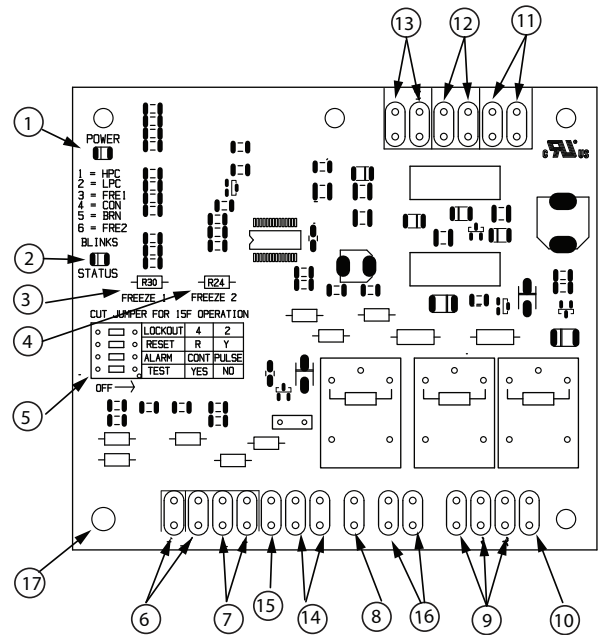

1	Board Power Indicator
2	UPM Status LED Indicator
3	Water Coil Freeze Protection Temperature Selection [R30]
4	Air Coil Freeze Protection Temperature Selection
5	UPM Settings
6	Water Coil Freeze Connection
7	Air Coil Freeze Connection
8	LED Status-Diagnostic Connection
9	24VAC Power Input
10	Compressor Contact Output
11	High Pressure Switch Connection
12	Call for Compressor Y1
13	Low Pressure Switch Connection
14	24VAC Power Common
15	Condensate Overflow Sensor
16	Dry Contact
17	UPM Ground Standoff

Fig. 35 — Unit Protection Module (UPM)

Table 9 — Low Voltage VA Draw

STANDARD CONSTRUCTION		HOT GAS REHEAT OR ECONOMIZER		OPTIONAL COMPONENTS	
Component	VA	Component	VA	Component	VA
Blower Relay (PSC Motors Only)	6-7	Total from 'Standard'	22-26	Monitor Relay (VA draw per relay)	6-7
Reversing Valve Solenoid	8-9	Additional Control Relays	12-14	Internal 2 Way Motorized Valve	7
Compressor Contactor	6-8	Hot Gas Reheat Solenoid	8-9		
UPM Board	2	—	—		
Total VA Draw	22-26	Total VA draw	42-49		

UPM Dip Switch Settings

The DIP switches are used to configure most of the available features of the UPM as follows:

- Lockout mode: two (2) or four (4) strikes
- Reset mode: Y signal or R signal
- Alarm mode: Constant or Pulse
- Test mode: Normal or Test operation

Figure 36 shows the factory default settings for most heat pump applications. However, the unit wiring diagram is the ultimate guide for factory DIP switch default settings. See the Unit Protection Module section in the Troubleshooting section for further details.

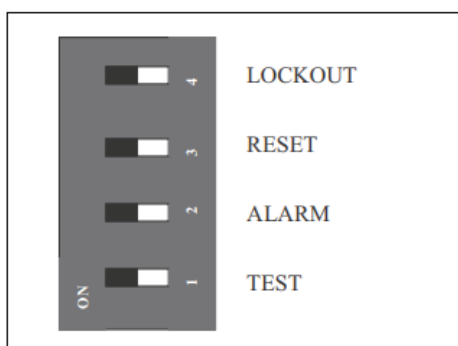

Fig. 36 — Typical DIP Switch Factory Defaults

Table 10 below shows the available options on the UPM board DIP switch banks.

Table 10 — UPM DIP Switch Options

SWITCH NUMBER	DIP SWITCH	ON	OFF
4	LOCKOUT	4	2
3	RESET	R	Y
2	ALARM	CONT	PULSE
1	TEST	YES	NO

⚠ CAUTION

Operation of unit in test mode can lead to accelerated wear and premature failure of components. The "TEST" switch must be set back to "NO" after troubleshooting/servicing.

Alarm Output

Alarm output is normally open (NO) dry contact. If pulse is selected the alarm output will be pulsed. The fault output will depend on

the DIP switch setting for ALARM. If it is set to CONST, a constant signal will be produced to indicate a fault has occurred and the unit requires inspection to determine the type of fault. If it is set to PULSE, a pulse signal is produced and a fault code is detected by a remote device indicating the fault. The remote device must have a malfunction detection capability when the UPM board is set to PULSE.

IMPORTANT: If 24 VAC output is needed R must be wired to ALR-COM terminal; 24 VAC will be available to the ALR-OUT terminal when the unit is in the alarm condition.

WATERSIDE ECONOMIZER (ETO)

When the waterside economizer option is built with the Complete C or Deluxe D controls, it will include an aquastat for economizer control. The aquastat can be adjusted between 20°F and 60°F. When the water loop temperature is below the aquastat set point, the economizer is enabled. The recommended aquastat set point is 55°F. See Fig. 37.

BOILERLESS HEAT CONTROL (DELUXE D ONLY)

All units with Deluxe D control include an aquastat for boilerless heat control. The aquastat can be adjusted between 20°F and 60°F. When the water loop temperature is below the aquastat set point, the heat pump heating is disabled and a field provided auxiliary heat can be enabled. The recommended aquastat set point is 55°F. See Fig. 37.

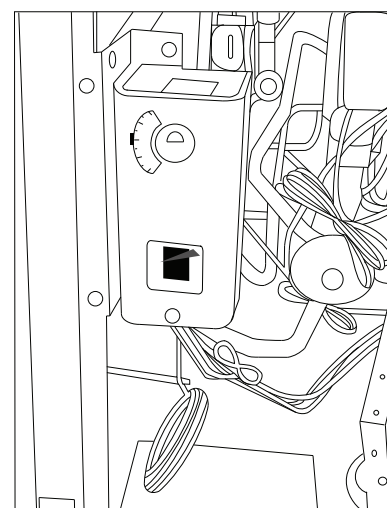

Fig. 37 — Aquastat for Waterside Economizer and Boilerless Control

PRE-START-UP

System Checkout

After completing the installation and before energizing unit, the following system checks should be made prior to initial start-up:

1. Verify that the supply voltage to the heat pump is in accordance with the nameplate ratings.
2. Verify that the control transformer is set to the correct voltage for 208/230V units (factory setting is 230V).
3. Make sure that all electrical connections are tight and secure.
4. Check electrical fusing/breaker and wiring for correct size.
5. Verify that the low voltage wiring between the thermostat or DDC controls and the unit is correct.
6. Verify that the water piping is complete and correct.
7. Verify that there are no leaks in the external piping or in the internal unit piping. Correct as necessary.
8. Verify that the isolation or flow control valves are open and that any automatic flow control valve or balancing valve are set to the correct setting.
9. Check that the water flow is correct and adjust if necessary.
10. Check the blower for free rotation, and that it is secured to the shaft.
11. Verify that the foam blower shipping support has been removed.
12. Vertical Units Only - Verify that vibration isolation has been provided and that the unit has been installed on a solid structure.
13. Horizontal Units Only - Verify that the hanging brackets have been installed and that the unit is secured to an adequate support structure.
14. Verify that the unit has proper service clearance. Be certain that all access panels are secured in place.
15. Verify that ductwork has been properly fastened to supply and return duct collars.
16. Verify that the ductwork is free from obstruction and that all dampers or registers are open.
17. Make sure return air filters are positioned correctly in the filter rack if removed during installation.
18. Verify that the unit is not in TEST mode.
19. Verify that all control components have been properly configured and that all control components have been wired.
20. For units with WSHP Open, verify that a ZS sensor, WS sensor, Equipment Touch, or System Touch has been installed and that a commissioning interface is available.

CLEAN AIR COIL

To obtain maximum performance, clean the air coil before starting the unit. A ten percent solution of dishwasher detergent and water is recommended for both sides of the coil. Rinse thoroughly with water.

Set Blower Motor Speed

PERMANENT SPLIT CAPACITOR (PSC) MOTOR

The 50PS units sizes 07-12 are provided with PSC blower motors with three speed settings. See Table 11 for blower performance by speed setting.

If a motor speed change is required, follow the instructions below:

1. Disconnect power to the heat pump and follow all proper lockout and tagout procedures to ensure that power is removed from the unit.
2. Remove the front access cover.
3. Remove the blower speed wire from the blower relay. Clip the 1/4 in. quick connect from the lead and cap the unused lead.

4. Uncap the desired blower speed wire and terminate with 1/4 in. quick connect. Connect to the blower relay.
5. If the motor is a 460 V motor and the speed is changed from high to medium or low, connect the high speed motor lead to the orange intermediate winding lead instead of simply capping it.

CONSTANT TORQUE (ECM) MOTOR

The 50PS units from size 015 to 070 in 208V, 230V, 265V, or 460V are available with constant torque ECM blower motors. Constant Torque ECM motors have three speed settings. See Table 11 for blower performance by speed setting.

If a motor speed change is required, follow the instructions below:

1. Disconnect power to the heat pump and follow all proper lockout and tagout procedures to ensure that power is removed from the unit.
2. Remove the blower access panel and access the torque tap wire on the motor.
3. Change the torque tap wire to on the molex plug to one of the five speed settings. See Fig. 38.

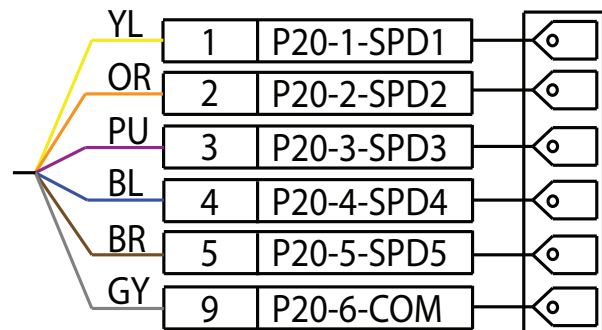

Fig. 38 — Constant Torque ECM Pin Diagram

NOTE: Constant Torque Motors (ECM) are programmed to have a 30s ramp up/down. Contact application engineering for details on applications where immediate ramp down is required.

CONSTANT AIRFLOW (ECM) MOTOR

The 50PS units from size 015 to 070 in 208V, 230V, 265V, or 460V are available with a constant airflow ECM blower motor. These motors dynamically adjust their power output to precisely match the desired airflow on a pre-programmed fan curve. See Table 12 for Constant Airflow ECM Motor Blower performance data. These motors include the following features:

1. **Three Speed Settings:** Units are factory set to "NORM" but can be field adjusted to "+" to increase CFM by 15% or to "-" to reduce CFM by 15%. See the constant airflow ECM motor blower performance table for complete details on available CFM for each unit size (refer to the Wire Control Connections section of this manual).
2. **Low CFM Ventilation:** Units circulate air at 70% of full airflow rate when there is a call for fan only.
3. **Passive Dehumidification:** Reduces airflow during a cooling call when dehumidification is also required. This reduces the sensible heat ratio of the cooling coil and extends cooling run time to dehumidify more effectively (refer to the Wire Control Connections section of this manual).
4. **Test Mode:** Operates the motor at a 70% torque setting. This setting can be used to diagnose programming problems in the motor itself (refer to the Wire Control Connections section of this manual).
5. **CFM Indicator Light:** indicator light blinks for each 100 CFM of air delivered.

NOTE: This blink code is approximate and should not replace test and balance.

Table 11 — 50PS Blower Performance, Standard Motor - PSC for 007-012, Constant Torque ECM for 015-070

50PS MODEL SIZE	TAP #	MOTOR SPEED	DEFAULT FACTORY SETTING	AVAILABLE EXTERNAL STATIC PRESSURE (INCHES OF WATER COLUMN)											
				0.1	0.2	0.3	0.4	0.5	0.6	0.7	0.8	0.9	1	1.1	1.2
007	3	High	LOW	430	420	390	360	335	310	260	—	—	—	—	—
	2	Medium		420	390	365	335	310	270	—	—	—	—	—	—
	1	Low		370	360	340	315	285	245	—	—	—	—	—	—
009	3	High	MED	430	420	390	360	335	310	260	—	—	—	—	—
	2	Medium		420	390	365	335	310	270	—	—	—	—	—	—
	1	Low		370	360	340	315	285	245	—	—	—	—	—	—
012	3	High	HI	450	435	415	400	385	360	330	305	—	—	—	—
	2	Medium		425	405	385	375	360	335	310	—	—	—	—	—
	1	Low		390	380	365	350	335	315	290	—	—	—	—	—
015	3	High	MED/2	710	685	650	610	575	545	460	370	—	—	—	—
	2	Medium		530	510	480	445	405	360	—	—	—	—	—	—
	1	Low		430	410	370	335	290	245	—	—	—	—	—	—
018	3	High	MED/2	808	795	768	736	703	658	576	495	—	—	—	—
	2	Medium		615	575	540	500	460	420	—	—	—	—	—	—
	1	Low		540	510	480	445	405	360	—	—	—	—	—	—
024	3	High	MED/2	975	945	910	880	855	825	790	750	—	—	—	—
	2	Medium		905	885	855	825	790	755	700	650	—	—	—	—
	1	Low		725	700	670	640	585	530	—	—	—	—	—	—
030	3	High	MED/2	1225	1195	1170	1140	1110	1075	1010	940	745	—	—	—
	2	Medium		1110	1075	1045	1015	985	955	915	880	700	—	—	—
	1	Low		955	925	890	860	825	790	750	715	685	—	—	—
036	3	High	MED/2	1440	1420	1400	1380	1345	1315	1240	1165	1005	845	—	—
	2	Medium		1340	1315	1290	1270	1245	1225	1180	1135	990	845	—	—
	1	Low		1190	1165	1140	1115	1090	1065	1040	1020	915	810	—	—
042	3	High	MED/2	1645	1635	1610	1585	1560	1535	1510	1485	1460	1430	—	—
	2	Medium		1455	1425	1400	1375	1345	1320	1290	1260	1225	1190	—	—
	1	Low		1220	1190	1160	1130	1100	1070	1015	955	895	830	—	—
048	3	High	MED/2	1840	1820	1795	1775	1745	1720	1695	1670	1645	1615	—	—
	2	Medium		1655	1635	1610	1585	1560	1535	1510	1485	1460	1430	—	—
	1	Low		1455	1425	1400	1375	1345	1320	1290	1260	1225	1190	—	—
060	3	High	MED/2	2225	2195	2165	2135	2105	2075	2045	2015	1980	1945	1900	1850
	2	Medium		2070	2045	2015	1990	1960	1925	1895	1870	1840	1810	1685	1600
	1	Low		1815	1785	1755	1725	1695	1665	1630	1595	1555	1515	1425	—
070	3	High	MED/2	2560	2520	2480	2440	2400	2360	2320	2275	2245	2210	2150	2050
	2	Medium		2440	2400	2360	2320	2280	2245	2200	2155	2120	2085	2000	1900
	1	Low		1920	1880	1835	1795	1745	1695	1655	1615	1570	1520	1425	—

Table 12 — 50PS Blower Performance Constant Airflow ECM^{a,b}

50PS MODEL SIZE	MOTOR SPEED	DEFAULT FACTORY SETTING	AVAILABLE EXTERNAL STATIC PRESSURE (INCHES OF WATER COLUMN)												
			0.1	0.2	0.3	0.4	0.5	0.6	0.7	0.8	0.9	1	1.1	1.2	
015	+	A - Normal	575	575	575	575	575	575	575	575	575	—	—	—	—
	Normal		500	500	500	500	500	500	500	500	500	—	—	—	—
	—		425	425	425	425	425	425	425	425	425	—	—	—	—
018	+	B - Normal	745	745	745	745	745	745	745	745	745	—	—	—	—
	Normal		650	650	650	650	650	650	650	650	650	—	—	—	—
	—		555	555	555	555	555	555	555	555	555	—	—	—	—
024	+	A - Normal	1095	1095	1095	1095	1095	1095	1095	1095	1095	1095	—	—	—
	Normal		950	950	950	950	950	950	950	950	950	950	—	—	—
	—		810	810	810	810	810	810	810	810	810	810	—	—	—
030	+	A - Normal	1150	1150	1150	1150	1150	1150	1150	1150	1150	1150	—	—	—
	Normal		1000	1000	1000	1000	1000	1000	1000	1000	1000	1000	—	—	—
	—		850	850	850	850	850	850	850	850	850	850	—	—	—
036	+	B - Normal	1380	1380	1380	1380	1380	1380	1380	1380	1380	1380	1380	—	—
	Normal		1200	1200	1200	1200	1200	1200	1200	1200	1200	1200	1200	—	—
	—		1020	1020	1020	1020	1020	1020	1020	1020	1020	1020	1020	—	—
042	+	C - Normal	1610	1610	1610	1610	1610	1610	1610	1610	1610	1610	1610	—	—
	Normal		1400	1400	1400	1400	1400	1400	1400	1400	1400	1400	1400	—	—
	—		1190	1190	1190	1190	1190	1190	1190	1190	1190	1190	1190	—	—
048	+	D - Normal	1840	1840	1840	1840	1840	1840	1840	1840	1840	1840	1840	—	—
	Normal		1600	1600	1600	1600	1600	1600	1600	1600	1600	1600	1600	—	—
	—		1360	1360	1360	1360	1360	1360	1360	1360	1360	1360	1360	—	—
060	+	B - Normal	2300	2300	2300	2300	2300	2300	2300	2300	2300	2300	2300	2300	2300
	Normal		2000	2000	2000	2000	2000	2000	2000	2000	2000	2000	2000	2000	2000
	—		1700	1700	1700	1700	1700	1700	1700	1700	1700	1700	1700	1700	—
070	+	A - Normal	2415	2415	2415	2415	2415	2415	2415	2415	2415	2415	2415	2415	2415
	Normal		2100	2100	2100	2100	2100	2100	2100	2100	2100	2100	2100	2100	2100
	—		1785	1785	1785	1785	1785	1785	1785	1785	1785	1785	1785	1785	—

NOTE(S):

- a. Air flow is 70% of tabulated values during fan only operation.
- b. Air flow is 85% of tabulated values during passive dehumidification mode when enabled.

System Flushing and Filling

Once the piping is complete, units require final purging and loop charging. A flush cart pump of at least 1.5 hp is needed to achieve adequate flow velocity in the loop to purge air and dirt particles from the loop. Flush the loop in both directions with a high volume of water at a high velocity. Follow the steps below to properly flush the loop:

1. Verify power is off.
2. Fill loop with water from hose through flush cart before using flush cart pump to ensure an even fill. Do not allow the water level in the flush cart tank to drop below the pump inlet line to prevent air from filling the line.
3. Maintain a fluid level in the tank above the return tee to avoid air entering back into the fluid.
4. Shutting off the return valve that connects into the flush cart reservoir will allow 50 psig surges to help purge air pockets. This maintains the pump at 50 psig.
5. To purge, keep the pump at 50 psig until maximum pumping pressure is reached.
6. Open the return valve to send a pressure surge through the loop to purge any air pockets in the piping system.
7. A noticeable drop in fluid level will be seen in the flush cart tank. This is the only indication of air in the loop.
NOTE: If air is purged from the system while using a 10 in. PVC flush tank, the level drop will only be 1 to 2 in. since liquids are incompressible. If the level drops more than this, flushing should continue since air is still being compressed in the loop. If level is less than 1 to 2 in., reverse the flow.
8. Repeat this procedure until all air is purged.
9. Restore power.

Antifreeze may be added before, during or after the flushing process. However, depending on when it is added in the process, it can be wasted. Refer to the Antifreeze section on page 45 for more detail.

Loop static pressure will fluctuate with the seasons. Pressures will be higher in the winter months than during the warmer months. This fluctuation is normal and should be considered when charging the system initially. Run the unit in either heating or cooling for several minutes to condition the loop to a homogeneous temperature.

When complete, perform a final flush and pressurize the loop to a static pressure of 40 to 50 psig for winter months or 15 to 20 psig for summer months.

After pressurization, be sure to remove the plug from the end of the loop pump motor(s) to allow trapped air to be discharged and to ensure the motor housing has been flooded. Be sure the loop flow center provides adequate flow through the unit by checking pressure drop across the heat exchanger. Compare the results to the data in Table 13.

System Flow

FLOW VERIFICATION

The 50PS WSHP units do not include a factory flow switch as standard. It is recommend to field installed a flow switch or special order a flow switch as factory installed to prevent the compressor from operating without loop flow.

IMPORTANT: It is recommended to have a flow switch to prevent the unit from running if water flow is lost.

FLOW REGULATION

Flow regulation can be accomplished by two methods. Most water control valves have a flow adjustment built into the valve. By measuring the pressure drop through the unit heat exchanger, the flow rate can be determined. Adjust the water control valve until the desired flow rate is achieved. Since the pressure constantly varies, two pressure gages may be needed in some applications. See Table 13 for flow rates based on waterside pressure drop.

An alternate method of flow regulation is to install an automatic flow control valve. These valves feature a removable cartridge that controls the maximum flow through the valve assembly. Verify that the water flow control cartridge matches the application flow requirement.

Table 13 — Waterside Pressure Drop^a

50PS MODEL SIZE	WATER FLOW RATE (gpm)	WATERSIDE PRESSURE DROP (psi)	WATERSIDE PRESSURE DROP (ft of H ₂ O)
007	1.5	1.3	2.9
	2	2.1	4.9
	3	4.4	10.1
009	2	1.7	3.9
	2.5	2.5	5.8
	3.25	4.0	9.3
012	3	1.5	3.4
	4	2.5	5.8
	5.5	4.5	10.2
015	3	1.4	3.3
	4	2.4	5.5
	5.5	4.3	9.8
018	4	3.0	7.0
	5	4.5	10.4
	6.5	7.3	16.7
024	4.5	1.8	4.1
	6	3.0	6.9
	8	5.1	11.6
030	5.5	0.9	2.1
	7	1.4	3.2
	10	2.7	6.1
036	7.5	1.4	3.3
	10	2.4	5.6
	12.5	3.6	8.4
042	8.75	1.9	4.4
	10.5	2.7	6.1
	13.25	4.0	9.3
048	10.67	2.7	6.3
	12	3.4	7.8
	14	4.5	10.3
060	12	3.4	7.8
	15	5.0	11.7
	17.5	6.7	15.4
070	13.5	2.1	4.9
	17	3.2	7.4
	20.5	4.5	10.4

NOTE(S):

a. All values based upon pure water at 70°F.

ANTIFREEZE

In areas where leaving water temperatures drop below 40°F or where piping will be routed through areas subject to freezing, antifreeze is needed.

Alcohols and glycols are commonly used as antifreeze agents. Freeze protection should be maintained to 15°F below the lowest expected entering loop temperature. For example, if the lowest expected entering loop temperature is 30°F, the leaving loop temperature would be 22 to 25°F. Therefore, the freeze protection should be at 15°F (30°F - 15°F = 15°F).

NOTE: All alcohols should be pre-mixed and pumped from a reservoir outside of the building or introduced under water level to prevent fuming.

Calculate the total volume of fluid in the piping system. See Table 14. Use the percentage by volume in Table 15 to determine the amount of antifreeze to use. Antifreeze concentration should be checked from a well-mixed sample using a hydrometer to measure specific gravity.

Table 14 — Approximate Fluid Volume (gal.) per 100 Ft of Pipe^a

PIPE	DIAMETER (in.)	VOLUME (gal.)
Copper	1	4.1
	1.25	6.4
	1.5	9.2
Rubber Hose	1	3.9
Polyethylene	3/4 IPS SDR11	2.8
	1 IPS SDR11	4.5
	1-1/4 IPS SDR11	8.0
	1/2 IPS SDR11	10.9
	2 IPS SDR11	18.0
	1-1/4 IPS SCH40	8.3
	1-1/2 IPS SCH40	10.9
	2 IPS SCH40	17.0

NOTE(S):

a. Volume of heat exchanger is approximately 1.0 gallon.

LEGEND

- IPS — Internal Pipe Size
- SCH — Schedule
- SDR — Standard Dimensional Ratio

Table 15 — Antifreeze Percentages by Volume

ANTIFREEZE	MINIMUM TEMPERATURE FOR FREEZE PROTECTION (°F)			
	10	15	20	25
Methanol (%)	25	21	16	10
100% USP Food Grade Propylene Glycol (%)	38	30	22	15
Ethanol (%)	29	25	20	14

FREEZE PROTECTION SELECTION

The 26°F FP1 factory setting (water) should be used to avoid freeze damage to the unit.

Once antifreeze is selected, the JW3 jumper (FP1) should be clipped on the control to select the low temperature (antifreeze 15°F) set point to avoid nuisance faults.

START-UP

Use the procedure outlined below to initiate proper unit start-up.

Operating Limits

ENVIRONMENT

This equipment is designed for indoor installation only. Extreme variations in temperature, humidity and corrosive water or air will adversely affect the unit performance, reliability and service life.

NOTE: Two factors determine the operating limits of a unit: entering-air temperature and water temperature. Whenever any of these factors are at a minimum or maximum level, the other two factors must be at a normal level to ensure proper unit operation.

POWER SUPPLY

A voltage variation of ± 10% of nameplate utilization voltage is acceptable.

UNIT STARTING CONDITIONS

Depending on the model, units should start and operate with entering water temperature temperatures between 20°F and 110°F and entering air temperatures between 45°F and 95°F. Water flow rates should be between 1.5 and 3.0 GPM/nominal cooling ton.

NOTE: These operating limits are not normal or continuous operating conditions. Assume that such a start-up is for the purpose of bringing the building space up to occupancy temperature. See Table 16 for operating limits.

Table 16 — Operating Limits

AIR LIMITS	STANDARD UNIT	EXTENDED RANGE OPTION
COOLING		
Minimum cooling entering air db/wb F	68/57	68/57
Maximum cooling entering air db/wb F	95/85	95/85
Minimum cooling entering fluid temp. F	70	50
Water loop typical coil entering fluid range temperature F	70/90	70/90
Maximum cooling entering fluid temperature F	110	110
HEATING		
Minimum heating entering air db F	50	50
Maximum heating entering air db F	80	80
Normal water coil entering fluid range F	50-80	25-80 ^a
Minimum water coil entering Fluid F	50	25 ^a

NOTE(S):

a. Antifreeze solution is required at these fluid temperatures.

LEGEND

- DB — Dry Bulb
- WB — Wet Bulb

Start-Up Procedure

⚠ WARNING

When the disconnect switch is closed, high voltage is present in some areas of the electrical panel. Exercise caution when working with the energized equipment. Failure to heed this warning could lead to personal injury.

- Restore power to system.
- Turn thermostat blower position to ON or use the DDC interface to enable the unit blower. The blower should start.
- Balance airflow at diffusers/dampers.
- Adjust all water valves to the full open position.
- Use the thermostat or DDC control to enable the compressor by placing the unit in cooling mode.
- Verify compressor operation. If scroll compressor, verify compressor rotation direction.

SCROLL COMPRESSOR ROTATION

It is important to be certain compressor is rotating in the proper direction. To determine whether or not compressor is rotating in the proper direction:

- Connect service gages to suction and discharge pressure fittings.
- Energize the compressor by using the thermostat or DDC control to put the unit in cooling mode.
- The suction pressure should drop and the discharge pressure should rise, as is normal on any start-up.

If the suction pressure does not drop and the discharge pressure does not rise to normal levels:

- Turn off power to the unit. Install disconnect tag.
- Reverse any two of the unit power leads.
- Reapply power to the unit and verify pressures are correct. The suction and discharge pressure levels should now move to their normal start-up levels.

When the compressor is rotating in the wrong direction, the unit makes more noise and does not provide cooling.

After a few minutes of reverse operation, the scroll compressor internal overload protection will open, thus activating the unit lockout. This requires a manual reset. To reset the lockout, turn the thermostat on and then off or power cycle the unit power feed.

NOTE: There is a 5-minute time delay before the compressor will re-start.

COOLING MODE START-UP

See Tables 17 and 18 for typical unit operating pressures and temperatures.

1. Using the thermostat or DDC control, operate the unit in the cooling cycle. Refer to Table 16 for operating limits. Allow the unit to run for a minimum of five minutes and record the operating data.
2. Check for water leaks and vibration.
3. Check for cool air delivery at unit grille a few minutes after the unit has begun to operate.
4. Verify that compressor is on and that water flow rate is correct by measuring pressure drop through the heat exchanger using P/T plugs. Check the elevation and cleanliness of the condensate lines; any dripping could be a sign of a blocked line. Be sure the condensate trap includes a water seal.
5. Check the temperature of both supply and discharge water. Compare to Tables 17-18. If temperature is within range, proceed. If temperature is outside the range, check the cooling refrigerant pressures in Tables 17-18.

6. Check air temperature drop across the coil when compressor is operating. Air temperature drop should be between 15°F and 25°F.
7. Disable cooling mode and wait a period of 5 minutes to allow system pressures to equalize.

HEATING MODE START-UP

See Tables 17 and 18 for typical unit operating pressures and temperatures.

1. After waiting for a period of 5 minutes after the cooling cycle, use the thermostat or DDC control to operate the unit in the heating cycle. Refer to Table 16 for operating limits. Allow the unit to run for a minimum of five minutes and record the operating data.
2. Check for water leaks and vibration.
3. Check for warm air delivery at unit grille a few minutes after the unit has begun to operate.
4. Verify that the compressor is on and that the water flow rate is correct by measuring pressure drop through the heat exchanger using P/T plugs.
5. Check the temperature of both supply and discharge water. Compare to Tables 17-18. If temperature is within range, proceed. If temperature is outside the range, check the cooling refrigerant pressures in Tables 17-18.
6. Check air temperature rise across the coil when compressor is operating. Air temperature rise should be between 20°F and 30°F.
7. Disable heating mode.

Table 17 — Typical Air Temperature Rise/Fall Ranges^a

ENTERING FLUID TEMP. (°F)	COOLING		HEATING	
	ENTERING AIR TEMP (°F)	AIR TEMP DROP (°F)	ENTERING AIR TEMP (°F)	AIR TEMP RISE (°F)
30	—	—	60	15.9 to 23.5
	—	—	70	13.5 to 22.9
	—	—	80	14.8 to 22.4
40	75/63	20.6 to 25.0	60	18.5 to 26.7
	80/67	21.6 to 25.6	70	17.9 to 26
	85/71	22.5 to 26.2	80	17.2 to 25.5
50	75/63	20.3 to 24.4	60	21.3 to 30
	80/67	20.6 to 24.4	70	23.3 to 33
	85/71	21.5 to 25.2	80	22.5 to 32.3
60	75/63	19.0 to 23.2	60	27 to 37.6
	80/67	20.2 to 23.8	70	26.1 to 37.1
	85/71	20.8 to 24.5	80	25.2 to 36.2
70	75/63	18.5 to 22.5	60	30 to 41.7
	80/67	19.3 to 23.2	70	29 to 40.8
	85/71	20.5 to 23.9	80	28 to 39.9
80	75/63	18.8 to 22.2	—	—
	80/67	19.1 to 23	—	—
	85/71	20.3 to 23.6	—	—
85	75/63	18.8 to 22.2	—	—
	80/67	19.1 to 23	—	—
	85/71	20.3 to 23.6	—	—
90	75/63	19 to 21.8	—	—
	80/67	18.9 to 22.7	—	—
	85/71	20 to 23.3	—	—
100	75/63	17.2 to 21.3	—	—
	80/67	18.4 to 22.1	—	—
	85/71	19.5 to 22.7	—	—
110	75/63	16 to 20.7	—	—
	80/67	17.1 to 21.4	—	—
	85/71	18.2 to 22.2	—	—

NOTE(S):

- a. This chart shows approximate air temperatures rise/fall for a unit in good repair. The values shown are meant as a guide only and should not be used to estimate system charge. This chart assumes rated flow air and rated water flow. Heating data at entering fluid temperatures below 50°F assumes the use of antifreeze. As a result of continuing research and development, specifications are subject to change without notice.

Table 18 — Typical Refrigerant Pressure Ranges^a

ENTERING FLUID TEMP (°F)	TEMP. DIFFERENCE (F)	COOLING						HEATING			
		Entering Air Temp (Dry Bulb) (°F)						Entering Air Temp (Dry Bulb) (°F)			
		70		75		80		60		70	
		Suction	Discharge	Suction	Discharge	Suction	Discharge	Suction	Discharge	Suction	Discharge
30	5	—	—	—	—	—	—	68 to 79	233 to 266	71 to 84	269 to 316
	10	—	—	—	—	—	—	65 to 76	222 to 255	68 to 80	255 to 291
	15	—	—	—	—	—	—	59 to 71	216 to 248	62 to 75	245 to 283
40	5	113 to 147	138 to 156	117 to 152	142 to 161	119 to 155	145 to 164	80 to 95	244 to 282	85 to 100	289 to 317
	10	113 to 147	145 to 164	117 to 152	150 to 170	119 to 155	153 to 173	77 to 91	237 to 274	82 to 96	269 to 306
	15	113 to 147	151 to 170	117 to 152	156 to 175	119 to 155	159 to 179	72 to 86	226 to 262	76 to 90	258 to 297
50	5	115 to 149	164 to 185	119 to 154	170 to 191	121 to 157	173 to 195	95 to 113	255 to 302	100 to 119	287 to 337
	10	115 to 149	173 to 194	119 to 154	178 to 200	121 to 157	182 to 204	91 to 109	248 to 290	96 to 115	281 to 323
	15	115 to 149	179 to 200	119 to 154	184 to 207	121 to 157	188 to 211	86 to 103	237 to 282	90 to 108	269 to 316
60	5	117 to 151	194 to 218	121 to 156	200 to 224	123 to 159	204 to 229	111 to 133	270 to 324	117 to 141	302 to 360
	10	117 to 151	204 to 228	121 to 156	211 to 235	123 to 159	215 to 240	106 to 129	258 to 311	112 to 136	294 to 341
	15	117 to 151	211 to 235	121 to 156	218 to 242	123 to 159	222 to 247	101 to 122	251 to 302	106 to 128	283 to 337
70	5	119 to 153	228 to 254	122 to 158	235 to 262	125 to 161	240 to 267	129 to 158	282 to 343	136 to 167	314 to 378
	10	119 to 153	238 to 265	122 to 158	246 to 273	125 to 161	251 to 279	124 to 150	274 to 333	131 to 159	307 to 362
	15	119 to 153	246 to 273	122 to 158	254 to 281	125 to 161	259 to 287	117 to 146	262 to 320	123 to 154	294 to 355
80	5	121 to 155	265 to 294	124 to 160	273 to 303	127 to 163	279 to 309	148 to 184	299 to 366	156 to 194	331 to 405
	10	121 to 155	276 to 306	124 to 160	285 to 316	127 to 163	291 to 322	143 to 176	286 to 352	151 to 185	322 to 383
	15	121 to 155	285 to 315	124 to 160	294 to 325	127 to 163	300 to 332	136 to 169	278 to 343	143 to 179	311 to 378
90	5	123 to 157	306 to 337	126 to 162	316 to 348	129 to 165	322 to 355	—	—	—	—
	10	123 to 157	319 to 351	126 to 162	329 to 363	129 to 165	336 to 370	—	—	—	—
	15	123 to 157	329 to 362	126 to 162	339 to 373	129 to 165	346 to 381	—	—	—	—
100	5	124 to 159	351 to 387	128 to 164	363 to 399	131 to 167	370 to 407	—	—	—	—
	10	124 to 159	367 to 403	128 to 164	378 to 416	131 to 167	386 to 424	—	—	—	—
	15	124 to 159	376 to 413	128 to 164	388 to 426	131 to 167	396 to 435	—	—	—	—
110	5	126 to 161	403 to 441	130 to 166	416 to 455	133 to 169	424 to 464	—	—	—	—
	10	126 to 161	419 to 458	130 to 166	432 to 472	133 to 169	441 to 482	—	—	—	—
	15	126 to 161	429 to 470	130 to 166	443 to 485	133 to 169	452 to 495	—	—	—	—

NOTE(S):

a. This chart shows approximate temperatures and pressures for a unit in good repair. The values shown are meant as a guide only and should not be used to estimate system charge. This chart assumes rated air flow and 80° db/67° wb entering air temperature in cooling, 70° db entering air temperature in heating. Heating data at entering fluid temperatures below 50° assumes the use of antifreeze. As a result of continuing research and development, specifications are subject to change without notice.

OPERATION

Power Up Mode

The unit will not operate until all the inputs, terminals and safety controls are checked for normal operation.

NOTE: The compressor will have a 5-minute anti-short cycle upon power up.

Unit Protection Module (UPM)

Figure 39 shows the UPM sequence of operations for unit safeties. All 50PS units are equipped with a UPM.

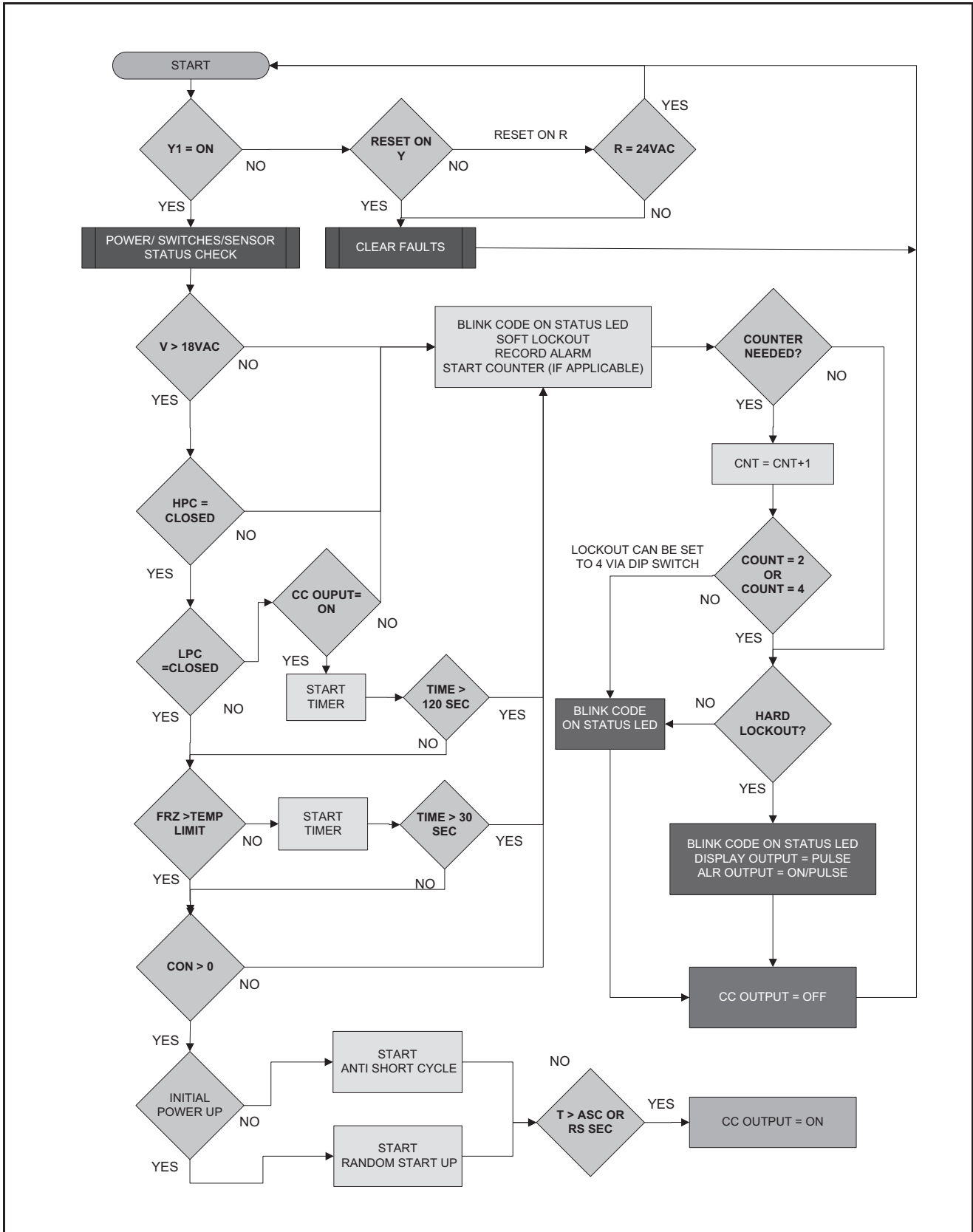

Fig. 39 — UPM Sequence of Operations

Units with Complete C or Deluxe D Controls

STANDBY

The Y and W terminals are not active in Standby mode; however, the O and G terminals may be active, depending on the application. The compressor will be off.

COOLING

Y and O terminals are active in Cooling mode. After power up, the first call to the compressor will initiate a 270 to 300 second random start delay and a 5-minute anti-short cycle protection time delay. After both delays are complete, the compressor is energized.

NOTE: On all subsequent compressor calls the random start delay is omitted.

HEATING STAGE 1

Terminal Y is active in heating stage 1. After power up, the first call to the compressor will initiate a 270 to 300 second random start delay and a 5-minute anti-short cycle protection time delay. After both delays are complete, the compressor is energized.

NOTE: On all subsequent compressor calls the random start delay is omitted.

HOT GAS REHEAT (OPTIONAL FOR COMPLETE C OR DELUXE D CONTROLS)

Terminal H is active in dehumidification mode with hot gas reheat. After a call for H, the reversing valve (O), compressor (Y), and fan (G) are also enabled.

NOTE: Any call for cooling (Y), heating (Y or W), or reversing valve (O) will override dehumidification mode (H).

WATERSIDE ECONOMIZER (OPTIONAL FOR COMPLETE C OR DELUXE D CONTROLS)

Y and O terminals are active in Cooling mode. When the entering water temperature drops below the entering water temperature set point on the waterside economizer aquastat, the compressor and reversing valve are disabled and the waterside economizer is enabled. The waterside economizer three way control valve will divert water to the economizer coil for free cooling. When the entering water temperature rises above the aquastat set point, the waterside economizer is disabled and the compressor and reversing valve are enabled.

TWO WAY WATER FLOW CONTROL VALVE (OPTIONAL)

The two way water flow control valve is enabled anytime there is a call for cooling (Y), heating (Y), or dehumidification (H) and allows water to flow through the unit. When there is no call for cooling, heating, or dehumidification, the water flow control valve is disabled, stopping flow through the unit.

BOILERLESS HEAT (DELUXE D ONLY)

When the entering water temperature is below the boilerless heat aquastat entering water temperature set point and there is a call for heating (Y), the compressor is disabled and the auxiliary heat output is enabled. When the entering water temperature is above the aquastat set point, the auxiliary heat output is disabled and the compressor is enabled.

PUMP/VALVE RELAY (DELUXE D ONLY)

The pump/valve relay is enabled anytime there is a call for cooling (Y), heating (Y), or dehumidification (H) and can be used to enable/disable field installed flow control valves or circulator pumps. When there is no call for cooling, heating, or dehumidification, pump/valve relay is disabled.

Units with WSHP Open Controls

Units with WSHP Open still feature a UPM board for unit operation, so the operation will be similar to the sequence for the other control packages. WSHP Open does feature advanced functionality, such as automatic fan speed control and intelligent alarming,

which will differ from the other control packages. Below is an overview of the different features for the WSHP Open controls. For more details of the WSHP Open operation, please refer to the WSHP Open Integration Guide and the WSHP Points/Properties Manual. See Fig. 40 for WSHP Open Control Board overview.

COOLING

The control will operate one or two stages of compression to maintain the desired cooling set point. To improve dehumidification and reduce noise, the control operates the fan at the lowest speed possible to satisfy the load conditions. If cooling is active and should the SAT approach the minimum SAT limit, the fan will be indexed to the next higher speed. Should this be insufficient and if the SAT falls further (equal to the minimum SAT limit), the fan will be indexed to the maximum speed. If the SAT still continues to fall 5 degrees below the minimum SAT limit, all cooling stages will be disabled.

During Cooling, the reversing valve output will be held in the cooling position (either B or O type as configured) even after the compressor is stopped. The valve will not switch position until the opposite mode is required.

REVERSE CYCLE HEATING

The control will operate one or two stages of compression to maintain the desired heating set point. To reduce noise, the control operates the fan at the lowest speed possible. If the heating is active and should the SAT approach the maximum SAT limit, the fan will be indexed to the next higher speed. Should this be insufficient, then if the SAT rises further and reaches the Maximum Heating SAT limit, the fan will be indexed to the maximum speed. If the SAT still continues to rise 5°F above the maximum limit, all heating stages will be disabled.

During Heating, the reversing valve output will be held in the heating position (either B or O type as configured) even after the compressor is stopped. The valve will not switch position until the opposite mode is required.

TWO POSITION OA DAMPER

The control can be configured to operate a 2-position ventilation damper to provide the minimum ventilation requirements during occupied periods.

MODULATING OA DAMPER WITH DCV

The control can be configured to operate a modulating ventilation damper during occupied periods that responds to changing CO₂ levels from an optional sensor. The control monitors the CO₂ level and compares it to the configured set points and adjusts the ventilation rate as required. The control provides proportional ventilation to meet the requirements of ASHRAE specifications by providing a base ventilation rate and then increasing the rate as the CO₂ level increases. The control has three user adjustable set points; start ventilation maximum ventilation and maximum damper position. The control will begin to proportionally increase ventilation when the CO₂ level rises above the start ventilation set point and will reach the full ventilation rate (maximum damper position) when the CO₂ level is at or above maximum set point. A user configurable minimum damper position ensures that proper base ventilation is delivered when occupants are not present.

AUXILIARY MODULATING HOT WATER / STEAM HEATING REHEAT

The control can modulate a hot water or steam valve connected to a coil on the discharge side of the unit and supplied by a boiler in order to maintain the desired heating set point should the compressor capacity be insufficient or a compressor failure occurs. Unless the compressor fails, the valve will only operate to supplement the heat provided by the compressor if the space temperature falls two degrees or more below the desired heating set point. The valve will be controlled so the SAT will not exceed the Maximum Heating SAT limit.

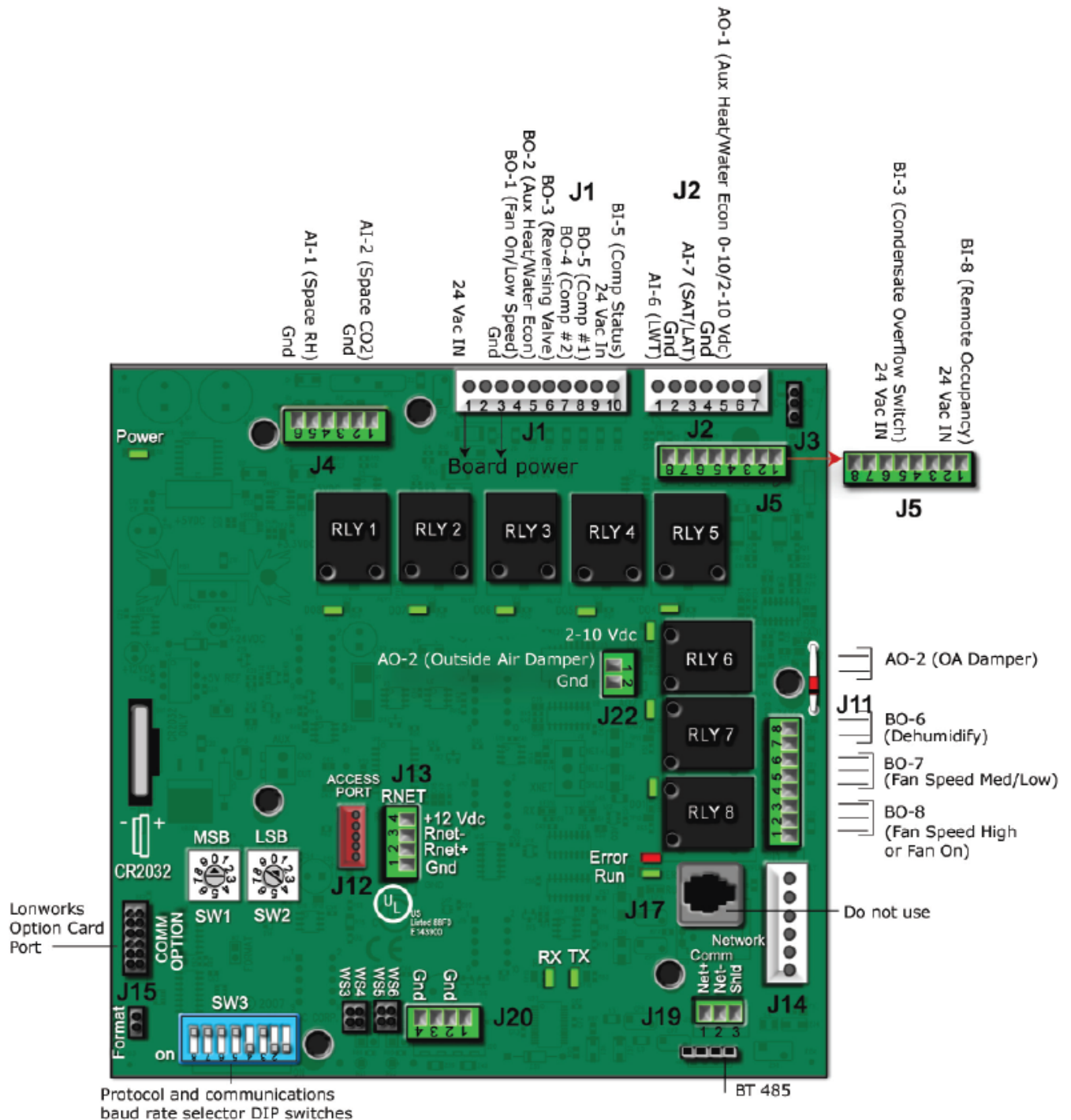

Fig. 40 — WSHP Open Control Board

2-POSITION HOT WATER / STEAM HEATING REHEAT

The control can operate a two position, NO or NC, hot water or steam valve connected to a coil on the discharge side of the unit and supplied by a boiler in order to maintain the desired heating set point should the compressor capacity be insufficient or a compressor failure occurs. Unless the compressor fails, the valve will only open to supplement the heat provided by the compressor if the space temperature falls two degrees or more below the desired heating set point. The valve will be controlled so the SAT will not exceed the Maximum Heating SAT limit and subject to a two minute minimum OFF time to prevent excessive valve cycling.

SINGLE STAGE ELECTRIC AUXILIARY HEAT

The control can operate a single stage of electric heat connected to a coil on the discharge side of the unit in order to maintain the desired heating set point should the compressor capacity be insufficient or a compressor failure occurs. Unless the compressor fails, the heat stage will only operate to supplement the heat provided by the compressor if the space temperature falls two degrees or more below the desired heating set point. The heat stage will be controlled so the SAT will not exceed the Maximum Heating SAT limit and subject to a two minute minimum OFF time to prevent excessive cycling.

AUTOMATIC FAN SPEED CONTROL

The control is capable of controlling up to three fan speeds. The motor will operate at the lowest speed possible to provide quiet and efficient fan operation. The motor will increase speed if additional cooling or heating is required to maintain the desired space temperature set point. The control increases the motor's speed by one step for each 2°F above the cooling or below the heating set point. Also, the control will increase the fan speed as the Supply Air Temperature approaches the configured minimum or maximum limits. Fan speed for PSC motors is controlled by energizing and de-energizing low, medium and high speed relays. Fan speed for ECMs is controlled by first energizing the low speed tap. If a higher speed is required, the low speed tap remains energized while the medium speed tap is also energized. If high motor speed is required, all three speed taps are energized. If more than one speed tap is energized for an ECM, the ECM will default to the higher speed.

FAN SPEED CONTROL - DURING HEATING

Whenever heat is required and active, the control continuously monitors the supply air temperature to verify it does not rise above the configured Maximum Heating SAT Limit (110°F Default). As the SAT approaches this value, the control will increase the fan speed as required to ensure the SAT will remain within the limit. This feature provides the most quiet and efficient operation by operating the fan at the lowest speed possible.

FAN SPEED CONTROL - DURING COOLING

Whenever mechanical cooling is required and active, the control continuously monitors the supply air temperature to verify it does not fall below the configured Minimum Cooling SAT Limit (50°F Default). As the SAT approaches this value, the control will increase the fan speed as required to insure the SAT will remain within the limit.

MODULATING WATER ECONOMIZER CONTROL

The control has the capability to modulate a water valve to control condenser water flowing through a coil on the entering air side of the unit.

Cooling

The purpose is to provide an economizer cooling function by using the water loop when the entering water loop temperature is suitable (at least 5°F below space temperature). If the water loop conditions are suitable, then the valve will modulate open as required to maintain a Supply Air Temperature that meets the load conditions. Should the economizer coil capacity be insufficient for a period greater than 5 minutes, or should a high humidity condition occur, then the compressor will be started to satisfy the load. As the SAT approaches the Minimum Cooling SAT limit, the economizer valve will modulate closed during compressor operation.

Heating

Additionally, the control will modulate the water valve should the entering water loop temperature be suitable for heating (at least 5°F above space temperature) and heat is required. The valve will be controlled in a similar manner except to satisfy the heating requirement. Should the coil capacity be insufficient to satisfy the space load conditions for more than 5 minutes, then the compressor will be started to satisfy the load. As the SAT approaches the Maximum Heating SAT limit, the economizer valve will modulate closed during compressor operation.

2-POSITION WATER ECONOMIZER CONTROL

The control has the capability to open a NO or NC, two position, water valve to control condenser water flow through a coil on the entering air side of the unit.

Cooling

The purpose is to provide a cooling economizer function directly from the condenser water loop when the entering water loop temperature is suitable (at least 5°F below space temperature). If the

optional coil is provided and the water loop conditions are suitable, then the valve will open to provide cooling to the space when required. Should the capacity be insufficient for a period greater than 5 minutes, or should a high humidity condition occur, then the compressor will be started to satisfy the load. Should the SAT reach the Minimum Cooling SAT limit, the economizer valve will close during compressor operation.

Heating

Additionally, the economizer control will open the water valve should the entering water loop temperature be suitable for heating (at least 5°F above space temperature) and heat is required. The valve will be controlled in a similar manner except to satisfy the heating requirement. Should the coil capacity be insufficient to satisfy the space load for more than 5 minutes, then the compressor will be started to satisfy the load. Should the SAT reach the Maximum Heating SAT limit, the economizer valve will close during compressor operation.

POWER FAIL RESTART DELAY

The control provides a delay when recovering from a power failure in order to ensure stable utility power and to prevent excessive demand when many units start simultaneously. Each unit can be user configured for a unique delay between 0 and 600 seconds. The factory programmed default delay is 60 seconds. (Note that the onboard control will not start the compressor on any call for heating, cooling or dehumidification until 5 minutes has elapsed from the power restoration. If a lower restart time delay is configured, only the fan start will be affected as the internal logic boards will prevent compressor operation for more than 300 seconds).

SUPPLY AIR TEMPERATURE MONITORING / CONTROL / ALARM

The control has 2 configurable control limits for supply air temperature. The control will monitor the supply air temperature (SAT) and verify it is within limits. During cooling, the control will increase fan speed and reduce compressor stages should the SAT approach the Maximum Cooling SAT limit. Likewise, during heating, should the SAT approach the Maximum Heating SAT limit, the fan speed will be increased, followed by reducing compressor stages. Auxiliary heating coils are controlled so as not to exceed the Maximum Heating SAT limit. Additionally, a separate High SAT Alarm Limit and Low SAT Alarm Limit are provided so that an alarm can be generated to indicate an abnormal SAT condition should the SAT exceeds the alarm limit for more than 1 minute.

DEHUMIDIFICATION

The control can monitor the space relative humidity and if the unit is equipped with the factory installed hot gas reheat, whenever the humidity exceeds the appropriate (occupied or unoccupied) humidity set point and if the unit is not heating or cooling, the control will activate cooling (compressor and reversing valve) and the hot gas reheat outputs to start dehumidification. The fan will operate at medium speed if equipped with a three speed fan.

SPACE TEMPERATURE ALARMS

The control provides the ability to generate an alarm whenever the space temperature exceeds the alarm set point. A separate occupied hysteresis and unoccupied high and low alarm set points are provided. The control provides a 5 minute alarm delay during unoccupied periods. During occupied periods, the control uses the occupied temperature set point and applies the hysteresis value to determine the alarm set points. Whenever an occupancy transition from unoccupied to occupied occurs or the occupied temperature set points are changed causing an alarm condition to occur, the control will automatically calculate an alarm delay (equivalent to the configured delay time in minutes / deg F times the temperature error that occurred). This will prevent nuisance alarms whenever an occupancy change occurs and allows time for the unit to correct an alarming temperature condition.

CONDENSER WATER TEMPERATURE MONITORING / CONTROL / ALARM

The control has 4 configurable alarm limits for condenser water temperature. The control will verify that the water temperature is within operating range (between high and low limits) for the specific operating mode (heating or cooling) before energizing the compressor. Once the compressor is started, the condenser water temperature is further monitored to verify that it is within limits to insure sufficient water is flowing through the coil. Should the leaving water temperature rise above or fall below the appropriate limits, and alarm is generated and the compressors will be shut down if the condition occurs for more than 15 seconds.

HIGH CONDENSATE / OVERFLOW ALARM

The control will monitor a discrete input to determine the state of a condensate level switch. The input can be configured to alarm on either an open or closed switch condition. Should this input be in an alarm state, the control will start a timer and after the timer exceeds a configurable 'Condensate Overflow Alarm Delay' limit (10 seconds default), the control will generate an alarm and the unit will disable the compressor, dehumidification and fan outputs.

FILTER STATUS ALARM

The control provides the ability to generate a dirty filter alarm after the number of fan run hours exceeds a configurable filter alarm timer limit. The control monitors the fan output and if the fan is operating at any speed, it accumulates run time. Should the fan run time hours exceed the configurable limit, an alarm is generated. To reset the alarm timer after the alarm has been generated, a 'Reset Filter Alarm' input is provided. The filter alarm can be disabled by setting the 'Filter Alarm Timer Delay' to zero (factory default).

COMPRESSOR FAULT/LOCKOUT ALARM

The control will monitor a discrete input to determine the compressor state. Should the input state not match the desired compressor operating state for greater than 6 minutes, the control assumes the compressor has been locked-out and will generate an alarm. Also, when this fault occurs and if the unit is equipped with an auxiliary heating coil or a water economizer and the water temperature is suitable for heating, should heating be required, the control will utilize the auxiliary heating source as the primary heating source until the fault condition is corrected.

INSUFFICIENT VENTILATION ALARM

The control provides the ability to generate a high CO₂ level alarm during occupied periods whenever the CO₂ sensor value exceeds the user adjustable limit. Whenever an occupancy transition from unoccupied to occupied occurs, or the occupied alarm limit is changed to a value that causes an alarm condition to occur, the control will automatically calculate an alarm delay based on the error from set point (15 minutes minimum). This prevents nuisance alarms from occurring when occupancy changes. The IAQ alarm can be disabled by setting 'Occupied High IAQ Alarm Limit' to zero.

RELATIVE HUMIDITY ALARM

The control provides the ability to generate an alarm whenever the space relative humidity exceeds the alarm set point. A separate occupied and unoccupied alarm set point is provided. The control provides a 5 minute alarm delay during unoccupied periods. During occupied periods, the controller uses the occupied high RH alarm limit. Whenever an occupancy transition from unoccupied to occupied occurs or the occupied high alarm limit is lowered causing an alarm condition to occur, the control will automatically calculate an alarm delay (equivalent to the configured delay time in minutes / % RH times the humidity error condition that occurred). This will prevent nuisance alarms whenever an occupancy change occurs and allows time for the unit to correct an alarming humidity condition.

TIME SCHEDULES

The control has an onboard time clock and configurable time schedules to provide occupancy scheduling.

HOLIDAY SCHEDULES

The control has holiday schedules that can be programmed to override the normal occupancy operation and cause the unit to go unoccupied for the duration of the schedule. Each schedule consists of a start date and time and an end date and time so each schedule can span more than a single day duration.

OVERRIDE SCHEDULES

The control has override schedules that can be programmed to override the normal occupancy and holiday operation and cause the unit to go occupied for the duration of the schedule. Each schedule consists of a start date and time and an end date and time so each schedule can span more than a single day duration.

SERVICE

Perform the procedures outlined below periodically, as indicated.

An annual "checkup" is recommended by a licensed refrigeration mechanic. Recording the performance measurements of volts, amps, and water temperature differences (both heating and cooling) is recommended. This data should be compared to the information on the unit's data plate and the data taken at the original startup of the equipment.

Periodic lockouts almost always are caused by air or water flow problems. The lockout (shutdown) of the unit is a normal protective measure in the design of the equipment. If continual lockouts occur, call a mechanic immediately and have them check for: water flow problems, water temperature problems, air flow problems or air temperature problems. Use of the pressure and temperature charts for the unit may be required to properly determine the cause.

WARNING

To prevent injury or death due to electrical shock or contact with moving parts, open unit disconnect switch before servicing unit.

IMPORTANT: When a compressor is removed from this unit, system refrigerant circuit oil will remain in the compressor. To avoid leakage of compressor oil, the refrigerant lines of the compressor must be sealed after it is removed.

IMPORTANT: All refrigerant discharged from this unit must be recovered without exception. Technicians must follow industry accepted guidelines and all local, state and federal statutes for the recovery and disposal of refrigerants.

IMPORTANT: To avoid the release of refrigerant into the atmosphere, the refrigerant circuit of this unit must only be serviced by technicians who meet local, state and federal proficiency requirements.

Filters

Filter changes or cleanings are required at regular intervals. The time period between filter changes will depend upon the type of environment the equipment is used in. In a single family home that is not under construction, changing or cleaning the filter every 60 days may be sufficient. In other applications such as motels, where daily vacuuming produces a large amount of lint, filter changes may need to be as frequent as biweekly. See Fig. 1 and 2 for replacement filter sizes.

NOTE: Horizontal units containing two filters are taped together at the factory to facilitate removal. This should be done by end user as new filters are installed.

IMPORTANT: Units should never be operated without a filter.

Water Coil

Keep all air out of the water coil. Check open loop systems to be sure the well head is not allowing air to infiltrate the water line. Always keep lines airtight.

Inspect heat exchangers regularly, and clean more frequently if the unit is located in a “dirty” environment. Keep the heat exchanger full of water at all times. Open loop systems should have an inverted P trap placed in the discharge line to keep water in the heat exchanger during off cycles. Closed loop systems must have a minimum of 15 psig during the summer and 40 psig during the winter. Check P trap frequently for proper operation.

CAUTION

To avoid fouled machinery and extensive unit clean-up, DO NOT operate units without filters in place. DO NOT use equipment as a temporary heat source during construction.

Condensate Drain Pans

The condensate drain should be checked annually by cleaning and flushing to ensure proper drainage.

Check condensate drain pans for algae growth twice a year. If algae growth is apparent, consult a water treatment specialist for proper chemical treatment. Applying an algicide every three months will typically eliminate algae problems in most locations.

Refrigerant System

Verify air and water flow rates are at proper levels before servicing. To maintain sealed circuitry integrity, do not install service gages unless unit operation appears abnormal.

Check to see that unit is within the superheat and subcooling temperature ranges. If the unit is not within these ranges, recover and reweigh in refrigerant charge.

Compressor

Conduct annual amperage checks to ensure that amp draw is no more than 10% greater than indicated on the serial plate data.

Fan Motors

All units have lubricated fan motors. Fan motors should never be lubricated unless obvious, dry operation is suspected. Periodic maintenance oiling is NOT recommended, as it will result in dirt accumulating in the excess oil and cause eventual motor failure. Conduct annual dry operation check and amperage check to ensure amp draw is no more than 10% greater than indicated on serial plate data.

Condensate Drain Cleaning

Clean the drain line and unit drain pan at the start of each cooling season. Check flow by pouring water into drain. Be sure trap is filled to maintain an air seal.

Air Coil Cleaning

Remove dirt and debris from evaporator coil as required by condition of the coil. Clean coil with a stiff brush, vacuum cleaner, or compressed air. Use a fin comb of the correct tooth spacing when straightening mashed or bent coil fins.

Condenser Cleaning

Water-cooled condensers may require cleaning of scale (water deposits) due to improperly maintained closed-loop water systems. Sludge build-up may need to be cleaned in an open water tower system due to induced contaminants.

Local water conditions may cause excessive fouling or pitting of tubes. Condenser tubes should therefore be cleaned at least once a year, or more often if the water is contaminated.

Proper water treatment can minimize tube fouling and pitting. If such conditions are anticipated, water treatment analysis is recommended. Refer to the Carrier System Design Manual, Part 5, for general water conditioning information.

CAUTION

Follow all safety codes. Wear safety glasses and rubber gloves when using inhibited hydrochloric acid solution. Observe and follow acid manufacturer’s instructions.

Clean condensers with an inhibited hydrochloric acid solution. The acid can stain hands and clothing, damage concrete, and, without inhibitor, damage steel. Cover surroundings to guard against splashing. Vapors from vent pipe are not harmful, but take care to prevent liquid from being carried over by the gases.

Warm solution acts faster, but cold solution is just as effective if applied for a longer period.

GRAVITY FLOW METHOD

Do not add solution faster than vent can exhaust the generated gases. When condenser is full, allow solution to remain overnight, then drain condenser and flush with clean water. Follow acid manufacturer’s instructions. See Fig. 41.

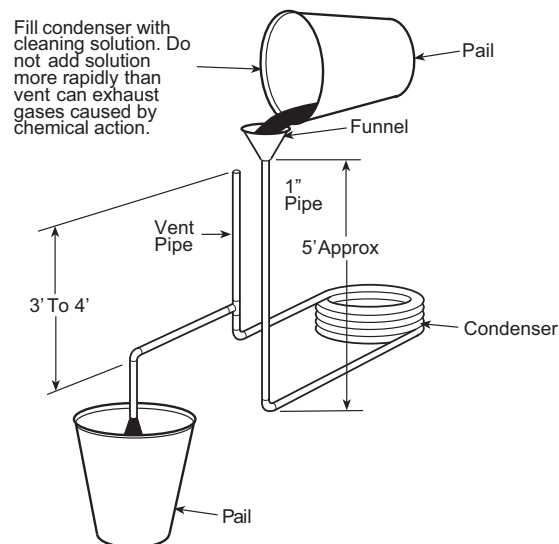

Fig. 41 — Gravity Flow Method

FORCED CIRCULATION METHOD

Fully open vent pipe when filling condenser. The vent may be closed when condenser is full and pump is operating. See Fig. 42.

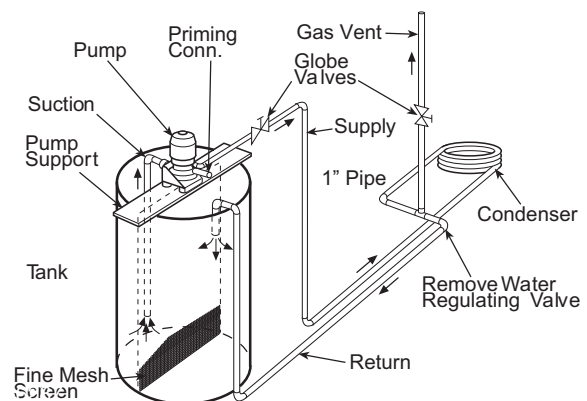

Fig. 42 — Forced Circulation Method

Regulate flow to condenser with a supply line valve. If pump is a non overloading type, the valve may be fully closed while pump is running.

For average scale deposit, allow solution to remain in condenser overnight. For heavy scale deposit, allow 24 hours. Drain condenser and flush with clean water. Follow acid manufacturer's instructions.

Checking System Charge

Units are shipped with full operating charge. If recharging is necessary:

1. Insert thermometer bulb in insulating rubber sleeve on liquid line near filter drier. Use a digital thermometer for all temperature measurements. **DO NOT** use a mercury or dial-type thermometer.
2. Connect pressure gage to discharge line near compressor.
3. After unit conditions have stabilized, read head pressure on discharge line gage.
4. **NOTE:** Operate unit a minimum of 15 minutes before checking charge.
5. From standard field-supplied Pressure-Temperature chart for R-410A, find equivalent saturated condensing temperature.
6. Read liquid line temperature on thermometer; then subtract from saturated condensing temperature. The difference equals subcooling temperature.
7. Compare the subcooling temperature with the normal temperature. If the measured liquid line temperature does not agree with the required liquid line temperature, **ADD** refrigerant to raise the temperature or **REMOVE** refrigerant (using standard practices) to lower the temperature (allow a tolerance of $\pm 3^{\circ}\text{F}$).

Refrigerant Charging

⚠ WARNING

To prevent personal injury, wear safety glasses and gloves when handling refrigerant. Do not overcharge system — this can cause compressor flooding.

NOTE: Do not vent or depressurize unit refrigerant to atmosphere. Remove and recover refrigerant following accepted practices.

Air Coil Fan Motor Removal

⚠ CAUTION

Before attempting to remove fan motors or motor mounts, place a piece of plywood over evaporator coils to prevent coil damage.

Disconnect motor power wires from motor terminals before motor is removed from unit.

1. Shut off unit main power supply.
2. Loosen bolts on mounting bracket and remove inlet ring.
3. Remove motor.

Slide motor/bracket assembly to extreme right and lift out through space between fan scroll and side frame. Rest motor on a high platform such as a step ladder. Do not allow motor to hang by its power wires.

TROUBLESHOOTING

When troubleshooting problems with a WSHP, consider the following.

UNIT PROTECTION MODULE (UPM)

Each unit is factory provided with a UPM board that controls the compressor operation and monitors the safeties. The UPM board

should be one of the first areas to start with troubleshooting an equipment issue. See Fig. 43.

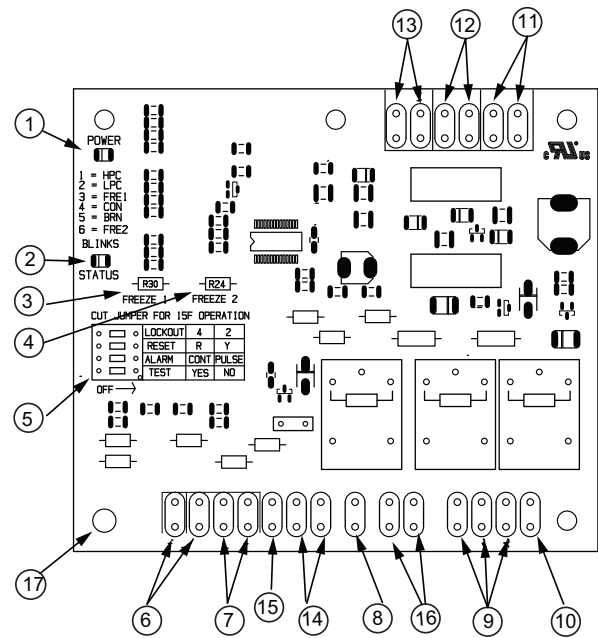

1	Board Power Indicator
2	UPM Status LED Indicator
3	Water Coil Freeze Protection Temperature Selection [R30]
4	Air Coil Freeze Protection Temperature Selection
5	UPM Settings
6	Water Coil Freeze Connection
7	Air Coil Freeze Connection
8	LED Status-Diagnostic Connection
9	24VAC Power Input
10	Compressor Contact Output
11	High Pressure Switch Connection
12	Call for Compressor Y1
13	Low Pressure Switch Connection
14	24VAC Power Common
15	Condensate Overflow Sensor
16	Dry Contact
17	UPM Ground Standoff

Fig. 43 — Unit Protection Module (UPM)

Safety controls include the following:

- High-pressure switch located in the refrigerant discharge line and wired across the HPC terminals on the UPM.
- Low-pressure switch located in the unit refrigerant suction line and wired across terminals LPC1 and LPC2 on the UPM board.
- UPM board dry contacts are normally open (NO).
- Water-side freeze protection sensor, mounted close to condensing water coil, monitors refrigerant temperature between condensing water coil and thermal expansion valve. If temperature drops below or remains at freeze limit trip for 30 seconds, the controller will shut down the compressor and enter a soft lockout condition. The default freeze limit trip is 26°F , however this can be changed to 15°F by cutting the R30 or Freeze1 resistor located on top of DIP switch SW1. Refer to Fig. 43, Item 3 for resistor location. If unit is employing a fresh water system (no anti-freeze protection), it is extremely important to have the Freeze1 R30 resistor set to 26°F in order to shut down the unit at the appropriate leaving water temperature and protect heat pump from freezing if a freeze sensor is included.

- Evaporator freeze protection sensor, mounted between the thermal expansion device and the evaporator, monitors refrigerant temperature between the evaporator coil and thermal expansion valve. If temperature drops below or remains at freeze limit trip for 30 seconds, the controller will shut down the compressor and enter into a soft lockout condition. The default freeze limit trip is 26°F. See Fig. 44 and 45.
- The condensate overflow protection sensor is located in the drain pan of the unit and connected to the 'COND' terminal on the UPM board.

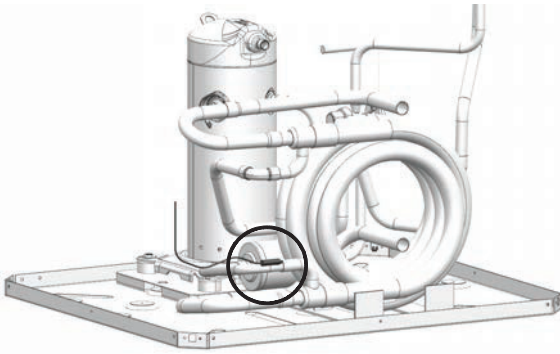

Fig. 44 — Waterside Freeze Protection Sensor

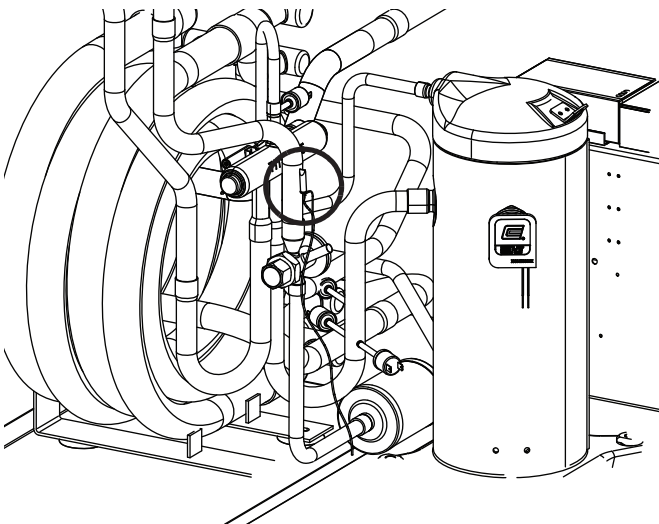

Fig. 45 — Air Coil Freeze Protection Sensor

The UPM board includes the following features:

Anti-short Cycle Timer

A 5-minute delay on break timer prevents compressor short cycling.

Random Start

Each controller has an unique random start delay ranging from 270 to 300 seconds on initial power up to reduce the chance of multiple units simultaneously starting at the same time after power up or after a power interruption, thus avoiding creating large in-rush current.

Low Pressure Bypass Timer

If the compressor is running and the low-pressure switch opens, the controller will keep the compressor ON for 120 seconds. After 2 minutes if the low-pressure switch remains open, the controllers will shut down the compressor and enter a soft lockout. The compressor will not be energized until the low-pressure switch closes and the anti-short cycle time delay expires. If the low-pressure switch opens 2 to 4 times in 1 hour, the unit will enter a hard lockout. In order to exit hard lockout power to the unit would need to be reset.

Brownout/Surge/Power Interruption Protection

The brownout protection in the UPM board will shut does the compressor if the incoming power falls below 18 VAC. The compressor will remain OFF until the voltage is above 18 VAC and ANTI-SHORT CYCLE TIMER (300 seconds) times out. The unit will not go into a hard lockout.

Malfunction Output

Alarm output is normally open (NO) dry contact. If pulse is selected the alarm output will be pulsed. The fault output will depend on the DIP switch setting for ALARM. If it is set to CONST, a constant signal will be produced to indicate a fault has occurred and the unit requires inspection to determine the type of fault. If it is set to PULSE, a pulse signal is produced and a fault code is detected by a remote device indicating the fault. The remote device must have a malfunction detection capability when the UPM board is set to PULSE.

LED Fault Indicator

The UPM includes an alarm indicator with blink codes to indicate a UPM fault. See Table 19.

Table 19 — UPM Board Fault Blink Codes

LED BLINKS	FAULT	FAULT CRITERIA
0	None	All fault conditions nominal
1	High Pressure	Refrigerant discharge pressure has exceeded 600 psig
2	Low Pressure	Refrigerant suction pressure has fallen below 40 psig
3	Water Coil Freeze Condition	Refrigerant temperature to water coil has fallen below 26°F for 30s
4	Condensate Overflow	Condensate levels in unit drain pan are too high
5	Brown Out	Control voltage has fallen below 18 vac
6	Air Coil Freeze Condition	Refrigerant temperature to the air coil has fallen below 26°F for 30s

Freeze Protection Sensors 1 and 2 (FP1 and FP2)

FP1 is located on the refrigerant liquid line between the TXV and the coaxial heat exchanger. If the temperature of the refrigerant entering the coaxial coil (heating mode) drops below or remains at 26°F (-6.6°C) for 30 seconds the UPM controller will shut down the compressor and enter into a soft lockout condition. Both the status LED and the Alarm contact will be active. The LED will flash three (3) times for this alarm condition. If this alarm occurs 2 times (or 4 times if the Lockout DIP switch is set to 4) within an hour the controller will enter into a hard lockout condition. The FP1 freeze limit trip can be lowered to 15°F (-9.4°C) by cutting the R30 sensor located near the top of DIP switch SW1. However, careful consideration should be given before cutting resistor R30. For example, if the unit is employing a fresh water system resistor R30 should remain to protect the coaxial heat exchanger from freezing and damaging the unit.

FP2 is located on the refrigerant liquid line between the TXV and the indoor coil. If the temperature of the refrigerant entering the indoor coil (cooling mode) drops below or remains at 26°F (-6.6°C) for 30 seconds the UPM controller will shut down the compressor and enter into a soft lockout condition. Both the status LED and the Alarm contact will be active. The LED will flash six (6) times for this alarm condition. If this alarm occurs 2 times (or 4 times if the Lockout DIP switch is set to 4) within an hour the controller will enter into a hard lockout condition. The FP2 freeze limit trip can be lowered to 15°F (-9.4°C) by cutting the R24 sensor located near the top of DIP switch SW1. However, careful consideration should be given before cutting resistor R24. For example, a low refrigerant temperature could cause frosting on the indoor coil, which restricts airflow causing the unit to malfunction.

Intelligent Reset

If a fault condition is initiated, the 5 minute delay on break time period is initiated and the unit will restart after these delays expire.

During this period the fault LED will indicate the cause of the fault. If the fault condition still exists or occurs 2 or 4 times (depending on 2 or 4 setting for LOCKOUT DIP switch) before 60 minutes, the unit will go into a hard lockout and requires a manual lockout reset. A single condensate overflow fault will cause the unit to go into a hard lockout immediately, and will require a manual lockout reset.

Lockout Reset

A hard lockout can be reset by turning the unit thermostat off and then back on when the RESET DIP switch is set to "Y" or by shutting off unit power at the circuit breaker when the RESET DIP switch is set to "R".

Selectable Alarm Mode

The UPM board can be configured to have either a constant or pulse signal. If constant (CONT) is selected the UPM will provide

a closed contact at the alarm output until the alarm is cleared. If pulsed (PULSE) is selected the UPM will sequence the alarm contact with the fault LED flashes.

Test Mode (TEST)

In test mode the ASC and Random Start time delays are reduced (5 seconds and 10 seconds respectively), and serve no function to the end user equipment. The alarm and display relays also pulse for both soft and hard lockout conditions, and are both cleared through a manual reset.

UPM Sequence of Operations

Figure 39 shows the UPM sequence of operations.

Freeze Protection Sensors

The control system employs 2 nominal 10,000 ohm thermistors (FP1 and FP2) that are used for freeze protection. Be sure FP1 is located in the discharge fluid and FP2 is located in the air discharge. See Fig. 46.

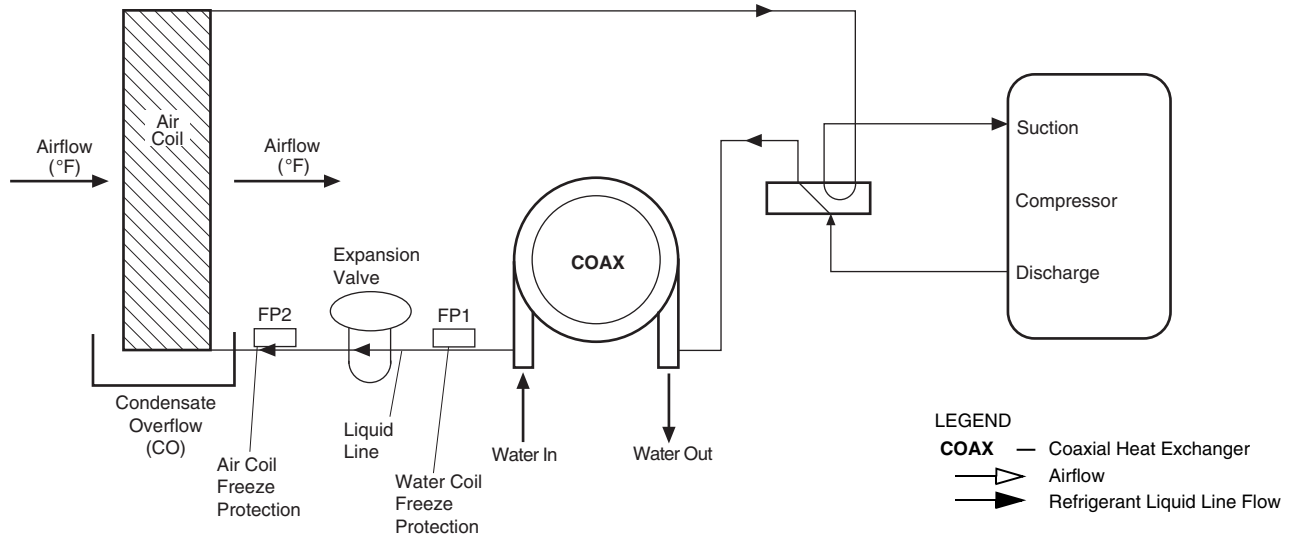

Fig. 46 — FP1 and FP2 Thermistor Location

Thermostatic Expansion Valves

Thermostatic expansion valves (TXV) are used as a means of metering the refrigerant through the evaporator to achieve a preset superheat at the TXV sensing bulb. Correct superheat of the refrigerant is important for the most efficient operation of the unit and for the life of the compressor.

Packaged heat pumps typically use one bi-flow TXV to meter refrigerant in both modes of operation. When diagnosing possible TXV problems it may be helpful to reverse the refrigerant flow to assist with the diagnosis.

Geothermal and water source heat pumps are designed to operate through a wide range of entering-water temperatures that will have a direct effect on the unit refrigerant operating pressures. Therefore, diagnosing TXV problems can be difficult.

TXV FAILURE

The most common failure mode of a TXV is when the valve fails while closed. Typically, a TXV uses spring pressure to close the valve and an opposing pressure, usually from a diaphragm, to open the valve. The amount of pressure exerted by the diaphragm will vary, depending on pressure inside of the sensing bulb. As the temperature of and pressure within the bulb decreases, the valve will modulate closed and restrict the refrigerant flow through the valve. The result is less refrigerant in the evaporator and an increase in the superheat. As the temperature at the bulb increases the diaphragm pressure will increase, which opens the valve and allows more refrigerant flow and a reduction in the superheat.

If the sensing bulb, connecting capillary, or diaphragm assembly are damaged, pressure is lost and the spring will force the valve to a closed position. Often, the TXV will not close completely so some refrigerant flow will remain, even if there is inadequate flow for the heat pump to operate.

The TXV sensing bulb must be properly located, secured, and insulated as it will attempt to control the temperature of the line to which it is connected. The sensing bulb must be located on a dedicated suction line close to the compressor. On a packaged heat pump, the bulb may be located almost any place on the tube running from the compressor suction inlet to the reversing valve. If the bulb is located on a horizontal section, it should be placed in the 10:00 or 2:00 position for optimal performance.

⚠ CAUTION

Use caution when tightening the strap. The strap must be tight enough to hold the bulb securely but caution must be taken not to over-tighten the strap, which could dent, bend, collapse or otherwise damage the bulb.

The bulb must be secured to the pipe using a copper strap. The use of heat transfer paste between the bulb and the pipe will also help ensure optimum performance.

The bulb must also be properly insulated to eliminate any influence on valve operation by the surrounding conditions. Cork tape is the recommended insulation as it can be molded tight to the bulb to prevent air infiltration.

Causes of TXV Failure

The most common causes of TXV failure are:

1. A cracked, broken, or damaged sensing bulb or capillary can be caused by excessive vibration of the capillary during shipping or unit operation.
If the sensing bulb is damaged or if the capillary is cracked or broken, the valve will be considered failed and must be replaced. Replacement of the TXV “power head” or sensing bulb, capillary, diaphragm assembly is possible on some TXVs. The power head assembly screws onto most valves, but not all are intended to be replaceable. If the assembly is not replaceable, replace the entire valve.

2. Particulate debris within the system can be caused by several sources including contaminated components, tubing, and service tools, or improper techniques used during brazing operations and component replacement.
Problems associated with particulate debris can be compounded by refrigerant systems that use POE (polyester oil). POE oil has solvent-like properties that will clean the interior surfaces of tubing and components. Particulates can be released from interior surfaces and may migrate to the TXV strainer, which can lead to plugging of the strainer.
3. Corrosive debris within the system may happen after a failure, such as a compressor burn out, if system was not properly cleaned.
4. Noncondensables may be present in the system. Non-condensables includes any substance other than the refrigerant or oil such as air, nitrogen, or water. Contamination can be the result of improper service techniques, use of contaminated components, and/or improper evacuation of the system.

Symptoms

The symptoms of a failed TXV can be varied and will include one or more of the following:

- Low refrigerant suction pressure
- High refrigerant superheat
- High refrigerant subcooling
- TXV and/or low pressure tubing frosting
- Equalizer line condensing and at a lower temperature than the suction line or the equalizer line frosting
- FP1 faults in the heating mode in combination with any of the symptoms listed above
- FP2 faults in the cooling mode in combination with any of the symptoms listed above. Some symptoms can mimic a failed TXV but may actually be caused by another problem.

Before conducting an analysis for a failed TXV the following must be verified:

- Confirm that there is proper water flow and water temperature in the heating mode.
- Confirm that there is proper airflow and temperature in the cooling mode.
- Ensure coaxial water coil is clean on the inside; this applies to the heating mode and may require a scale check.
- Refrigerant may be undercharged. To verify, subcooling and superheat calculations may be required.

Diagnostics

Several tests may be required to determine if a TXV has failed. The following tools may be required for testing:

1. Refrigerant gage manifold compatible with the refrigerant in the system.
2. Digital thermometer, preferably insulated, with wire leads that can be connected directly to the tubing.
3. Refrigerant pressure-temperature chart for the refrigerant used.

To determine that a TXV has failed, verify the following:

- The suction pressure is low and the valve is non-responsive.
- The TXV sensing bulb can be removed from the suction line and warmed by holding the bulb in your hand. This action should result in an increase in the suction pressure while the compressor is operating. The sensing bulb can also be chilled by immersion in ice water, which should result in a decrease in the suction pressure while the compressor is operating. No change in the suction pressure would indicate a nonresponsive valve.
- Simultaneous LOW suction pressure, HIGH refrigerant subcooling and HIGH superheat.

- LOW suction pressure, LOW subcooling and HIGH superheat may indicate an undercharge of refrigerant. HIGH subcooling and LOW superheat may indicate an overcharge of refrigerant. The suction pressure will usually be normal or high if there is an overcharge of refrigerant.
- LOW suction pressure and frosting of the valve and/or equalizer line may indicate a failed valve. However, these symptoms may also indicate an undercharge of refrigerant. Calculate the subcooling and superheat to verify a failed valve or refrigerant charge issue.

Repair

⚠ WARNING

Puron® refrigerant (R-410A) operates at higher pressure than R-22, which is found in other WSHPs. Tools such as manifold gages must be rated to withstand the higher pressures. Failure to use approved tools may result in a failure of tools, which can lead to severe damage to the unit, injury or death.

⚠ WARNING

Most TXVs are designed for a fixed superheat setting and are therefore considered non-adjustable. Removal of the bottom cap will not provide access for adjustment and can lead to damage to the valve or equipment, unintended venting of refrigerant, personal injury, or possibly death.

⚠ CAUTION

Always recover the refrigerant from the system with suitable approved tools, recovery equipment, and practices prior to attempting to remove or repair any TXV.

⚠ CAUTION

Use caution when tightening the strap. The strap must be tight enough to hold the bulb securely but caution must be taken not to over-tighten the strap, which could dent, bend, collapse or otherwise damage the bulb.

⚠ CAUTION

Puron® refrigerant (R-410A) requires the use of synthetic lubricant (POE oil). Do not use common tools on systems that contain R-22 refrigerants or mineral oil. Contamination and failure of this equipment may result.

IMPORTANT: Due to the hygroscopic nature of the POE oil in Puron refrigerant (R-410A) and other environmentally balanced refrigerants, any component replacement must be conducted in a timely manner using caution and proper service procedure for these types of refrigerants. A complete installation instruction will be included with each replacement TXV/filter drier assembly. It is of critical importance these instructions are thoroughly understood and carefully followed. Failure to follow these instructions can result in a system that is contaminated with moisture to the extent that several filter drier replacements may be required to properly dry the system.

IMPORTANT: Repair of any sealed refrigerant system requires training in the use of refrigeration tools and procedures. Repair should only be attempted by a qualified service technician. A universal refrigerant handling certificate will be required. Local and/or state license or certificate may also be required.

Figure 47 illustrates the typical refrigerant diagram for WSHP units.

See Table 20 for additional troubleshooting information.

⚠ CAUTION

Disconnect power from unit before removing or replacing connectors, or servicing motor. Wait 5 minutes after disconnecting power before opening motor.

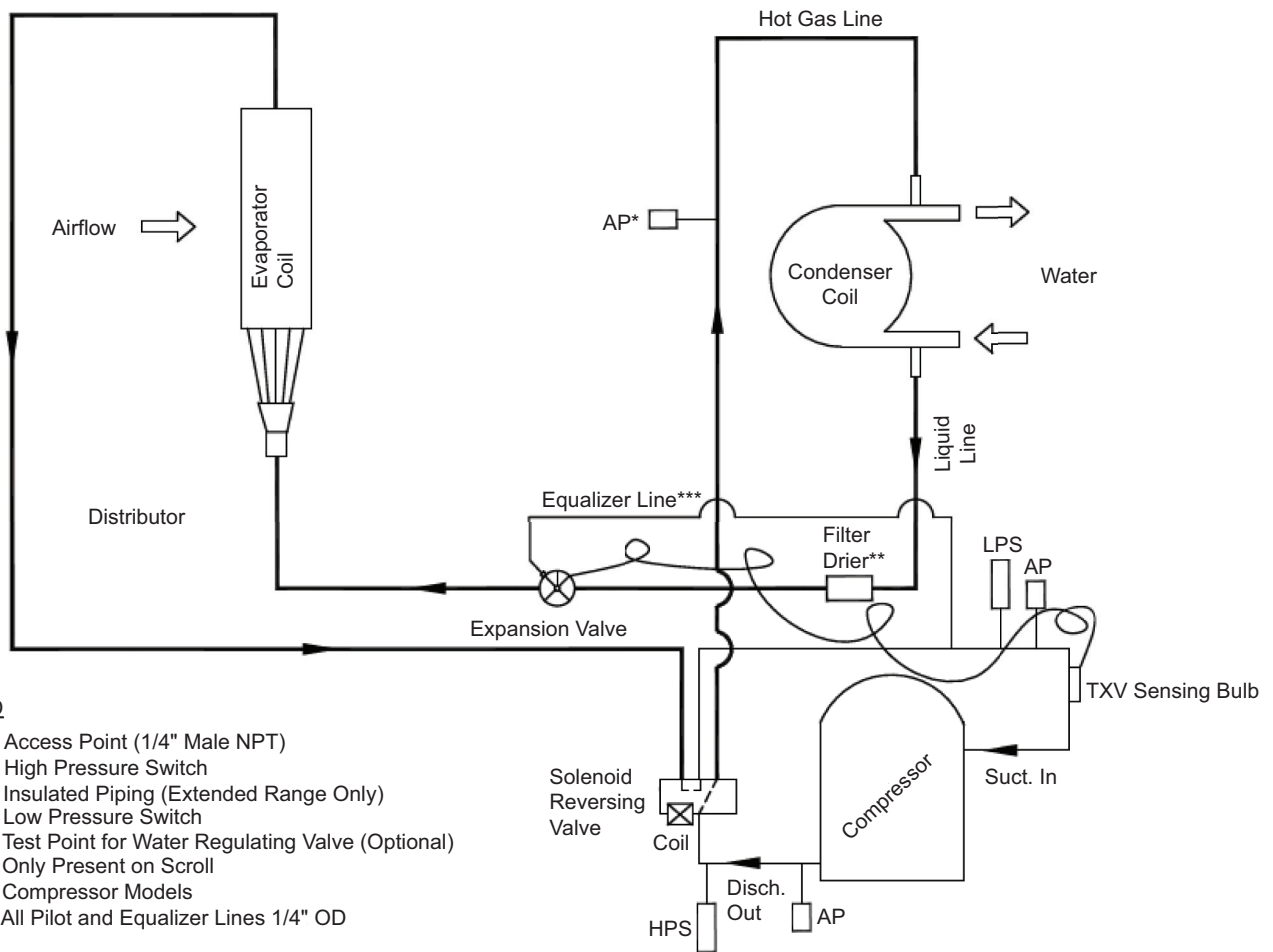

Fig. 47 — Typical Refrigerant Diagram

Table 20 — Troubleshooting

FAULT	COOLING	HEATING	CHECK	POSSIBLE CAUSE	SOLUTION				
No Compressor Operation but Fan Runs	X		Is fault LED Blinking 1 time?	High Pressure fault - no or low water flow	Check water valves and/or pumps for proper operation. Check for water coil blockage.				
				High Pressure fault - high water temperature	Check water temperature - is it in range?				
				High Pressure fault - fouled or scaled water coil	Check for proper flow rate and water temperature, but low water side temp rise in cooling.				
		X			High Pressure fault - no or low airflow	Check fan motor for proper operation. Check air filter. Inspect air coil for dirt/debris. Check ductwork - are dampers closed or blocked?			
					X		Is fault LED Blinking 2 times?	Low Pressure fault - no or low airflow	Check fan motor for proper operation. Check air filter. Inspect air coil for dirt/debris. Check ductwork - are dampers closed or blocked?
								Low Pressure fault - low refrigerant	Check refrigerant pressure with gage set.
			X	Is fault LED Blinking 3 times?	Freeze fault, water coil - no or low water flow	Check water valves and/or pumps for proper operation. Check for water coil blockage.			
					Freeze fault - low water temperature	Check water temperature - is it below 40°F entering? If heat pump is connected to a closed loop with antifreeze check that the "FREEZE 1" resistor on the UPM board has been cut to set the unit to antifreeze mode.			
					Freeze fault - low refrigerant	Check refrigerant pressure with gage set.			
	X			Is fault LED Blinking 4 times?	Condensate fault - poor drainage	Check condensate pan for high water level. Check drain line for blockages, double trapping or inadequate trapping.			
					Condensate fault - blocked return air	Check condensate pan for high water level. Check air filter and return air ductwork for blockage. Check that there is adequate space between the return air opening and walls or other obstructions on free return applications.			
	X	X		Is fault LED Blinking 5 times?	Brown out fault - low supply voltage	Check primary voltage - ensure it is within the limits listed on the unit data plate.			
					Brown out fault - overloaded control circuit	Check control voltage - if it is below 18 V check accessories connected to the unit and ensure that they do not exceed the VA draw shown on page 41.			
					Brown out fault - bad thermostat connection	Check that thermostat wiring is proper gage and length, that it is not damaged and that all connections at the thermostat and heat pump are secure.			
	X			Is fault LED Blinking 6 times?	Freeze fault, air coil - no or low airflow	Check fan motor for proper operation. Check air filter. Inspect air coil for dirt/debris. Check ductwork - are dampers closed or blocked?			
					Freeze fault, air coil - blocked return air	Check that there is adequate space between the return air opening and walls or other obstructions on free return applications.			
					Freeze fault, air coil - low refrigerant	Check refrigerant pressure with gage set.			
	X	X		No fault LED - contactor not energized	Thermostat not calling for compressor operation	Ensure that the thermostat is on and calling for "Y".			
					Bad thermostat connection	Check "Y" connection from thermostat. Ensure that there is 24 VAC between "Y" and "C".			
					Loose wire to contactor coil	Check wiring - ensure that there is 24 VAC across the contactor coil.			
Burned out contactor coil					Test contactor with 24VAC (between "R" and "C"). Ohm contactor coil - an open circuit indicates a burned coil.				
X	X		No fault LED - contactor energized	Open compressor overload	Check for supply voltage at the load side of the contactor. For 3 phase models check phase rotation and voltage at all 3 phases.				
				Poor wiring connections	Look for signs of heat on the wiring insulation. Check that all wiring connections are secure and properly torqued.				
				Burned out compressor	Does compressor hum when power is applied? If not check the resistance of the compressor windings using the values shown in the compressor characteristics chart. Note that the compressor must be cool (70°F) when checking the windings.				
No compressor or fan operation	X	X	Power LED on	Bad thermostat connection / faulty thermostat	Check thermostat and wiring. Check unit terminal block for 24 VAC between "Y" and "C" and "G" and "C".				
			Power LED off	Low or no supply power	Ensure that the supply voltage to the unit is with in the range shown on the unit data plate.				
				Faulty control transformer	Check for 24 VAC between "R" and "C" on the unit terminal block. For 75 and 100 VA transformers, check that the transformer circuit breaker has not tripped. Check low voltage circuit for overload conditions or short circuits before replacing the transformer.				

Table 20 — Troubleshooting (cont)

FAULT	COOLING	HEATING	CHECK	POSSIBLE CAUSE	SOLUTION
No fan operation (PSC motor)	X	X	Fan relay energized	Faulty motor	Check supply voltage from the fan relay to the motor. Check that all motor wires are secure. With power off spin the motor shaft - noise, resistance or uneven motion can be signs of motor failure.
			Fan relay not energized	No fan operation signal	Check for 24 VAC across the fan relay coil. Check all wiring connections.
				Bad fan relay	If the relay coil is energized but the relay does not pull in, check the resistance across the relay coil - an open circuit is an indicator of a faulty relay.
No fan operation (constant torque motor)	X	X		No fan operation signal	Check for 24 VAC between "G" and "C". Check all wiring connections.
				Loose wiring	Check all wiring connections at motor and control box.
				Faulty motor	Check supply voltage to the motor. Check that all motor wires are secure. With power off spin the motor shaft - noise, resistance or uneven motion can be signs of motor failure.
No fan operation (constant airflow motor)	X	X		No fan operation signal	Check for 24 VAC between "G" and "C". Check all wiring connections. Make sure that the thermostat connection plug is securely connected.
				Loose wiring	Check all wiring connections at motor and control box. Check that power and control harnesses are securely connected.
				Interface board problems	Make sure that the interface board is not damaged and that all DIP switches are in the proper configuration (refer to the blower performance tables).
				Faulty motor	Check supply voltage to the motor. Check that all motor wires are secure. Move the "TEST" DIP switch to "ON" and the other switches to "OFF" on the "ADJUST" switch block on the interface board - the motor should run at 70% torque when "G" is called. With power off spin the motor shaft - noise, resistance or uneven motion can be signs of motor failure.
Unit not shifting into cooling	X		Reversing valve solenoid energized	Faulty solenoid	Check that the reversing valve solenoid is receiving 24 VAC. If so, check the resistance of the solenoid - an open circuit may indicate a burned out solenoid.
			Reversing valve solenoid not energized	Miswired/faulty thermostat	Check that the reversing valve thermostat wire is connected to the "O" terminal of the thermostat. Check for a contact closure between "O" and "R".
				Loose wire on "O" terminal	Check that the wires from the thermostat to the unit are securely connected and that the wires from the electrical box to the reversing valve are connected.
Excessively cold supply air temperature in cooling or excessively hot supply air temperature in heating	X	X	Reduced airflow	Dirty Filter	Replace filter.
				Fan speed too low	Consult blower performance table and increase fan speed if possible.
				Excessive duct pressure drop	Consult blower performance table and increase fan speed if possible.
Excessively warm supply air temperature in cooling and/or excessively cool air in heating	X	X	Airflow too high	Fan speed setting too high	Consult blower performance table and reduce fan speed if possible.
			High or low water temperature	Inlet water temperature out of range	Check unit capacity vs. water temperature.
			Air leakage	Leaky ductwork	Inspect ductwork.
			Loss of refrigeration capacity	Low refrigerant	Check refrigerant pressures with gage set.
High humidity	X		Airflow too high	Fan speed setting too high	Consult blower performance table and reduce fan speed if possible.
			Loss of refrigeration capacity	Low refrigerant	Check refrigerant pressures with gage set.
			Short cycling	Unit oversized	Check unit performance against building load calculations.
Poor thermostat location	Make sure that thermostat is not located by a supply- air duct.				
Objectionable noise levels	X	X	Air noise	Poor ductwork/grille design	Ensure ductwork and grilles are properly sized for unit airflow.
				Fan speed setting too high	Consult blower performance table and reduce fan speed if possible.
			Structure Bourne noise	Unit not mounted on full vibration pad	Mount unit on a vibration pad.
				Unit not connected with flexible conduit, water lines and/or ductwork	Install unit in accordance with instructions.
	X		Compressor noise	Unit cabinet touching wall or other building component	Adjust unit location to avoid unit touching structure.
				High water temperature or low water flow rate elevating head pressure	Increase water flow rate and/or reduce water temperature if possible.
				Scaled or fouled water coil elevating heat pressure	Clean/descale water coil.
	X		Low airflow elevating head pressure	Check filter. Increase fan speed.	
X	X	Water hammer	Fast closing valves installed	Change valves to slow-close type.	

50PSH,PSV START-UP CHECKLIST
(Remove and use for job file.)

NOTE: To avoid injury to personnel and damage to equipment or property when completing the procedures listed in this start-up checklist, use good judgment, follow safe practices, and adhere to the safety considerations/information as outlined in preceding sections of this Installation, Start-Up, and Service Instructions document.

CUSTOMER: _____ JOB NAME: _____
 MODEL NO.: _____ SERIAL NO.: _____ DATE: _____

I. PRE-START-UP

- Does the unit voltage correspond with the supply voltage available? (Y/N) _____
- Have the power and control wiring connections been made and terminals tight? (Y/N) _____
- Have water connections been made and is fluid available at heat exchanger? (Y/N) _____
- Has pump been turned on and are isolation valves open? (Y/N) _____
- Has condensate connection been made and is a trap installed? (Y/N) _____
- Is an air filter installed? (Y/N) _____

II. START-UP

- Is fan operating when compressor operates? (Y/N) _____
- If 3-phase scroll compressor is present, verify proper rotation per instructions. (Y/N) _____

UNIT VOLTAGE — COOLING OPERATION

Phase AB Volts _____	Phase BC Volts _____	Phase CA Volts _____
	(if 3 phase)	(if 3 phase)
Phase AB Amps _____	Phase BC Amps _____	Phase CA Amps _____
	(if 3 phase)	(if 3 phase)

CONTROL VOLTAGE

- Is control voltage above 21.6 volts? (Y/N) _____.
- If not, check for proper transformer connection.

TEMPERATURES

Fill in the analysis chart attached.

COAXIAL HEAT EXCHANGER	COOLING CYCLE:	FLUID IN _____ F	FLUID OUT _____ F	_____ PSI	_____ FLOW
	HEATING CYCLE:	FLUID IN _____ F	FLUID OUT _____ F	_____ PSI	_____ FLOW
AIR COIL	COOLING CYCLE:	AIR IN _____ F	AIR OUT _____ F		
	HEATING CYCLE:	AIR IN _____ F	AIR OUT _____ F		

HEATING CYCLE ANALYSIS

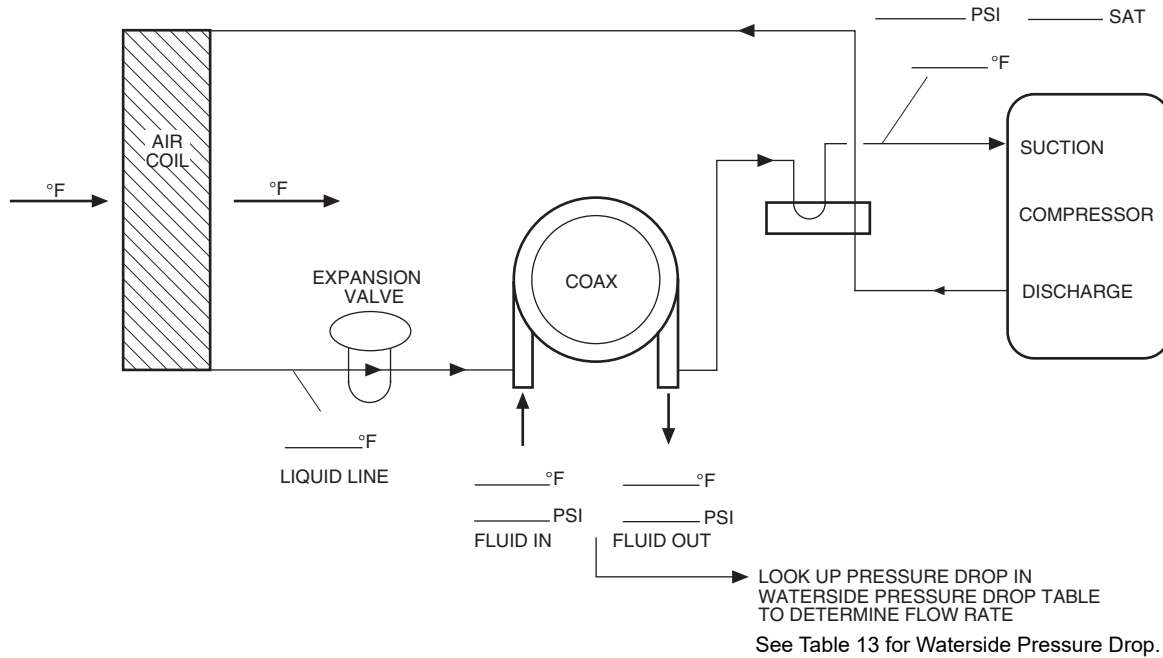

COOLING CYCLE ANALYSIS

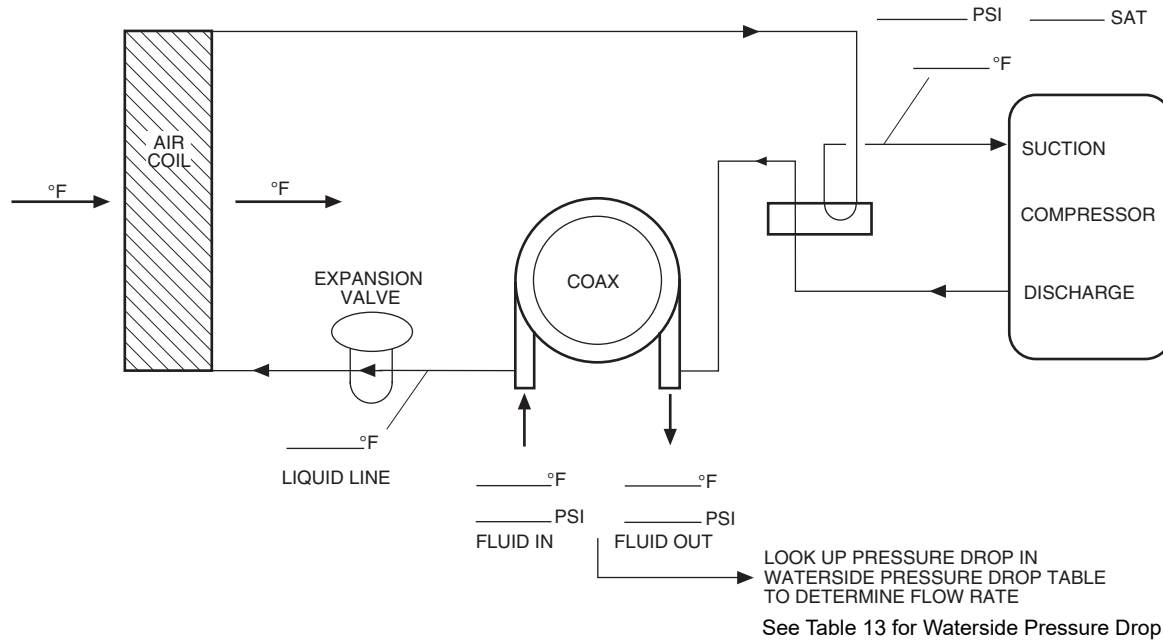

HEAT OF EXTRACTION (ABSORPTION) OR HEAT OF REJECTION =

$$\text{FLOW RATE (GPM)} \times \text{TEMP. DIFF. (DEG. F)} \times \text{FLUID FACTOR}^* = \text{Btu/hr}$$

SUPERHEAT = SUCTION TEMPERATURE – SUCTION SATURATION TEMPERATURE
= _____ (DEG F)

SUBCOOLING = DISCHARGE SATURATION TEMPERATURE – LIQUID LINE TEMPERATURE
= _____ (DEG F)

*Use 500 for water, 485 for antifreeze.