

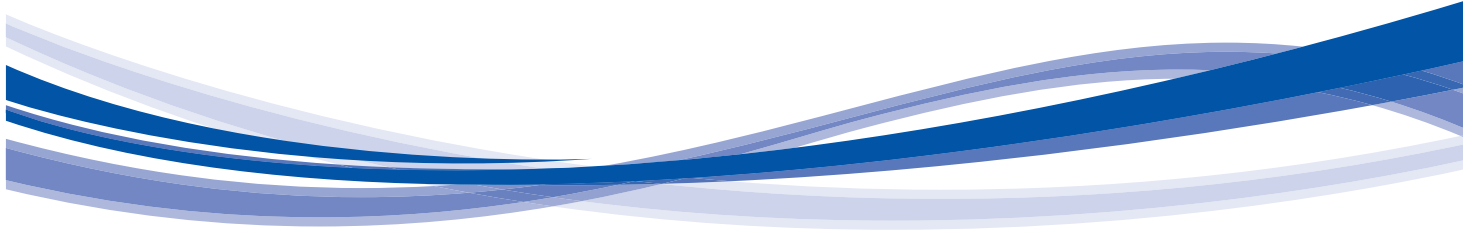

Product Data

Aquazone™ Single-Stage Water Source Heat Pumps

1/2 to 6 Nominal Tons



50PSH, PSV007-070
Single-Stage Water Source Heat Pumps
with Puron® Refrigerant (R-410A)

The Aquazone single-stage water source heat pump with Puron refrigerant (R-410A) is a high quality, efficient solution for all boiler/tower and geothermal applications.

Single-package horizontally and vertically mounted water source heat pumps with electronic controls offer:

- Electronically commutated motor (ECM) blower motor option
- Mute package and closed cell foam insulation for quieter operation available
- Versatility: apply to commercial boiler/cooling tower or geothermal applications (select extended range option for use in geothermal applications)
- Performance certified to AHRI/ISO 13256-1
- Flexible and reliable multiple protocol WSHP Open controller can use BACnet¹, Modbus², N2, and LonWorks³ (with a separate card) protocols for integrating energy efficiency and precise unit control
- Hot gas reheat (HGRH) available for dehumidification capability
- Optional tin-plated copper tubing and polymer coated aluminum fin evaporator coil available
- Non-ozone depleting Puron refrigerant (R-410A)

Operating efficiency

Carrier water source heat pumps (WSHPs) are designed for quality and high performance over a lifetime of operation.

All efficiencies stated are in accordance with standard conditions under ISO (International Organization for Standardization) Standard 13256-1:1998 and provide among the highest ratings in the industry, exceeding ASHRAE (American Society of Heating, Refrigerant and Air-Conditioning Engineers) 90.1 Energy Standards.

High quality construction and testing

All units are manufactured to meet extensive quality control protocol from start to finish through an automated control system, which provides continuous monitoring of each unit and performs quality

1. BACnet is a trademark of ASHRAE.
2. Modbus is a registered trademark of Schneider Electric.
3. LonWorks is a registered trademark of Echelon Corporation.

control checks as equipment progresses through the production process. Standard construction features of the Aquazone™ units include:

Cabinet

Standard unit fabrication consists of heavy gage galvanized sheet metal cabinet construction designed for part standardization (i.e., minimal number of parts) and modular design.

All interior surfaces are lined with 1/2 in. thick, 1-1/2 lb per cubic ft density, thermal insulation. This insulation is non-combustible, non-hydroscopic and does not support fungal growth. Insulation meets NFPA90A and 90B for fire protection and is certified to meet the Greenguard Indoor Air Quality Standard for Low Emitting Products.

Protection against corrosion is a feature in the 50PS series. A stainless steel drain pan is designed to last the lifetime of the unit and resist corrosion and cracking that may occur with steel or plastic materials.

Compressor

Aquazone 50PS single-stage units include a rotary compressor in sizes 007-018 and a scroll compressor in sizes 024-070. Single-stage models with Puron® refrigerant (R-410A) offer a dual level vibration isolation system. The compressor has thermal overload protection and is located in an insulated compartment away from the airstream to minimize sound transmission.

AHRI/ISO labels

Aquazone units have AHRI (Air-Conditioning, Heating, and Refrigeration Institute)/ISO, NRTL (Nationally Recognized Testing Lab), or ETL labels and are factory tested under normal operating conditions at nominal water flow rates.

Blower and motor assembly

Large blower wheels allow the unit to operate at lower speeds for quieter operation.

Permanent split capacitor (PSC) blower motors are standard on unit sizes 1/2 through 1 ton. Constant torque ECM are standard on unit sizes 1-1/4 through 6 tons offering up to 3 speeds. Constant airflow ECMs are optional on units, allowing the user to select the correct speed to deliver the specified airflow and the design system static pressure.

Motors are mounted on the fan housing with rubber grommets to prevent noise and vibration transmission to the unit and airstream.

A 1-in. supply air duct-flange connection is standard, facilitating duct installation on the unit. Horizontal units are field convertible from straight through to an end discharge arrangement.

Refrigeration/water circuit

All units contain sealed Puron refrigerant (R-410A) circuits including a high-efficiency hermetic compressor designed for heat pump operation, a thermostatic expansion valve for refrigerant metering, an enhanced corrugated aluminum-lanced fin and rifled copper tube refrigerant-to-air heat exchanger, reversing valve, coaxial (tube-in-tube) refrigerant-to-water heat exchanger, and safety controls including a high-pressure switch, low-pressure switch, water coil low temperature sensor, and air coil low temperature sensor.

Quiet operation

All panels are insulated with 1/2 in. thick, 1-1/2 lb per cubic ft density fiberglass insulation for better thermal

Table of contents

	Page
Features/Benefits	2
Model Number Nomenclature	5
AHRI/ISO Capacity Ratings	6
Physical Data	7
Options and Accessories	8
Dimensions	12
Performance Data	15
Electrical Data	18
Application Data	22
Controls	27
Guide Specifications	32

insulation and noise reduction. All units have a unique floating basepan where the compressor and condenser are mounted on a heavy steel plate that rests on a high density rubber pad in the base of the unit. In addition, compressors are mounted on rubber grommets. This double isolation is standard on all units preventing vibration and noise transmission from the compressor to the unit structure.

Fan motor insulation and double isolated compressor are provided for sound isolation, cabinets are fully insulated to reduce noise transmission, low speed blowers are utilized for quiet operation through reduced outlet air velocities, and air-to-refrigerant coils are designed for lower airflow coil face velocities. Additional sound mitigation can be attained with the mute package option.

Puron® refrigerant (R-410A)

Puron refrigerant (R-410A) is a non-chlorine based environmentally balanced, non-ozone depleting refrigerant. Puron refrigerant characteristics, compared to R-22, have:

- Binary and near azeotropic mixture of 50% R-32 and 50% R-125.
- Higher efficiencies (50 to 60% higher operating pressures).
- Virtually no glide. Unlike other alternative refrigerants, the two components in Puron refrigerant have virtually the same leak rates. Therefore, refrigerant can be added if necessary without recovering the charge.

Optional air coil protection

All units come standard with a copper tube, aluminum fin evaporator coil. These evaporator coils employ lanced fin and rifled tubing for maximum heat transfer. Large face areas result in lower face velocity reducing sound while ensuring high latent heat removal for maximum dehumidification in the cooling mode.

Optional tin electro-plated copper tubing with high-tech polymer coated aluminum fins protect the air coil from all forms of corrosive elements in the airstream. Corrosion often results in refrigerant leaks and eventual failure of the air coil costing hundreds of dollars to replace. Studies have also shown that these air coil coatings improve moisture shedding and therefore improve a units moisture removal capability resulting in a more comfortable indoor environment. The 50PSH and PSV units assure both maximum air coil life and comfort.

Design flexibility

Airflow configurations for horizontal units are available in four patterns including left or right return, and left, right, or back discharge. Horizontal units are field convertible from left or right discharge to back discharge. Vertical units are available in three airflow patterns including top discharge with right or left return. Standard entering water temperature is between 50 and 100°F. Extended entering water temperature range between 25 and 110°F offers maximum design flexibility for all applications. Water flow rates as low as 1.5 gpm per ton assist with selection from a various range of circulating pumps. Factory-installed options are offered to meet specific design requirements.

Safe, reliable operation

Standard safety features for the refrigerant circuit include high-pressure switch, low-pressure sensor to detect loss of refrigerant, and low air temperature sensor to safeguard against freezing. Equipment safety features include water loop temperature monitoring, voltage protection, water coil freeze protection, and standard electronic condensate overflow shutdown. All safety features are tested and run at the factory to assure proper operation of all components and safety switches.

All components are carefully designed and selected for endurance durability, and carefree day-to-day operation.

The Aquazone™ unit is shipped to provide internal and external equipment protection. Shipping supports are placed under the blower housing and compressor feet. In addition, both horizontal and vertical units are mounted on oversized pallets with lag bolts for sturdiness and maximum protection during transit.

Ease of installation

The Aquazone unit is packaged for simple low cost handling, with minimal time required for installation. All units are pre-wired and factory charged with refrigerant. Horizontal units are provided with factory-installed hanger isolation brackets. Water connections and condensate drains are anchored securely to the unit cabinet, eliminating the need for backup wrenches.

Simple maintenance and serviceability

The Aquazone water source heat pump (WSHP) units are constructed to provide ease of maintenance. Units allow access to the compressor section from 2 sides and have large removable panels for easy access. Additional panels are provided to access the blower and control box sections.

The blower housing assembly can be serviced without disconnecting ductwork from the dedicated blower access panel. Blower units are provided with permanently lubricated bearings for worry-free performance. Blower inlet rings allow removal of the blower wheel without having to remove the housing or ductwork connections.

Electrical disconnection of the blower motor and control box is easily accomplished from quick disconnects on each component.

Easy removal of the control box from the unit provides access to all refrigeration components.

The refrigeration circuit is easily tested and serviced through the use of high and low pressure ports integral to the refrigeration circuit.

Maximum control flexibility

Aquazone water source heat pumps provide reliable control operation using a standard microprocessor board with flexible alternatives for many direct digital controls (DDC) applications including the open protocol systems.

The Aquazone standard unit solid-state control system, Unit Protection Module (UPM), provides control of the unit compressor, reversing valve, fan, safety features, hot gas reheat, and troubleshooting fault indication features. The UPM is a user friendly, low cost, advanced WSHP control board with inputs for either thermostat control or DDC control. Many features are field selectable to maximize flexibility in field installation. The overall features of this standard control system include:

75-va transformer

The transformer assists in accommodating accessory loads.

Anti-short cycle timer

The timer provides a minimum off time to prevent the unit from short cycling. The 5-minute timer energizes when the compressor is deenergized, resulting in a 5-minute delay before the unit can be restarted.

Random start relay

The random start relay provides a random delay in energizing each different WSHP unit. This option minimizes peak electrical demand during start-up from different operating modes or after building power outages.

High and low pressure refrigerant protection

This protection safeguards against unreliable unit operation and provides a warning for refrigerant leaking.

Condensate overflow sensor

The condensate overflow sensor is standard on all units. The electronic sensor is mounted to the drain pan. When condensate pan liquid reaches an unacceptable level, unit is automatically deactivated and placed in a lockout condition. Thirty continuous seconds of overflow is recognized as a fault by the sensor.

High and low voltage protection

Safety protection for excessive or low voltage conditions is included.

Automatic intelligent reset

The unit will automatically restart 5 minutes after shutdown if the fault has cleared. Should a fault occur 3 times sequentially, lockout will occur.

Low pressure bypass timer

The low pressure switch is bypassed for 120 seconds after it opens to prevent nuisance low pressure lockouts during cold start-up in the heating mode.

Water coil freeze protection (selectable for water or antifreeze)

The field selectable switch for water and water/glycol solution systems initiates a fault when temperatures exceed the selected limit for 30 continuous seconds.

Alarm relay setting

A selectable 24-v or pilot duty dry contact provides activation of a remote alarm.

Service Test mode with diagnostic LED (light-emitting diode)

The Service Test mode allows service personnel to check the operation of the WSHP and control system efficiently. Upon entering Service Test mode, time delays are sped up, and the Status LED will flash a code to indicate the last fault experienced for easy diagnosis. Based on the fault code flashed by the status LED, system diagnostics are assisted through the use of Carrier-provided troubleshooting tables for easy reference to typical problems.

LED visual output

An LED panel indicates high pressure, low pressure, low voltage, high voltage, air/water freeze protection, condensate overflow, and control status.

Model number nomenclature



50PSH,PSV Premium Efficiency

50PSH 024 H C C 6 A C C X

Aquazone™ Single Stage Water Source Heat Pump with Puron® Refrigerant (R-410A)

50PSH – Horizontal Configuration
50PSV – Vertical Upflow Configuration

Size – Nominal Tons

007 – 1/2 018 – 1-1/2 042 – 3-1/2
009 – 3/4 024 – 2 048 – 4
012 – 1 030 – 2-1/2 060 – 5
015 – 1-1/4 036 – 3 070 – 6

Airflow Configuration

Horizontal

Option	Return	Discharge	Blower Motor
B	Right	Back	PSC
C	Right	Left (Straight)	Constant Torque ECM
E	Left	Back	PSC
H	Left	Right	Constant Torque ECM
M	Right	Back	Constant Torque ECM
N	Right	Left (Straight)	Constant Airflow ECM
P	Right	Back	Constant Airflow ECM
S	Left	Right	PSC
T	Left	Back	Constant Torque ECM
W	Left	Right (Straight)	Constant Airflow ECM
Y	Left	Back	Constant Airflow ECM
Z	Right	Left (Straight)	PSC

Vertical

Option	Return	Discharge	Blower Motor
D	Right	Top	Constant Torque ECM
J	Left	Top	Constant Airflow ECM
K	Right	Top	Constant Airflow ECM
L	Left	Top	PSC
R	Right	Top	PSC
Z	Left	Top	Constant Torque ECM

Control

C – Complete C Microprocessor Control Package
D – Deluxe D Microprocessor Control Package
W – WSHP Open Multi-Protocol Control

Refrigerant Circuit Options

Option	Non-Coated Air Coil		Coated Air Coil	
	Copper	Cupronickel	Copper	Cupronickel
Standard	C	N	A	J
Hot Gas Reheat	E	P	D	F
Hot Gas Bypass	T	S	U	W
Hot Water Generator	B	G	H	K
Hot Gas Bypass and Reheat	L	M	R	V

LEGEND

ECM — Electronically Commutated Motor
PSC — Permanent Split Capacitor

Factory Installed Options			
Electric Heat	Std Filter	MERV8 Filter	MERV13 Filter
None	X	Y	Z
5 kW Electric Heat	A	B	W
10 kW Electric Heat	C	F	R
15 kW Electric Heat	D	G	S
20 kW Electric Heat	E	T	H

Operating Range/Sound Option/Insulation

Insulation	Standard Range		Extended Range	
	Std	Mute	Std	Mute
Standard	C	N	A	J
1/2 in. Closed Cell Foam	E	P	D	F

Valve Options

A – 2-Way Solenoid
B – Automatic Flow Regulating Valve
C – None
D – 2-way Solenoid with Automatic Flow Regulating Valve

Revision Code

A – Current Revision

Voltage

0 – 115-1-60
3 – 208/230-1-60
4 – 265-1-60
5 – 208/230-3-60
6 – 460-3-60
B – 115-1-60 with Disconnect
C – 208/230-1-60 with Disconnect
D – 265-1-60 with Disconnect
E – 208/230-3-60 with Disconnect
F – 460-3-60 with Disconnect

NOTE: 4-Wire Design (L1, L2, L3, N) is required on 460V 3-Phase units with Constant Airflow ECM Motor.

PSC Motor^a

50PS UNIT SIZE	FLUID FLOW RATE (gpm)	Air Flow Rate (cfm)	WATER LOOP HEAT PUMP				GROUND WATER HEAT PUMP				GROUND LOOP HEAT PUMP			
			Cooling 86°F		Heating 68°F		Cooling 59°F		Heating 50°F		Cooling 77°F		Heating 32°F	
			Capacity (Btuh)	EER	Capacity (Btuh)	COP	Capacity (Btuh)	EER	Capacity (Btuh)	COP	Capacity (Btuh)	EER	Capacity (Btuh)	COP
07	2.0	300	6,800	15.70	8,600	5.70	8,400	25.10	6,900	4.70	7,400	18.50	5,100	3.55
09	2.5	325	8,900	14.35	11,200	5.30	10,500	24.35	9,000	4.50	9,500	17.05	6,800	3.60
12	4.0	400	12,200	14.90	14,600	5.00	14,200	22.70	12,000	4.30	12,600	17.50	9,300	3.60

NOTE(S):

a. Certified in accordance with AHRI/ISO 13256-1.

LEGEND

AHRI — Air-Conditioning, Heating and Refrigeration Institute
COP — Coefficient of Performance
db — Dry Bulb
EER — Energy Efficiency Ratio
ISO — International Organization for Standardization
wb — Wet Bulb



ECM Motor (Constant Torque and Constant Airflow)^a

50PS UNIT SIZE	FLUID FLOW RATE (gpm)	Air Flow Rate (cfm)	WATER LOOP HEAT PUMP				GROUND WATER HEAT PUMP				GROUND LOOP HEAT PUMP			
			Cooling 86°F		Heating 68°F		Cooling 59°F		Heating 50°F		Cooling 77°F		Heating 32°F	
			Capacity (Btuh)	EER	Capacity (Btuh)	COP	Capacity (Btuh)	EER	Capacity (Btuh)	COP	Capacity (Btuh)	EER	Capacity (Btuh)	COP
15	4.0	500	15,100	16.55	16,700	5.21	17,000	27.25	13,000	4.28	16,200	19.80	11,000	3.63
18	5.0	600	19,500	15.90	21,300	5.00	21,300	25.30	17,700	4.40	20,500	18.50	14,800	3.70
24	6.0	850	24,500	16.95	28,500	5.15	28,400	27.35	23,700	4.50	26,000	19.80	18,000	3.70
30	7.0	1000	27,000	16.60	31,000	5.70	31,000	27.00	25,000	4.95	28,500	19.40	20,300	3.95
36	10.0	1200	36,000	17.10	41,000	5.50	40,200	25.90	34,400	4.90	37,500	19.70	26,000	3.90
42	10.5	1400	38,400	15.20	42,400	5.50	44,100	25.60	35,000	4.65	40,600	19.40	26,800	3.70
48	12.0	1600	44,400	15.00	50,000	5.25	51,100	24.00	40,500	4.30	46,800	17.75	33,400	3.70
60	15.0	2000	58,900	14.95	69,800	5.09	66,500	23.25	56,700	4.85	61,500	17.45	46,900	4.05
70	17.0	2200	68,000	16.20	86,000	5.60	71,400	22.40	71,400	5.00	70,500	18.50	56,500	4.20

NOTE(S):

a. Certified in accordance with AHRI/ISO 13256-1.

LEGEND

AHRI — Air-Conditioning, Heating and Refrigeration Institute
COP — Coefficient of Performance
db — Dry Bulb
EER — Energy Efficiency Ratio
ISO — International Organization for Standardization
wb — Wet Bulb



Physical Data 007-024

50PS UNIT SIZE	007	009	012	015	018	024
Compressor Type	Rotary					Scroll
Maximum Water Working Pressure (psig)	400 ^a					
Standard Fan Motor and Blower						
Fan Motor Type	PSC			ECM Constant Torque		
Fan Motor (hp)	1/10	1/10	1/10	1/3	1/3	1/2 ^b / 1/3
Blower Wheel Size (Diameter x Width) (in.)	4.5 x 4.5	4.5 x 4.5	5.5 x 5.5	5.5 x 4.5	9 x 7	9 x 7
ECM Const CFM Fan Motor						
Fan Motor Type	NA	NA	NA	ECM Constant CFM		
Fan Motor (hp)	NA	NA	NA	1/3	1/3	1/3
Water Connection Size						
FPT (in.)	3/4	3/4	3/4	3/4	3/4	3/4
Coaxial Coil Volume (gal.)	0.15	0.15	0.31	0.31	0.31	0.48
Vertical Cabinet						
Refrigeration Charge (oz)	31	31	30	46	34	65
Air Coil Dimensions (H x L) (in.)	12 x 16.5	12 x 16.5	16 x 16.5	16.5 x 20	16.5 x 20	24 x 21
Standard Filter - 1-in. Throwaway (H x L) (in.)	15 x 20	15 x 20	18 x 20	20 x 20	20 x 20	24 x 24
Operating Weight (lb)	140	154	166	191	195	229
Shipping Weight (lb)	160	174	186	208	212	242
Horizontal Cabinet						
Refrigeration Charge (oz)	31	31	35	35	35	65
Air Coil Dimensions (H x L) (in.)	12 x 16.5	12 x 16.5	16 x 16.5	18 x 18.5	18 x 18.5	18 x 28
Standard Filter - 1-in. Throwaway (H x L) (in.)	15 x 20	15 x 20	18 x 20	18 x 20	18 x 20	20 x 30
Operating Weight (lb)	165	172	173	190	198	307
Shipping Weight (lb)	185	192	205	218	222	340

Physical Data 030-070

50PS UNIT SIZE	030	036	042	048	060	070
Compressor Type	Scroll					
Maximum Water Working Pressure (psig)	400 ^a					
Standard Fan Motor and Blower						
Fan Motor Type	ECM Constant Torque					
Fan Motor (hp)	1/2	3/4	3/4	3/4	1	1
Blower Wheel Size (Diameter x Width) (in.)	9 x 7	9 x 7	10 x 8	10 x 8	11 x 9	11 x 9
ECM Const CFM Fan Motor						
Fan Motor Type	ECM Constant CFM					
Fan Motor (hp)	1/2	3/4	3/4	3/4	1	1
Water Connection Size						
FPT (in.)	1	1	1	1	1	1
Coaxial Coil Volume (gal.)	0.39	0.62	0.62	0.62	0.62	0.85
Vertical Cabinet						
Refrigeration Charge (oz)	71	65 Cu / 68 CuNi	83 Cu / 86 CuNi	83 Cu / 86 CuNi	90 Cu / 93 CuNi	127
Air Coil Dimensions (H x L) (in.)	24 x 27	24 x 27	32 x 27	32 x 27	40 x 27	40 x 27
Standard Filter - 1-in. Throwaway (H x L) (in.)	24 x 30	24 x 30	16 x 30 (2)	16 x 30 (2)	20 x 30 (2)	20 x 30 (2)
Operating Weight (lb)	269	281	334	340	396	444
Shipping Weight (lb)	292	304	360	366	422	470
Horizontal Cabinet						
Refrigeration Charge (oz)	71	65 Cu / 68 CuNi	83 Cu / 86 CuNi	83 Cu / 86 CuNi	90 Cu / 93 CuNi	127
Air Coil Dimensions (H x L) (in.)	20 x 32.5	20 x 32.5	20 x 43.25	20 x 43.25	20 x 54	20 x 54
Standard Filter - 1-in. Throwaway (H x L) (in.)	20 x 34.5	20 x 34.5	20 x 24 (2)	20 x 24 (2)	20 x 28 (2)	20 x 28 (2)
Operating Weight (lb)	358	369	400	405	452	494
Shipping Weight (lb)	404	415	465	470	520	562

NOTE(S):

- a. 300 psig when unit is built with the 2-way solenoid valve option.
- b. 2 ton units at 460v and Constant Torque ECM motor will have a 1/2 HP fan motor rather than a 1/3 HP motor.

LEGEND

- ECM — Electronically Commutated Motor
- NA — Not Applicable
- PSC — Permanent Split Capacitor

ITEM	FACTORY-INSTALLED OPTION	FIELD-INSTALLED ACCESSORY
Cupronickel Heat Exchanger	X	
Sound Attenuation Package	X	
Extended Range Units	X	
Hot Water Generator Coil	X	
Hot Gas Reheat	X	
Hot Gas Bypass	X	
Autoflow Regulator	X	
Two-Way Solenoid Control Valve	X	
Fan Motor Options	X	
Air Coil Protection	X	
Electric Heater	X	
Deluxe D Control Package	X	
WSHP Open Multi-Protocol Controller	X	
WSHP Open Equipment Touch™ Device		X
WSHP Open System Touch™ Device		X
WSHP Open ZS Sensor		X
Supply and Return Water Hose Kits		X
Electric Duct Heaters		X
Carrier Non-Communicating Thermostat		X

Factory-installed options

Cupronickel heat exchangers

Cupronickel heat exchangers are available for higher corrosion protection for applications such as open tower, geothermal, etc. Consult the water quality guidelines for proper application and selection of this option.

Sound attenuation options (mute and closed cell foam)

The mute package is available on unit sizes 024 and up and includes a compressor sound blanket. The closed cell foam insulation option is available on all sizes and features acoustical foam insulation that attenuates the compressor and fan sound.

Extended range units

These units have an insulated coaxial coil and insulated refrigerant and water piping to prevent condensation, and therefore potential dripping problems, in applications where the entering water temperature is below the normal operating range (less than 50°F). Units are capable of operating with an entering water temperature range of 25 to 110°F.

Hot water generator coil

The hot water generator coil is available to generate hot water in the range of 110 to 140°F. Coil is installed off of the discharge line from the compressor to provide heat for a domestic water supply. The coil is a vented, double wall coil, and also includes a circulating pump, high water temperature limit switch (set at 140°F), discharge gas temperature limit switch and an ON/OFF with built in circuit breaker. The coil is not factory wired to the unit controller.

Hot gas reheat (HGRH)

HGRH allows the unit to not only control space temperature, but also control humidity levels within the conditioned space. Both a thermostat and humidistat are needed for hot gas reheat operation. Once the thermostat reaches the set point temperature and if the humidity in the space is above set point, the factory-installed unit control board will energize the reheat valve allowing hot gas to flow from the

compressor to the hot gas reheat coil downstream of the air coil. The cool, moist air leaving the air coil is now reheated to produce warmer, dryer air. The call for sensible cooling will always take precedence over the call for dehumidification, so if at any point the space temperature rises above set point, the hot gas reheat is turned off allowing for cooling only.

The hot gas reheat coil and reheat valve are factory installed and factory wired to the unit controller. For hot gas reheat performance data consult the WSHP Builder selection software.

Typical unit control is by a wall-mounted thermostat that senses temperature in the occupied space. By utilizing a humidistat in addition to the thermostat, we are able to monitor the humidity levels in the space as well. The HGR option allows cooling and dehumidification to satisfy both the thermostat and humidistat while preventing over cooling of the space while in the dehumidification mode.

Hot gas bypass

Hot gas bypass prevents icing of the air coil when the unit is operating at low cooling load conditions. The hot gas bypass valve located in the compressor discharge line diverts hot gas to the inlet of the air coil. The valve is factory set to open when the evaporating pressure falls to 90 psig and will modulate to prevent the pressure falling any lower. This setting is field adjustable and this set point may be adjusted as required.

Water circuit options

These options provide internally mounted 3.0 gpm per ton automatic flow regulating valves for easier installation.

Two-way solenoid control valve

This two-way valve is optional on all unit sizes and is mounted internal to the unit. The valve opens to allow full fluid flow to the coaxial coil when there is a call for heating or cooling, and shuts when no call for heating or cooling exists.

Fan motor options

Constant torque ECMs are standard on sizes 015-070 and provide the efficiency and operability of an ECM at a lower cost than a constant airflow ECM. Constant torque ECMs provide 5 available motor speed taps and will maintain a constant motor torque as external static pressure in the system increases. As the system static pressure increases, reduction in fan airflow with a constant torque ECM is minor.

Constant airflow ECMs are optional on sizes 015-070 and will maintain constant unit airflow as the static pressure in the system increases. Constant airflow ECMs provide 3 available speed settings. 460V/3 Ph units with constant airflow ECM motors require a four wire configuration (L1, L2, L3, N).

Air coil protection

Optional tin electro-plated copper tubing with high-tech polymer coated aluminum fins will protect the evaporator coil from all forms of corrosive elements in the airstream.

Electric heater

Electric heat is a factory-installed option on vertical units with top discharge or horizontal units with end discharge. Electric heaters are available in 5, 10, 15, and 20 kW on units with either 208/230V-1Ph or 208/230V-3Ph power. Electric heaters shall be factory-wired and installed internal to the unit on the fan discharge.

Complete C and Deluxe D Package Capabilities

CAPABILITY	COMPLETE C PACKAGE	DELUXE D PACKAGE
High and Low Refrigerant Pressure Switches	X	X
Fluid Temperature (Freeze) Protection	X	X
Condensate Overflow Protection Sensor	X	X
Air Temperature (Freeze) Protection	X	X
Anti-Short Cycle Timer	X	X
Random Start Relay	X	X
Low Pressure Bypass Timer	X	X
Surge Protection	X	X
Intelligent Reset	X	X
Lockout Reset	X	X
Malfunction (Alarm) Output	X	X
Test Service Mode with LED Fault Indication	X	X
Dehumidification Control via Hot Gas Reheat	X	X
Electric Heater Control	X	X
Transformer	75 va	75 va
DDC Controls Compatible	X	X
Phase Monitor (3-Phase Units Only)		X
Boilerless Control		X
Energy Management Switch		X
Pump-Valve Relay		X

Deluxe D package provides all of the options on the standard Complete C package in addition to the following:

- Phase Monitor — Prevent motors from running at temperatures above approved ratings, and provides protection against phase loss, phase reversal, and phase unbalance.
- Boilerless Control — For use when the desired means of heating will be via an electric heater, and no boiler is installed in a water loop system.
- Energy Management Switch — Enables a 24 vac external signal to control the operation of the WSHP.
- Pump-Valve Relay — Provides a signal between an isolation valve and a secondary pump.

WSHP Open multi-protocol controller is an integrated component of a Carrier water source heat pump. The WSHP Open controller continuously monitors and regulates water source heat pump operation with reliability and precision. This advanced controller features a sophisticated, factory-engineered control program that provides optimum performance and energy efficiency.

The WSHP Open controller is factory installed and programmed to control all factory-installed standard options including hot gas reheat and waterside economizer as well as provide boilerless electric heat control and demand controlled ventilation.

The WSHP Open controller is programmed to communicate with different protocols including BACnet, N2, Modbus and LonWorks. While the controller is programmed to operate on Carrier's i-Vu® building automation system

(BAS), the WSHP Open controller can easily be integrated into a third party BAS.

NOTE: A separate LON integration card is required for LonWorks.

Three-speed fan control provides the most efficient WSHP operation. All WSHP Open controllers come programmed from the factory with 3-speed fan control, with user selectable low, medium and high fan speeds. Using the space temperature input, the WSHP Open controller will automatically operate the fan at the lowest of the 3 speeds to maintain space temperature while providing increased latent heat removal, reduced sound and the lowest fan energy consumption.

NOTE: Three-speed fan control is not available with constant airflow ECM fan motors. Three-speed fan control is available only with constant torque ECM and PSC fan motors.

Intuitive fault detection allows prolonged operation of the WSHP. The pre-programmed WSHP Open controller logic monitors and pre-emptively shuts down a WSHP as an alarming condition approaches instead of causing a hard lockout of the WSHP. This way, the WSHP can automatically restart if the fault condition clears within a set amount of time and a local reset of the WSHP is not required.

Learning adaptive optimal start transitions the WSHP from unoccupied set points to occupied set points in the most efficient means possible. Over time, the WSHP will learn and determine the best adjustment rates of the set points to provide the most efficient means of shifting the WSHP to an occupied mode.

Field-installed accessories

WSHP Open Equipment Touch™ and System Touch™ touchscreen devices have a color LCD display that allows easy connection to the controllers to view or change the controller's property values including set points, schedule equipment, view trends and alarms and more. The Equipment Touch device provides easy connection to one controller while the System Touch device can access up to 60 controllers when wired together as a network. For more details about the Equipment Touch and System Touch devices, see either the Equipment Touch or System Touch Installation and Setup Guide.

WSHP Open - ZS sensors

Carrier's ZS sensors are the preferred method of monitoring space temperature, humidity and CO₂ levels when using the WSHP Open controller.

NOTE: ZS sensor required for space temperature with all WSHP Open controllers. Only a ZS sensor can provide the necessary space temperature input for the WSHP Open controller.

Supply and return water hose kits are available as accessories. Hose kits are recommended for connection between the unit and the water loop piping. Hose kits are available in a variety of lengths, are flexible stainless steel, and have options for manual isolation valves with and without auto flow regulators and Y-strainers.

Electric duct heaters are available ranging from 5 to 20 kW of electric heat in all available WSHP voltages. These slip-in type heaters provide an extra means of auxiliary heat or reheat control.

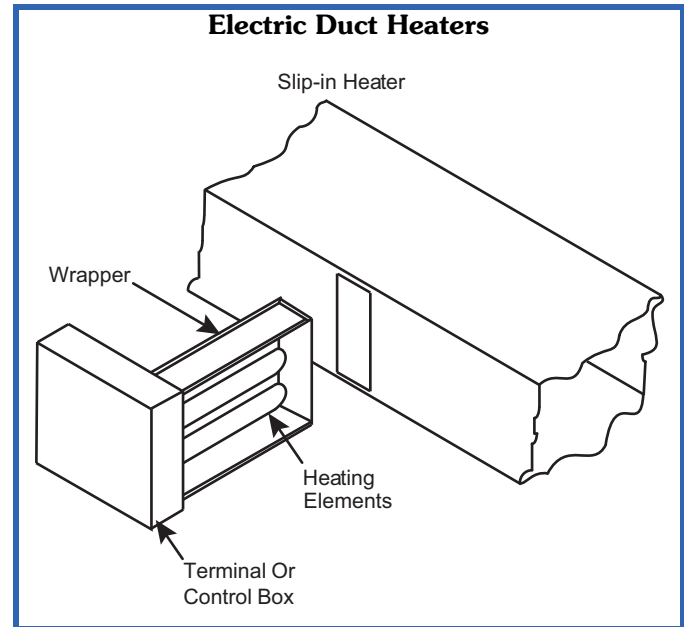

ZS Sensor Features

FEATURES	ZS STANDARD	ZS PLUS	ZS PRO	ZS PRO-F
Temp, CO ₂ , Humidity	X	X	X	X
Neutral Color	X	X	X	X
Addressable/Supports Daisy-Chaining	X	X	X	X
Hidden Communication Port	X	X	X	X
Mounts on a Standard 2-in. X 4-in. Electrical Box	X	X	X	X
Occupancy Status Indicator		X	X	X
Push-Button Occupancy Override		X	X	X
Set Point Adjust		X	X	X
Large, Easy-to-Read LCD			X	X
Alarm Indicator			X	X
Fan Speed Control				X
Cooling/Heating/Fan Only - Mode Control				X
F to C Conversion Button				X

ZS Sensor Options

OPTIONS	ZS STANDARD	ZS PLUS	ZS PRO	ZS PRO-F
	PART NUMBER			
Temperature Only	ZS-CAR	ZSPL-CAR	ZSP-CAR	ZSPF-CAR
Temperature with CO ₂	ZS-C-CAR	ZSPL-C-CAR	ZSP-C-CAR	ZSPF-C-CAR
Temperature with Humidity	ZS-H-CAR	ZSPL-H-CAR	ZSP-H-CAR	ZSPF-H-CAR
Temperature with Humidity and CO ₂	ZS-HC-CAR	ZSPL-HC-CAR	ZSP-HC-CAR	ZSPF-HC-CAR

Carrier Thermostat Options

THERMOSTAT TYPE	MODEL	DESCRIPTION
BACNET	Comfortvu BACnet Plus (TBPL-24-H-C / TBPL-24-HM-C)	1. 24 VAC controller with combination space temperature, relative humidity, and motion sensors (temperature, humidity only on TBPL-24-C).
	Comfortvu BACnet (TB-24-C / TB-24-HM-C)	2. Large touch screen backlit display, 7-day scheduling, demand response, remote sensor capability, dry contact.
WIFI	Connect BACnet Wi-Fi (33CONNECTSTAT43)	3. BACnet MS/TP, 1-3 stage heat, 1-2 stage cool, 1-3 fan speeds, WSE, HGRH, HP.
	Connect Wi-Fi (33CONNECTSTAT)	1. 24 VAC controller with on-board space temperature and relative humidity sensor.
PROGRAMMABLE/ NONPROGRAMMABLE	Edge Pro (33CS2PP2S-03 / 33CS2PPRH-03)	2. Large touch screen LCD display, 7-day scheduling, demand response, remote sensor capability.
	Comfort Pro (33CSCNACHP-01/ 33CSCPACHP-01)	3. BACnet MS/TP (33CONNECTSTAT43 only), up to 4 stage heat, up to 3 stage cool, WSE, HP.
PROGRAMMABLE/ NONPROGRAMMABLE	Edge Pro (33CS2PP2S-03 / 33CS2PPRH-03)	1. 24 VAC programmable control with on-board temperature and humidity (temperature only on 33CS2PP2S-03).
	Comfort Pro (33CSCNACHP-01/ 33CSCPACHP-01)	2. Backlit display 7-Day Programmable/Non-Programmable, 2-stage Heat/2-stage Cool, HP (with emergency heat).
PROGRAMMABLE/ NONPROGRAMMABLE	Edge Pro (33CS2PP2S-03 / 33CS2PPRH-03)	OR G/E, Dry Contact, Remote Sensor Capability, Pre-Occupancy Purge, Soft Start, Manual/Auto-Changeover, and Bypass Damper Output
	Comfort Pro (33CSCNACHP-01/ 33CSCPACHP-01)	1. 24 VAC Programmable/Non-Programmable (33CSCNACHP-01) control with on-board temperature.
PROGRAMMABLE/ NONPROGRAMMABLE	Edge Pro (33CS2PP2S-03 / 33CS2PPRH-03)	2. Backlit display, 2-stage Heat /2-stage Cool- G/E; plus 1-stage auxiliary or emergency heat HP and WSHP,
	Comfort Pro (33CSCNACHP-01/ 33CSCPACHP-01)	OR 2-stage cool/heat only, Passcode protection, remote sensor capability with override, random start, Manual/Auto-Changeover, Outdoor/supply/return temp, and hospitality.

See Carrier Thermostat Product Data for further details.

50PSH007-070 Units

UNIT	A	B	C	D	E	F	G	H	J	K	M	N	P	Q	FILTER RACK HEIGHT	R/A DUCT FLANGE HEIGHT	CONDENSER WATER CONNECTIONS	RECOMMENDED REPLACEMENT NOMINAL FILTER SIZE
	WIDTH	DEPTH*	HEIGHT	CAB END TO FILTER RACK	R/A DUCT WIDTH	CAB FRONT TO FILTER RACK	WATER IN	WATER OUT	SIDE TO DISC.	DISC. WIDTH	TOP TO DISC.	DISC. HEIGHT	END TO DISC.	TOP TO DISC.				
007	21.75	43.25	16.75	0.50	20.25	22.25	2.25	13.87	3.50	11.75	4.62	7.75	3.50	4.62	15.00	13.00	3/4 FPT	15 x 20 x 1
009	21.75	43.25	16.75	0.50	20.25	22.25	2.25	13.87	3.50	11.75	4.62	7.75	3.50	4.62	15.00	13.00	3/4 FPT	15 x 20 x 1
012	22.25	45.25	19.75	0.62	20.25	24.25	2.50	12.50	3.62	11.75	7.12	7.75	3.62	4.75	18.00	16.00	3/4 FPT	18 x 20 x 1
015	22.25	45.25	19.75	1.62	20.25	23.25	2.50	12.50	2.75	13.75	3.12	13.75	2.75	2.87	18.00	16.00	3/4 FPT	18 x 20 x 1
018	22.25	45.25	19.75	1.62	20.25	23.25	2.50	12.50	2.75	13.75	3.12	13.75	2.75	2.87	18.00	16.00	3/4 FPT	18 x 20 x 1
024	26.25	54.75	22.00	1.25	30.25	23.00	2.62	15.12	3.75	13.75	2.12	15.75	3.75	4.25	20.12	18.00	3/4 FPT	20 x 30 x 1
030	30.25	68.25	22.00†	2.00	35.00	31.25	2.50	13.25	4.50	15.75	4.00	15.75	4.50	2.25	20.12	18.00	1 FPT	20 x 34.5 x 1
036	30.25	68.25	22.00†	2.00	35.00	31.25	2.50	13.25	4.50	15.75	4.00	15.75	4.50	2.25	20.12	18.00	1 FPT	20 x 34.5 x 1
042	30.25	79.00	22.00†	0.75	48.25	29.62	2.75	13.25	4.50	17.75	2.25	17.75	4.50	2.12	20.12	18.00	1 FPT	20 x 24 x 1 (2)
048	30.25	79.00	22.00†	0.75	48.25	29.62	2.75	13.25	4.50	17.75	2.25	17.75	4.50	2.12	20.12	18.00	1 FPT	20 x 24 x 1 (2)
060	30.25	89.25	22.00†	1.87	56.25	31.00	2.62	13.25	4.50	17.75	2.25	17.75	4.50	2.12	20.12	18.00	1 FPT	20 x 28 x 1 (2)
070	30.25	89.25	22.00†	1.87	56.25	31.00	5.75	17.75	4.87	17.75	2.62	17.75	4.87	1.75	20.12	18.00	1 FPT	20 x 28 x 1 (2)

* When WSHP Open controller is installed increase depth by 2.6 inches.

† Total unit height is 22.75 with base rails for 030-070 units.

** Condensate drain connection is 3/4 in. FPT.

NOTES:

1. All dimensions in inches unless otherwise noted. All dimensions within ± 0.125 -in. Specifications subject to change without notice.
2. Unit sizes 015-070 discharge locations can be field converted between back discharge and side discharge.
3. Airflow configurations determined when facing panel with water connections.

Back Discharge

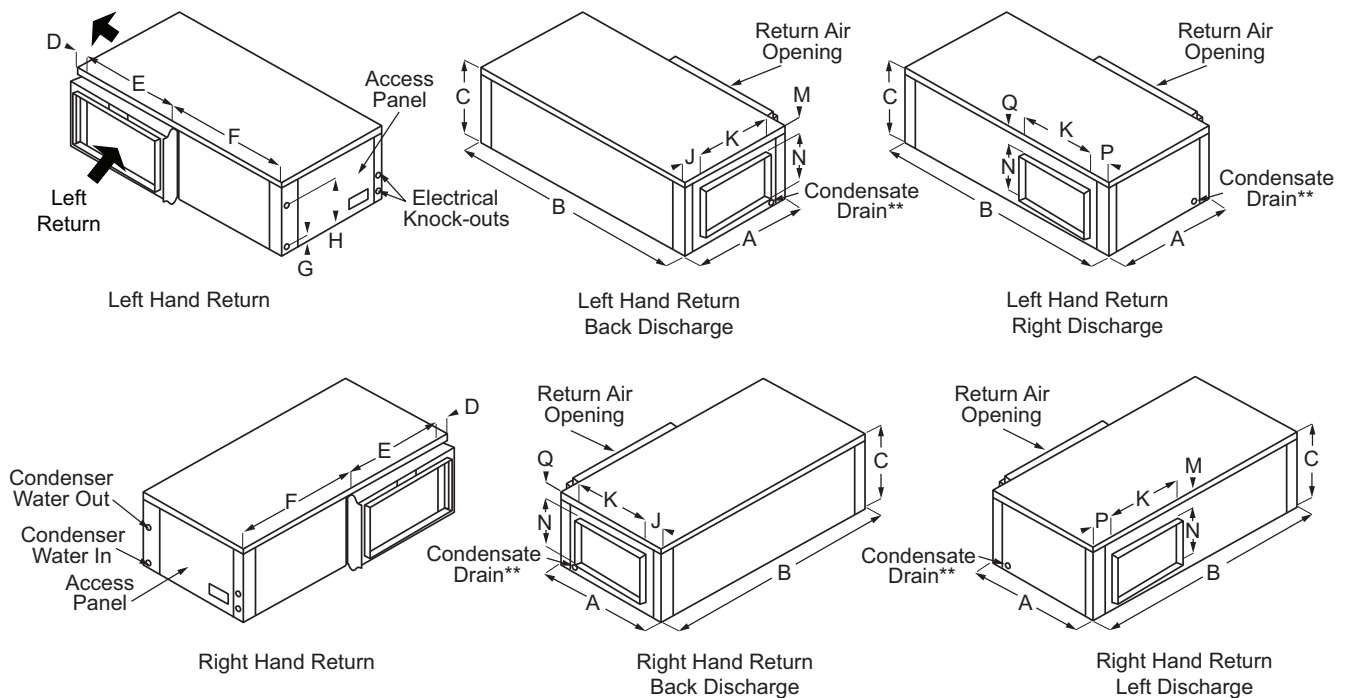

SERVICE CLEARANCES (TOP VIEW)

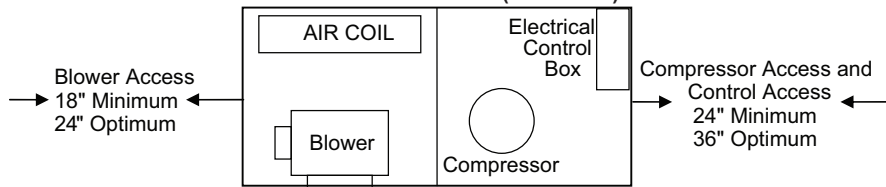

NOTE: The local electric codes may require 36-in. or more clearance at the electrical control box.

Dimensions (cont)



50PSV007-070 Units

UNIT	A	B	C	D	E	F	G	H	J	K	M	N	P	Q	CONDENSER WATER CONN.	RECOMMENDED REPLACEMENT FILTER SIZE
	WIDTH	DEPTH*	HEIGHT	DISCHARGE DEPTH	DISCHARGE WIDTH	CABINET EDGE TO DISCHARGE	LEFT SIDE TO DISC.	WATER IN	BOTTOM TO COND. DRAIN	WATER OUT	R/A DUCT WIDTH	R/A DUCT FLANGE HEIGHT	FILTER RACK HEIGHT	RIGHT SIDE TO DISC.		
007	21.75	21.75	32.75	11.75	7.75	5.00	8.50	2.25	8.00	13.75	18.00	13.00	15.00	5.32	3/4 FPT	15 x 20 x 1
009	21.75	21.75	32.75	11.75	7.75	5.00	8.50	2.25	8.00	13.75	18.00	13.00	15.00	5.32	3/4 FPT	15 x 20 x 1
012	21.75	21.75	32.75	11.75	7.75	5.00	8.50	2.62	7.50	12.50	18.00	16.00	18.00	5.32	3/4 FPT	18 x 20 x 1
015	21.75	21.75	39.25	13.75	13.75	4.00	6.12	2.25	7.50	12.25	18.00	18.00	20.00	4.00	3/4 FPT	20 x 20 x 1
018	21.75	21.75	39.25	13.75	13.75	4.00	6.12	2.25	7.50	12.25	18.00	18.00	20.00	4.00	3/4 FPT	20 x 20 x 1
024	21.75	26.25	47.25	13.75	15.75	6.25	4.87	2.50	8.75	15.00	22.00	22.00	24.00	4.00	3/4 FPT	24 x 24 x 1
030	24.25	33.50	47.25	15.75	15.75	8.87	7.00	2.50	8.50	14.50	28.00	22.00	24.00	4.00	1 FPT	24 x 30 x 1
036	24.25	33.50	47.25	15.75	15.75	8.87	7.00	2.50	8.50	14.50	28.00	22.00	24.00	4.00	1 FPT	24 x 30 x 1
042	26.25	33.50	58.25	17.75	17.75	7.87	6.75	3.25	8.50	13.25	28.00	30.00	32.00	4.00	1 FPT	16 x 30 x 1 (2)
048	26.25	33.50	58.25	17.75	17.75	7.87	6.75	3.25	8.50	13.25	28.00	30.00	32.00	4.00	1 FPT	16 x 30 x 1 (2)
060	26.25	33.50	66.25	17.75	17.75	7.87	7.00	3.25	8.50	13.25	28.00	38.00	40.00	4.00	1 FPT	20 x 30 x 1 (2)
070	26.25	33.50	66.25	17.75	17.75	7.87	7.25	4.25	10.00	17.00	28.00	38.00	40.00	3.00	1 FPT	20 x 30 x 1 (2)

* When WSHP Open controller is installed increase depth by 2.6 inches.

** Condensate drain connection is 3/4-in. FPT.

NOTES:

1. All dimensions in inches unless otherwise noted. All dimensions within ± 0.125 -in. Specifications subject to change without notice.
2. Airflow configuration determined when facing panel with water connections.

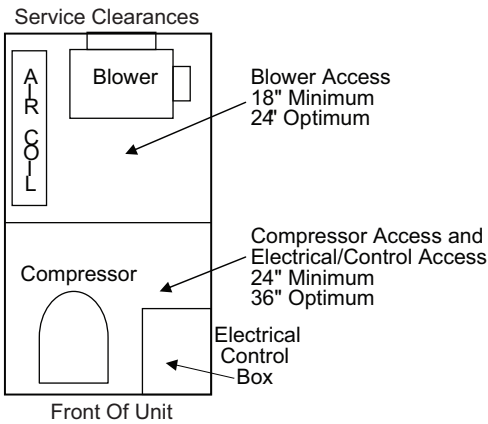
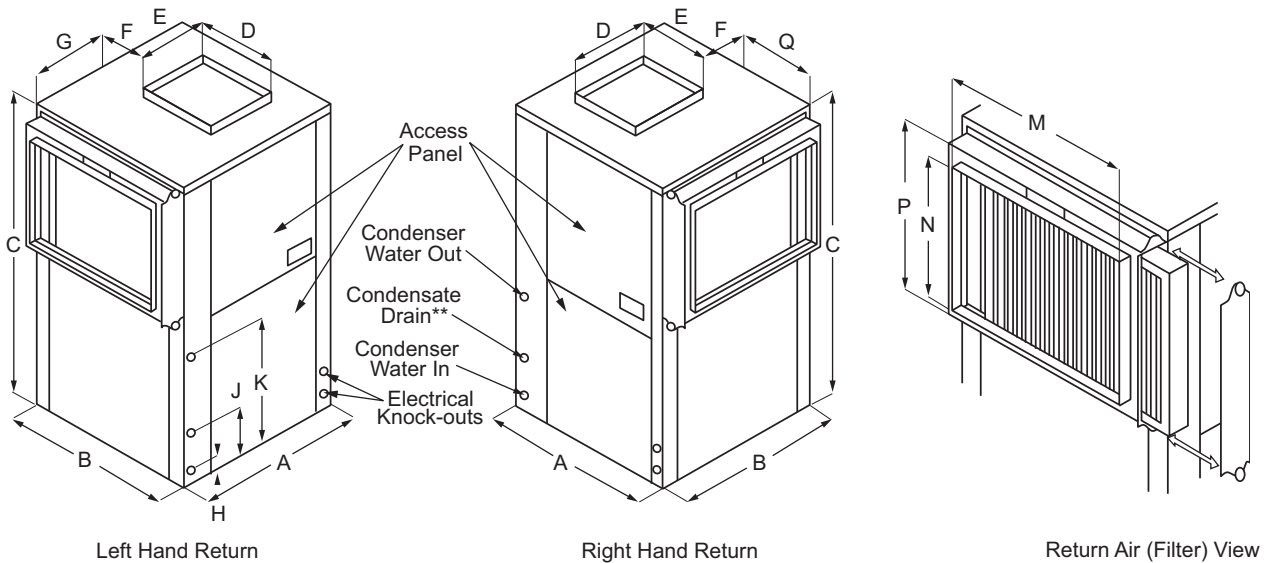

NOTE: The local electric codes may require 36-in. or more clearance at the electrical control box.

50PSH007-070 CORNER WEIGHTS

UNIT SIZE	TOTAL (lb)	LEFT HAND EVAPORATOR				RIGHT HAND EVAPORATOR			
		LEFT FRONT ^a (lb)	RIGHT FRONT ^a (lb)	LEFT BACK (lb)	RIGHT BACK (lb)	LEFT FRONT ^a (lb)	RIGHT FRONT ^a (lb)	LEFT BACK (lb)	RIGHT BACK (lb)
007	165	40	42	42	41	39	43	39	44
009	172	42	44	44	42	41	45	41	45
012	173	46	42	45	40	44	44	40	45
015	190	45	45	53	47	46	44	47	53
018	198	51	49	50	48	49	51	47	51
024	307	80	78	79	70	77	81	68	81
030	358	99	88	92	79	96	92	78	92
036	369	100	92	94	83	96	96	81	96
042	400	107	99	105	89	103	103	88	106
048	405	106	108	102	89	102	112	85	106
060	452	116	118	118	100	111	123	95	123
070	494	155	122	121	96	151	126	98	119

NOTE(S):

- a. Front is control box end.

Performance data



Please see the WSHP Builder for cooling, heating, and sound performance data.

Antifreeze Correction Table

ANTIFREEZE TYPE	ANTIFREEZE %	COOLING			HEATING		WPD CORRECTION FACTOR EWT 30°F
		EWT 90°F			EWT 30°F		
		Total Capacity	Sensible Capacity	kW	Heating Capacity	kW	
Water	0	1.000	1.000	1.000	1.000	1.000	1.000
Propylene Glycol	5	0.997	0.997	1.004	0.989	0.997	1.060
	10	0.994	0.994	1.006	0.986	0.995	1.125
	15	0.990	0.990	1.009	0.978	0.988	1.190
	25	0.983	0.983	1.016	0.960	0.979	1.300
	30	0.979	0.979	1.020	0.950	0.974	1.736
	35	0.975	0.974	1.024	0.940	0.969	1.834
Methanol	5	0.997	0.997	1.003	0.990	0.997	1.060
	10	0.996	0.996	1.005	0.979	0.993	1.100
	15	0.994	0.994	1.008	0.970	0.990	1.140
	20	0.992	0.992	1.011	0.961	0.987	1.248
Ethanol	5	0.998	0.998	1.002	0.981	0.994	1.160
	10	0.996	0.996	1.004	0.960	0.988	1.230
	15	0.992	0.992	1.006	0.944	0.983	1.280
	25	0.986	0.986	1.009	0.917	0.974	1.400
Ethylene Glycol	5	0.997	0.997	1.003	0.993	0.998	1.060
	10	0.995	0.995	1.004	0.986	0.996	1.120
	15	0.992	0.992	1.005	0.980	0.993	1.190
	25	0.988	0.988	1.009	0.970	0.990	1.330
	30	0.985	0.985	1.012	0.965	0.987	1.400

LEGEND

- EWT** — Entering Water Temperature
- WPD** — Water Pressure Differential

50PS Blower Performance Standard Motor - PSC for 007-012, Constant Torque ECM for 015-070

50PS	MOTOR SPEED	AIRFLOW (cfm) AT EXTERNAL STATIC PRESSURE (in. wg)											
		0.10	0.20	0.30	0.40	0.50	0.60	0.70	0.80	0.90	1.00	1.10	1.20
007	High	430	420	390	360	335	310	260	—	—	—	—	—
	Med	420	390	365	335	310	270	—	—	—	—	—	—
	Low ^a	370	360	340	315	285	245	—	—	—	—	—	—
009	High	430	420	390	360	335	310	260	—	—	—	—	—
	Med ^a	420	390	365	335	310	270	—	—	—	—	—	—
	Low	370	360	340	315	285	245	—	—	—	—	—	—
012	High ^a	450	435	415	400	385	360	330	305	—	—	—	—
	Med	425	405	385	375	360	335	310	—	—	—	—	—
	Low	390	380	365	350	335	315	290	—	—	—	—	—
015	High	710	685	650	610	575	545	460	370	—	—	—	—
	Med ^a	530	510	480	445	405	360	—	—	—	—	—	—
	Low	430	410	370	335	290	245	—	—	—	—	—	—
018	High	730	700	660	615	580	545	505	460	—	—	—	—
	Med ^a	615	575	540	500	460	420	—	—	—	—	—	—
	Low	540	510	480	445	405	360	—	—	—	—	—	—
024	High	975	945	910	880	855	825	790	750	—	—	—	—
	Med ^a	905	885	855	825	790	755	700	650	—	—	—	—
	Low	725	700	670	640	585	530	—	—	—	—	—	—
030	High	1,225	1,195	1,170	1,140	1,110	1,075	1,010	940	745	—	—	—
	Med ^a	1,110	1,075	1,045	1,015	985	955	915	880	700	—	—	—
	Low	955	925	890	860	825	790	750	715	685	—	—	—
036	High	1,440	1,420	1,400	1,380	1,345	1,315	1,240	1,165	1,005	845	—	—
	Med ^a	1,340	1,315	1,290	1,270	1,245	1,225	1,180	1,135	990	845	—	—
	Low	1,190	1,165	1,140	1,115	1,090	1,065	1,040	1,020	915	810	—	—
042	High	1,645	1,635	1,610	1,585	1,560	1,535	1,510	1,485	1,460	1,430	—	—
	Med ^a	1,455	1,425	1,400	1,375	1,345	1,320	1,290	1,260	1,225	1,190	—	—
	Low	1,220	1,190	1,160	1,130	1,100	1,070	1,015	955	895	830	—	—
048	High	1,840	1,820	1,795	1,775	1,745	1,720	1,695	1,670	1,645	1,615	—	—
	Med ^a	1,655	1,635	1,610	1,585	1,560	1,535	1,510	1,485	1,460	1,430	—	—
	Low	1,455	1,425	1,400	1,375	1,345	1,320	1,290	1,260	1,225	1,190	—	—
060	High	2,225	2,195	2,165	2,135	2,105	2,075	2,045	2,015	1,980	1,945	1,900	1,850
	Med ^a	2,070	2,045	2,015	1,990	1,960	1,925	1,895	1,870	1,840	1,810	1,685	1,600
	Low	1,815	1,785	1,755	1,725	1,695	1,665	1,630	1,595	1,555	1,515	1,425	—
070	High	2,560	2,520	2,480	2,440	2,400	2,360	2,320	2,275	2,245	2,210	2,150	2,050
	Med ^a	2,440	2,400	2,360	2,320	2,280	2,245	2,200	2,155	2,120	2,085	2,000	1,900
	Low	1,920	1,880	1,835	1,795	1,745	1,695	1,655	1,615	1,570	1,520	1,425	—

NOTE(S):

- a. Default factory setting.

50PS Blower Performance Constant Airflow ECM Motor

50PS	MOTOR SPEED	AIRFLOW (cfm) AT EXTERNAL STATIC PRESSURE (in. wg)												
		0.10	0.20	0.30	0.40	0.50	0.60	0.70	0.80	0.90	1.00	1.10	1.20	
015	+	575	575	575	575	575	575	575	575	575	—	—	—	—
	Normal ^a	500	500	500	500	500	500	500	500	500	—	—	—	—
	—	425	425	425	425	425	425	425	425	425	—	—	—	—
018	+	745	745	745	745	745	745	745	745	745	—	—	—	—
	Normal ^a	650	650	650	650	650	650	650	650	650	—	—	—	—
	—	555	555	555	555	555	555	555	555	555	—	—	—	—
024	+	1,095	1,095	1,095	1,095	1,095	1,095	1,095	1,095	1,095	1,095	—	—	—
	Normal ^a	950	950	950	950	950	950	950	950	950	950	—	—	—
	—	810	810	810	810	810	810	810	810	810	810	—	—	—
030	+	1,150	1,150	1,150	1,150	1,150	1,150	1,150	1,150	1,150	1,150	—	—	—
	Normal ^a	1,000	1,000	1,000	1,000	1,000	1,000	1,000	1,000	1,000	1,000	—	—	—
	—	850	850	850	850	850	850	850	850	850	850	—	—	—
036	+	1,380	1,380	1,380	1,380	1,380	1,380	1,380	1,380	1,380	1,380	1,380	—	—
	Normal ^a	1,200	1,200	1,200	1,200	1,200	1,200	1,200	1,200	1,200	1,200	1,200	—	—
	—	1,020	1,020	1,020	1,020	1,020	1,020	1,020	1,020	1,020	1,020	1,020	—	—
042	+	1,610	1,610	1,610	1,610	1,610	1,610	1,610	1,610	1,610	1,610	1,610	—	—
	Normal ^a	1,400	1,400	1,400	1,400	1,400	1,400	1,400	1,400	1,400	1,400	1,400	—	—
	—	1,190	1,190	1,190	1,190	1,190	1,190	1,190	1,190	1,190	1,190	1,190	—	—
048	+	1,840	1,840	1,840	1,840	1,840	1,840	1,840	1,840	1,840	1,840	1,840	—	—
	Normal ^a	1,600	1,600	1,600	1,600	1,600	1,600	1,600	1,600	1,600	1,600	1,600	—	—
	—	1,360	1,360	1,360	1,360	1,360	1,360	1,360	1,360	1,360	1,360	1,360	—	—
060	+	2,300	2,300	2,300	2,300	2,300	2,300	2,300	2,300	2,300	2,300	2,300	2,300	2,300
	Normal ^a	2,000	2,000	2,000	2,000	2,000	2,000	2,000	2,000	2,000	2,000	2,000	2,000	2,000
	—	1,700	1,700	1,700	1,700	1,700	1,700	1,700	1,700	1,700	1,700	1,700	1,700	—
070	+	2,415	2,415	2,415	2,415	2,415	2,415	2,415	2,415	2,415	2,415	2,415	2,415	2,415
	Normal ^a	2,100	2,100	2,100	2,100	2,100	2,100	2,100	2,100	2,100	2,100	2,100	2,100	2,100
	—	1,785	1,785	1,785	1,785	1,785	1,785	1,785	1,785	1,785	1,785	1,785	1,785	—

NOTE(S):

a. Default factory setting.

Standard Motor — PSC for 007-012, Constant Torque ECM for 015-070 Motor Electrical Data

50PS UNIT SIZE	RATED VOLTAGE v-ph-Hz	COMPRESSOR			BLOWER MOTOR			MIN. CIRCUIT AMP	MAX FUSE
		Qty	RLA	LRA	Qty	FLA	HP		
007	208/230-1-60	1	2.5	17.7	1	1.00	0.10	4.1	15
	265-1-60	1	2.6	13.5	1	1.00	0.10	4.3	15
009	208/230-1-60	1	3.4	22.2	1	1.00	0.10	5.3	15
	265-1-60	1	2.9	18.8	1	1.00	0.10	4.6	15
012	115-1-60	1	9.6	58.4	1	2.20	0.10	14.2	20
	208/230-1-60	1	4.6	27.9	1	1.00	0.10	6.8	15
	265-1-60	1	3.8	22.2	1	1.00	0.10	5.8	15
015	208/230-1-60	1	5.6	29.0	1	2.80	0.33	9.8	15
	265-1-60	1	4.6	20.0	1	2.60	0.33	8.4	15
018	208/230-1-60	1	7.4	33.0	1	2.80	0.33	12.1	15
	265-1-60	1	6.0	28.0	1	2.60	0.33	10.1	15
024	208/230-1-60	1	13.5	58.3	1	2.80	0.33	19.7	30
	265-1-60	1	9.0	54.0	1	2.60	0.33	13.9	20
	208/230-3-60	1	7.1	55.4	1	2.80	0.33	11.7	15
	460-3-60	1	3.5	28.0	1	2.10	0.50	6.5	15
030	208/230-1-60	1	12.8	58.3	1	4.10	0.50	20.1	30
	265-1-60	1	9.6	54.0	1	3.60	0.50	15.6	25
	208/230-3-60	1	7.7	55.4	1	2.80	0.50	13.7	20
	460-3-60	1	3.6	28.0	1	2.10	0.50	6.6	15
036	208/230-1-60	1	16.0	77.0	1	6.00	0.75	26.0	40
	208/230-3-60	1	10.0	71.0	1	6.00	0.75	18.5	25
	460-3-60	1	4.7	38.0	1	3.20	0.75	9.1	15
042	208/230-1-60	1	15.4	83.9	1	6.00	0.75	25.3	40
	208/230-3-60	1	10.4	73.0	1	6.00	0.75	19.0	25
	460-3-60	1	5.8	38.0	1	3.20	0.75	10.5	15
048	208/230-1-60	1	19.9	109.0	1	6.00	0.75	30.9	50
	208/230-3-60	1	13.6	83.1	1	6.00	0.75	23.0	35
	460-3-60	1	6.1	41.0	1	3.20	0.75	10.8	15
060	208/230-1-60	1	25.0	134.0	1	7.60	1.00	38.9	60
	208/230-3-60	1	15.9	110.0	1	7.60	1.00	27.5	40
	460-3-60	1	7.1	52.0	1	4.00	1.00	12.9	20
070	208/230-1-60	1	24.7	166.0	1	7.60	1.00	38.5	60
	208/230-3-60	1	15.6	110.0	1	7.60	1.00	27.1	40
	460-3-60	1	7.8	52.0	1	4.00	1.00	13.8	20

LEGEND

FLA — Full Load Amps
LRA — Locked Rotor Amps
RLA — Rated Load Amps



Constant Airflow ECM Motor Electrical Data

50PS UNIT SIZE	RATED VOLTAGE v-ph-Hz ^a	COMPRESSOR			BLOWER MOTOR			MIN. CIRCUIT AMP	MAX FUSE
		Qty	RLA	LRA	Qty	FLA	HP		
015	208/230-1-60	1	5.6	29.0	1	2.8	0.33	9.8	15
	265-1-60	1	4.6	20.0	1	2.6	0.33	8.4	15
018	208/230-1-60	1	7.4	33.0	1	2.8	0.33	12.1	15
	265-1-60	1	6.0	28.0	1	2.6	0.33	10.1	15
024	208/230-1-60	1	13.5	58.3	1	2.8	0.33	19.7	30
	265-1-60	1	9.0	54.0	1	2.6	0.33	13.9	20
	208/230-3-60	1	7.1	55.4	1	2.8	0.33	11.7	15
	460-3-60 ^b	1	3.5	28.0	1	2.6	0.33	7.0	15
030	208/230-1-60	1	12.8	58.3	1	2.8	0.33	18.8	30
	265-1-60	1	9.6	54.0	1	2.6	0.33	14.6	20
	208/230-3-60	1	7.7	55.4	1	2.8	0.33	12.4	20
	460-3-60 ^b	1	3.6	28.0	1	2.6	0.33	7.1	15
036	208/230-1-60	1	16.0	77.0	1	4.3	0.50	24.3	40
	208/230-3-60	1	10.0	71.0	1	4.3	0.50	16.8	25
	460-3-60 ^b	1	4.7	38.0	1	4.1	0.50	10.0	15
042	208/230-1-60	1	15.4	83.9	1	6.8	0.75	26.1	40
	208/230-3-60	1	10.4	73.0	1	6.8	0.75	19.8	30
	460-3-60 ^b	1	5.8	38.0	1	5.5	0.75	12.8	15
048	208/230-1-60	1	19.9	109.0	1	6.8	0.75	31.7	50
	208/230-3-60	1	13.6	83.1	1	6.8	0.75	23.8	35
	460-3-60 ^b	1	6.1	41.0	1	5.5	0.75	13.1	15
060	208/230-1-60	1	25.0	134.0	1	6.8	0.75	38.1	60
	208/230-3-60	1	15.9	110.0	1	6.8	0.75	26.7	40
	460-3-60 ^b	1	7.1	52.0	1	5.5	0.75	14.4	20
070	208/230-1-60	1	24.7	166.0	1	9.1	1.00	40.0	60
	208/230-3-60	1	15.6	110.0	1	9.1	1.00	28.6	40
	460-3-60 ^b	1	7.8	52.0	1	6.9	1.00	16.7	20

NOTE(S):

- a. 4-Wire design (L1, L2, L3, N) is required on 460V 3-Phase units with Constant Airflow ECM motor.
- b. 460-v unit contains 265-v fan motor and requires a neutral to power motor.

LEGEND

- FLA — Full Load Amps
- LRA — Locked Rotor Amps
- RLA — Rated Load Amps



First Data Plate for Units with EH Option - Compressor Power Connection

MODELS	RATED VOLTAGE	VOLTAGE MIN/MAX	COMPRESSOR			UNIT		
			QTY	RLA	LRA	FLA (AMPS)	MIN CIRCUIT AMPS	MAX FUSE/ HACR
50PS018	208-230/60/1	197/253	1	7.4	33.0	7.4	9.3	15
50PS024	208-230/60/1	197/253	1	13.5	58.3	13.5	16.9	30
	208-230/60/3	197/253	1	7.1	55.4	7.1	8.9	15
50PS030	208-230/60/1	197/253	1	12.8	58.3	12.8	16.0	25
	208-230/60/1	197/253	1	7.7	55.4	7.7	9.6	15
50PS036	208-230/60/1	197/253	1	16.0	77.0	16.0	20.0	35
	208-230/60/1	197/253	1	10.0	71.0	10.0	12.5	25
50PS042	208-230/60/1	197/253	1	15.4	83.9	15.4	19.3	35
	208-230/60/1	197/253	1	10.4	73.0	10.4	13.0	25
50PS048	208-230/60/1	197/253	1	19.9	109.0	19.9	24.9	40
	208-230/60/1	197/253	1	13.6	83.1	13.6	17.0	30
50PS060	208-230/60/1	197/253	1	25.0	134.0	25.0	31.3	55
	208-230/60/1	197/253	1	15.9	110.0	15.9	19.9	35
50PS070	208-230/60/1	197/253	1	24.7	166.0	24.7	30.9	55
	208-230/60/1	197/253	1	15.6	110.0	15.6	19.5	35

Second Data Plate for Units with Electric Heater Option and Constant Torque ECM Motor^{a,b}

UNIT SIZE	EH RATED kW	STAGE	HEATER WATTS		HEATER AMPS		MOTOR FLA (A)	CIRCUIT FUSES	MCA		MOP	
			240	208	240	208			240	208	240	208
018	4.8	1	4,800	3,600	20.0	17.3	2.8	—	28.5	25.1	30	30
024	4.8	1	4,800	3,600	20.0	17.3	2.8	—	28.5	25.1	30	30
	9.6	1	9,600	7,200	40.0	34.6	2.8	—	53.5	46.8	60	50
030	4.8	1	4,800	3,600	20.0	17.3	4.1	—	30.1	26.8	35	30
	9.6	1	9,600	7,200	40.0	34.6	4.1	—	55.1	48.4	60	50
036	4.8	1	4,800	3,600	20.0	17.3	6.0	—	32.5	29.1	35	30
	9.6	1	9,600	7,200	40.0	34.6	6.0	—	57.5	50.8	60	60
	14.4	2	14,400	10,800	60.0	51.9	6.0	F1/F2 F3/F4	82.5	72.4	90	80
042	4.8	1	4,800	3,600	20.0	17.3	6.0	—	32.5	29.1	35	30
	9.6	1	9,600	7,200	40.0	34.6	6.0	—	57.5	50.8	60	60
	14.4	2	14,400	10,800	60.0	51.9	6.0	F1/F2 F3/F4	82.5	72.4	90	80
048	4.8	1	4,800	3,600	20.0	17.3	6.0	—	32.5	29.1	35	30
	9.6	1	9,600	7,200	40.0	34.6	6.0	—	57.5	50.8	60	60
	14.4	2	14,400	10,800	60.0	51.9	6.0	F1/F2 F3/F4	82.5	72.4	90	80
	19.2	2	19,200	14,000	80.0	69.2	6.0	F1/F2 F3/F4	107.5	94.0	110	100
060	4.8	1	4,800	3,600	20.0	17.3	7.6	—	34.5	31.1	35	35
	9.6	1	9,600	7,200	40.0	34.6	7.6	—	59.5	52.8	60	60
	14.4	2	14,400	10,800	60.0	51.9	7.6	F1/F2 F3/F4	84.5	74.4	90	80
	19.2	2	19,200	14,000	80.0	69.2	7.6	F1/F2 F3/F4	109.5	96.0	110	100
070	4.8	1	4,800	3,600	20.0	17.3	7.6	—	34.5	31.1	35	35
	9.6	1	9,600	7,200	40.0	34.6	7.6	—	59.5	52.8	60	60
	14.4	2	14,400	10,800	60.0	51.9	7.6	F1/F2 F3/F4	84.5	74.4	90	80
	19.2	2	19,200	14,000	80.0	69.2	7.6	F1/F2 F3/F4	109.5	96.0	110	100

NOTE(S):

- a. Units with Factory Installed Electric Heat option will have two separate data plates for each electrical circuit.
- b. Electric heat is not available for horizontal-straight through airflow configuration.

LEGEND

- EH — Electric Heat
- FLA — Full Load Amps
- MCA — Minimum Circuit Amps
- MOP — Maximum Overcurrent Protection



Electrical data (cont)



Second Data Plate for Units with Electric Heater Option and Constant Airflow ECM Motor^{a,b,c}

UNIT SIZE	EH RATED kW	STAGE	HEATER WATTS		HEATER AMPS		MOTOR FLA (A)	CIRCUIT FUSES	MCA		MOP	
			240	208	240	208			240	208	240	208
018	4.8	1	4,800	3,600	20.0	17.3	2.8	—	28.5	25.1	30	30
024	4.8	1	4,800	3,600	20.0	17.3	2.8	—	28.5	25.1	30	30
	9.6	1	9,600	7,200	40.0	34.6	2.8	—	53.5	46.8	60	50
030	4.8	1	4,800	3,600	20.0	17.3	2.8	—	28.5	25.1	30	30
	9.6	1	9,600	7,200	40.0	34.6	2.8	—	53.5	46.8	60	50
036	4.8	1	4,800	3,600	20.0	17.3	4.3	—	30.4	27.0	35	30
	9.6	1	9,600	7,200	40.0	34.6	4.3	—	55.4	48.6	60	50
	14.4	2	14,000	10,800	60.0	51.9	4.3	F1/F2 F3/F4	80.4	70.3	90	80
042	4.8	1	4,800	3,600	20.0	17.3	6.8	—	33.5	30.1	35	35
	9.6	1	9,600	7,200	40.0	34.6	6.8	—	58.5	51.8	60	60
	14.4	2	14,400	10,800	60.0	51.9	6.8	F1/F2 F3/F4	83.5	73.4	90	80
048	4.8	1	4,800	3,600	20.0	17.3	6.8	—	33.5	30.1	35	35
	9.6	1	9,600	7,200	40.0	34.6	6.8	—	58.5	51.8	60	60
	14.4	2	14,400	10,800	60.0	51.9	6.8	F1/F2 F3/F4	83.5	73.4	90	80
	19.2	2	19,200	14,000	80.0	69.2	6.8	F1/F2 F3/F4	108.5	95.0	110	100
060	4.8	1	4,800	3,600	20.0	17.3	6.8	—	33.5	30.1	35	35
	9.6	1	9,600	7,200	40.0	34.6	6.8	—	58.5	51.8	60	60
	14.4	2	14,400	10,800	60.0	51.9	6.8	F1/F2 F3/F4	83.5	73.4	90	80
	19.2	2	19,200	14,000	80.0	69.2	6.8	F1/F2 F3/F4	108.5	95.0	110	100
070	4.8	1	4,800	3,600	20.0	17.3	9.1	—	36.4	33.0	35	35
	9.6	1	9,600	7,200	40.0	34.6	9.1	—	61.4	54.6	70	60
	14.4	2	14,400	10,800	60.0	51.9	9.1	F1/F2 F3/F4	86.4	76.3	90	80
	19.2	2	19,200	14,000	80.0	69.2	9.1	F1/F2 F3/F4	111.4	97.9	120	100

NOTE(S):

- a. Units with Factory Installed Electric Heat option will have two separate data plates for each electrical circuit.
- b. Electric heat is not available for horizontal-straight through airflow configuration.
- c. 4-wire design (L1, L2, L3, N) is required on 460V 3-Phase units with Constant Airflow ECM motor.

LEGEND

- EH** — Electric Heat
- FLA** — Full Load Amps
- MCA** — Minimum Circuit Amps
- MOP** — Maximum Overcurrent Protection



Aquazone™ water source heat pump products are available in a flexible, efficient array of models, which can be used in all types of water loop, ground water, and ground loop systems. Utilize Aquazone products to provide optimal energy efficient solutions and adapt to the most challenging design requirements.

Aquazone Product Guide

50 SERIES	TYPE SIZE (tons)	APPLICATION
50HQP, VQP	Large Capacity 6-20 (HQP) 6-30 (VQP)	Environmentally sound unit with Puron® refrigerant (R-410A) designed to handle large zoned areas for all geothermal and boiler/tower applications.
50PC	Compact 1/2-6	Compact WSHP with Puron refrigerant (R-410A) for boiler/tower, ground water, or ground loop systems.
50PS	Premium Efficiency 1/2-6	Premium, ultra efficient unit with Puron refrigerant (R-410A) for new boiler/tower, ground water, or ground loop systems.
50PEC	High Efficiency Console 3/4-1-1/2	Efficient console unit with Puron refrigerant (R-410A) and attractive design for finished interior, under-window installations.
50PT	Premium Efficiency 2-Stage 2-6	Premium, ultra efficient 2-stage unit with Puron refrigerant (R-410A) for new boiler/tower, ground water, or ground loop systems.
50PSW	Water-to-Water 3-35	Efficient unit with Puron refrigerant (R-410A) serves as an alternative to pre-heat or cool air. Unit can be used as a stand-alone or supplemental boiler/chiller in most hydronic heating applications. Also conditions process fluids, lubricants, and refrigerants.

Water loop system

Water loop (or boiler/tower) system applications typically include a number of units plumbed to a common piping system. For optimal performance, this system should be designed between 2.25 and 3 gpm per ton of cooling capacity. The system is comprised of highly efficient packaged reverse cycle heat pump units interconnected by a water loop. The water circuit serves as both a sink and source for heat absorption and rejection and is designed for entering water temperatures between 50°F and 90°F. Within this temperature range units can heat or cool as required from the same water source. Transferring heat from warm to cold spaces in the building, whenever they coexist, conserves energy rather than creating new heat.

Refer to the **Carrier Water Source Heat Pump System Design Guide** for assistance with the design of water loop systems. The guide includes a practical approach for the latest and most current design recommendations including:

- product application, including horizontal, vertical, console, rooftop and water-to-water applications
- ventilation methods and system design, including energy recovery
- acoustical considerations for different product types
- addressing indoor air quality (IAQ) issues such as condensate removal and humidity control
- air distribution design including diffuser selection/ layout and ductwork design
- hydronic system design including pipe sizing/layout and boiler/tower sizing

- control configurations such as standalone, DDC, DCV, and VVT® controls
- Water Source Heat Pump Efficiency/Operational Cost Comparison chart
- system variations such as a system without a boiler, variable pumping, and variable air volume (VAV) for interior use

Ground water systems

To utilize Aquazone units in ground water applications, extended range should be specified. This will provide factory-installed insulation on the coaxial coil to prevent condensate from dripping when entering water temperatures are below 50°F. In addition, the copper coaxial coil installed on the Aquazone units may not be suitable for all water conditions. Refer to the Water Conditioning section for proper coaxial coil material selection.

Surface water system

This system is typically located near a lake or pond. In this application, the loop can be submerged in a series of coils beneath the water surface. The number of coils required depends on system load and design. This application requires minimum piping and excavation.

Open loop system

This system is used where ground water is plentiful. In this application, ground water is pumped through supply piping from the well to the building. The water is then pumped back into the ground through a discharge well as it leaves the building. An additional heat exchanger is usually installed between the building water piping system and the ground water piping system. This design limits the amount of piping and excavation required.

Aquazone units are provided with a standard thermostatic expansion valve (TXV) and are rated to extremely low temperatures to self-adjust the refrigeration circuit. To conserve water on this type of system, a slow opening/closing solenoid valve is recommended. Depending on loop water temperatures, a water regulating valve may be needed.

Ground loop systems

There are many commonly specified designs for ground loop applications. Typical designs include vertical and horizontal loops. In some applications, water is piped from the ground or lake directly to the water source heat pump. Piping is limited to the amount of pipe required to get the water from the source to the unit.

NOTE: When utilizing Aquazone water source heat pumps in ground loop systems, refer to design considerations in the ground water system section.

Horizontal ground loop

This system is used when adequate space is available and trenching can be easily accomplished. A series of parallel pipes are laid out in trenches 3 to 6 ft below the ground surface, and then back-filled. Often, multiple pipes are used to maximize the heat transfer capability of each trench. The amount of pipe and the size of the ground loop field are based on ground conditions, heating, and cooling requirements of the application and system design.

Vertical ground loop

This system is used in vertical borehole applications. This design is well suited for retrofit applications when space is limited or where landscaping is already complete and minimum disruption of the site is desired. The vertical ground loop system contains a single loop of pipe inserted into a hole. The hole is back-filled and grouted after the pipe is inserted. The completed loop is concealed below ground. The number of loops required depends on ground conditions, heating and cooling requirements, and the depth of each hole.

Hybrid systems

In some applications, it may be beneficial to incorporate a cooling tower into the ground loop system to reduce the overall cost. A hybrid system discards excess heat into the air and increases the cooling performance of the ground loop.

Condensate drainage

Venting

Condensate lines should be properly vented to prevent fan pressure from causing water to hang up in the piping. Condensate lines should be pitched to assure full drainage of condensate under all load conditions. Chemical treatment should be provided to remove algae in the condensate pans and drains in geographical areas that are conducive to algae growth.

Trapping

Condensate trapping is essential on every water source heat pump unit. A trap is provided to prevent the backflow of moisture from the condensate pan and into the fan intake or downstream into the mechanical system. The water seal or the length of the trap depends on the positive or negative pressure on the drain pan. As a rule of thumb, the water seal should be sized for 1 in. for every 1 in. of negative pressure on the unit. The water seal is the distance from the bottom of the unit condensate piping connection to the bottom of the condensate drain line run-out piping. Therefore, the trap size should be double the water seal dimension.

Horizontal units

Horizontal units should be sloped toward the drain at a 1/4 in. per foot pitch. If it is not possible to meet the pitch

requirement, a condensate pump should be designed and installed at the unit to pump condensate to a building drain. Horizontal units are not internally trapped; therefore an external trap is necessary. Each unit must be installed with its own individual trap and means to flush or blow out the condensate drain. The design of a common trap or vent for multiple units is not acceptable. The condensate piping system should not be designed with a pipe size smaller than the drain connection pipe size.

Vertical units

All vertical units require installation of an external trap.

Water conditioning

In some applications, maintaining proper water quality may require the use of higher corrosion protection for the water-to-refrigerant heat exchanger. Water quality varies from location to location and is unique for each job. Water characteristics such as pH value, alkalinity, hardness, and specific conductance are of importance when considering any WSHP application. Water typically includes impurities and hardness that must be removed. The required treatment will depend on the water quality as well as type of system. Water problems fall into three main categories:

1. Scale formation caused by hard water reduces the heat transfer rate and increases the water pressure drop through the heat exchanger. As water is heated, minerals and salts are precipitated from a solution and deposited on the inside surface of the pipe or tube.
2. Corrosion is caused by absorption of gases from the air coupled with water on exposed metal. Corrosion is also common in salt-water areas.
3. Organic growths such as algae can reduce the heat transfer rate by forming an insulating coating on the inside tube surface. Algae can also promote corrosion by pitting.

NOTE: In most commercial water loop applications, Aquazone™ WSHP units use a copper water-to-refrigerant heat exchanger. Units can and should be equipped with a cupronickel heat exchanger for applications where water is outside the standard contaminant limits for a copper heat exchanger.

Water Quality Guidelines

CONDITION	HX MATERIAL ^a	CLOSED RECIRCULATING ^b	OPEN LOOP AND RECIRCULATING WELL ^c		
Scaling Potential — Primary Measurement					
Above the given limits, scaling is likely to occur. Scaling indexes should be calculated using the limits below.					
pH/Calcium Hardness Method	All	N/A	pH < 7.5 and Ca Hardness, <100 ppm		
Index Limits for Probable Scaling Situations (Operation outside these limits is not recommended.)					
Scaling indexes should be calculated at 150°F for direct use and HWG applications, and at 90°F for indirect HX use. A monitoring plan should be implemented.					
Ryznar Stability Index	All	N/A	6.0 - 7.5 If >7.5 minimize steel pipe use.		
Langelier Saturation Index	All	N/A	-0.5 to +0.5 If <-0.5 minimize steel pipe use. Based upon 150°F HWG and direct well, 85°F indirect well HX.		
Iron Fouling					
Iron Fe²⁺ (Ferrous) (Bacterial Iron Potential)	All	N/A	<0.2 ppm (Ferrous) If Fe ²⁺ (ferrous) >0.2 ppm with pH 6 - 8, O ₂ <5 ppm check for iron bacteria.		
Iron Fouling	All	N/A	<0.5 ppm of Oxygen Above this level deposition will occur.		
Corrosion Prevention^d					
pH	All	6 - 8.5 Monitor/treat as needed.	6 - 8.5 Minimize steel pipe below 7 and no open tanks with pH <8.		
Hydrogen Sulfide (H₂S)	All	N/A	<0.5 ppm At H ₂ S>0.2 ppm, avoid use of copper and cupronickel piping or HXs. Rotten egg smell appears at 0.5 ppm level. Copper alloy (bronze or brass) cast components are okay to <0.5 ppm.		
Ammonia Ion as Hydroxide, Chloride, Nitrate and Sulfate Compounds	All	N/A	<0.5 ppm		
Maximum Chloride Levels			Maximum allowable at maximum water temperature.		
			50°F (10°C)	75°F (24°C)	100°F (38°C)
	Copper	N/A	<20 ppm	NR	NR
	Cupronickel	N/A	<150 ppm	NR	NR
	304 SS	N/A	<400 ppm	<250 ppm	<150 ppm
	316 SS	N/A	<1000 ppm	<550 ppm	<375 ppm
	Titanium	N/A	>1000 ppm	>550 ppm	>375 ppm
Erosion and Clogging					
Particulate Size and Erosion	All	<10 ppm of particles and a maximum velocity of 6 fps. Filtered for maximum 800 micron size.	<10 ppm (<1 ppm "sandfree" for reinjection) of particles and a maximum velocity of 6 fps. Filtered for maximum 800 micron size. Any particulate that is not removed can potentially clog components.		
Brackish	All	N/A	Use cupronickel heat exchanger when concentrations of calcium or sodium chloride are greater than 125 ppm are present. (Seawater is approximately 25,000 ppm.)		

NOTE(S):

- a. Heat exchanger materials considered are copper, cupronickel, 304 SS (stainless steel), 316 SS, titanium.
- b. Closed recirculating system is identified by a closed pressurized piping system.
- c. Recirculating open wells should observe the open recirculating design considerations.
- d. If the concentration of these corrosives exceeds the maximum allowable level, then the potential for serious corrosion problems exists. Sulfides in the water quickly oxidize when exposed to air, requiring that no agitation occur as the sample is taken. Unless tested immediately at the site, the sample will require stabilization with a few drops of one Molar zinc acetate solution, allowing accurate sulfide determination up to 24 hours after sampling. A low pH and high alkalinity can cause system problems, even when both values are within ranges shown. The term pH refers to the acidity, basicity, or neutrality of the water supply. Below 7.0, the water is considered to be acidic. Above 7.0, water is considered to be basic. Neutral water registers a pH of 7.0. To convert ppm to grains per gallon, divide by 17. Hardness in mg/l is equivalent to ppm.

LEGEND

- HWG** — Hot Water Generator
- HX** — Heat Exchanger
- N/A** — Design Limits Not Applicable Considering Recirculating Potable Water
- NR** — Application Not Recommended
- SS** — Stainless Steel

Acoustical design

Sound power levels represent the sound as it is produced by the source, the WSHP unit, with no regard to attenuation between the source and the space. Acoustical design goals are necessary to provide criteria for occupied spaces where people can be comfortable and communicate effectively over the background noise of the air-conditioning system and other background noise sources.

Acoustical design goals are desirable sound pressure levels within a given conditioned space and are represented by noise criteria (NC) curves. The NC curve levels represent a peak over a full spectrum of frequencies. A high value in a low frequency band has the same effect on NC level as a lower value in a high frequency band. It is important that sound levels be balanced over the entire spectrum relative to the NC curve. The lower the NC criteria curve, the more stringent the room acoustical design must be to meet the design goals.

It is important to know how to convert NC levels from the unit ratings in terms of sound power (L_w). This conversion depends on the specifics of the acoustical environment of the installation.

The resulting calculations are compared to the NC curve selected for the area to assess the acoustical design.

Some of the factors that affect conversion of sound power to sound pressure and consequent NC level include:

- type of acoustical ceiling
- use of metal or flex duct
- absorption in the occupied space
- location in the occupied space
- open or closed layout plan
- use of open or ducted returns
- orientation of unit to occupant
- use of lined or unlined duct

WSHP sound control

The analysis of the projected sound level in the conditioned space caused by a WSHP unit located in a ceiling plenum is quite involved. The key is to have good sound power ratings (L_w) in dB on the equipment to determine the sound attenuation effect of the ductwork, ceiling and room. In combination with utilizing standard Aquazone™ equipment attenuating features or the advanced mute package features, suggestions for horizontal and vertical unit sound design are provided to design around the WSHP units.

Horizontal units

Use the following guidelines for layout of Aquazone horizontal units to minimize noise:

1. Obtain sound power ratings in accordance with latest standards from manufacturers to select quietest equipment.
2. Do not locate units over a space with a required NC of 40 or less. Instead, locate units above less sensitive noise areas such as above or in equipment rooms, utility closets, restrooms, storage rooms, or above corridors.
3. Provide at least 10 feet between WSHP units to avoid the additive effect of two noise sources.
4. Provide an acoustical pad underneath the WSHP unit in applications where the unit must be mounted above noise sensitive areas such as private offices or confer-

ence rooms. The pad attenuates radiated noise. Be sure the pad has an area at least twice that of the WSHP footprint.

5. Maximize the installed height above the suspended ceiling.
6. Be sure the WSHP unit is located at least 6 feet away from any ceiling return grille to prevent line-of-sight casing noise from reaching the space below.
7. Suspend the WSHP unit from the ceiling with hangers that utilize spring or neoprene type isolators to reduce vibration transmission.
8. Utilize flexible electrical connections to the WSHP unit. **DO NOT USE RIGID CONNECTIONS.**
9. Utilize flexible loop water and condensate piping connections to the WSHP unit.
10. Use a canvas duct connector to connect the WSHP discharge to the downstream duct system. This reduces vibration-induced noise.
11. Provide acoustic interior lining for the first 20 feet of discharge duct, or until the first elbow is reached. The elbow prevents line-of-site sound transmission in the discharge duct.
12. Provide turning vanes in ductwork elbows and tees to reduce air turbulence.
13. Size the sheet metal supply duct with velocities no greater than 1000 fpm.
14. Ensure ductwork is rigid.
15. Use round duct whenever possible to further reduce noise.
16. Allow at least 3 equivalent duct diameters of straight duct upstream and downstream of the unit before allowing any fittings, transitions, etc.
17. Seal all penetrations around duct entering the space.
18. Provide a 4-ft run-out duct made of flexible material to connect a diffuser to the supply trunk duct. The flex duct provides an “attenuating end-effect” and reduces duct-transmitted sound before it reaches the space. Typically a 6 dB sound reduction can be accomplished with the use of flex duct.
19. Locate the run-out duct balancing damper as far away from the outlet diffuser as possible. Locating the balancing damper at the trunk duct exit is the best location.
20. If return air is drawn through a ceiling plenum, provide an acoustically lined return duct elbow or “L” shaped boot at the WSHP to eliminate line-of-sight noise into the ceiling cavity and possibly through ceiling return air grilles. Face the elbow or boot away from the nearest adjacent WSHP unit to prevent additive noise.
21. Do not hang suspended ceiling from the ductwork.

Vertical units

All guidelines established for horizontal units also apply for vertical units. In addition, since vertical units tend to be installed in small equipment rooms or closets, the following guidelines apply:

1. Mount the unit on a pad made of high-density sound absorbing material such as rubber or cork. Extend the pad beyond the WSHP unit footprint by at least 6 inches in each direction.
2. Since the unit returns airflow through a grille mounted in a closet door, provide a sound barrier or some other

modification of the closet to prevent line-of-sight noise into the space.

3. Follow good duct design practice in sizing and locating the connection of the WSHP discharge to the supply duct system. Use an elbow with turning vanes and bent in the direction of the fan rotation to minimize turbulence. Make any duct transitions as smooth and as gradual as possible to again minimize turbulence and loss of fan static pressure.

Solenoid valves

In applications using variable flow pumping, solenoid valves can be field-installed and operated from the control board in the Aquazone™ WSHP unit.

Freeze protection

Applications where systems are exposed to outdoor temperatures below freezing (32°F) must be protected from freezing. The most common method of protecting water systems from freezing is adding glycol concentrations into the water. Design care should be used when selecting both the type and concentrations of glycol utilized due to the following:

- Equipment and performance may suffer with high concentrations of glycol and other antifreeze solutions.
- Loss of piping pressure may increase greatly, resulting in higher pumping costs.
- Higher viscosity of the mixture may cause excess corrosion and wear on the entire system.
- Acidity of the water may be greatly increased, promoting corrosion.
- Glycol promotes galvanic corrosion in systems of dissimilar metals. The result is corrosion of one metal by the other, causing leaks.

Hot gas reheat

Hot gas reheat (HGRH) allows the user to not only control space temperature, but also humidity levels within the conditioned space. Excessive moisture in the space can promote mold growth leading to damage in the structure or interior surfaces, as well as reducing the air quality and creating an unhealthy environment.

Possible causes of excess humidity could be a byproduct of the unit having to operate under a widely varying load, an

oversized short cycling unit, a high percentage of unconditioned outside air being introduced into the space, a high latent load in the space or any location where humidity infiltration is a problem.

Typical unit control is by a wall mounted thermostat that senses temperature in the occupied space. By utilizing a humidistat in addition to the thermostat, part load units with hot gas reheat are able to control the humidity levels in the space well. The hot gas reheat option allows cooling and dehumidification to satisfy both the thermostat and humidistat while preventing over-cooling of the space while in the dehumidification mode.

Once the thermostat reaches set point temperature, and is above humidity set point, the unit controller will energize the reheat valve operating the unit in hot gas reheat mode, first cooling and dehumidifying, then reheating the air (using hot refrigerant gas) before delivering it to the space, usually 2 to 5°F below room temperature. The unit operates like a dehumidifier by reheating the air along a constant sensible heat line, while the relative humidity of the leaving air is reduced. This option offers significant energy savings over reheating air with electric heating coils.

The moisture removal capacity of a specific heat pump is determined by the unit latent capacity rating. A heat pump's latent capacity can be determined by reviewing the heat pump specification data sheets. Depending upon the entering water and air conditions, a total and sensible capacity can be interpolated from the data sheets. Subtracting sensible capacity from total capacity yields latent capacity. Dividing the latent capacity by 1069 converts the amount of moisture removal from Btuh to lb/hr.

A hot gas reheat valve and a reheat coil are optimal and included in the refrigerant circuit. The refrigerant circuits in the cooling and heating modes are identical to a standard heat pump. In the reheat mode, the compressor discharge gas is diverted through the reheat valve to the reheat coil which is located downstream of the cooling coil. The superheated refrigerant gas reheats the air leaving the cooling coil. The hot refrigerant gas then passes through the water to refrigerant coil where it is condensed to a liquid. From this point the rest of the cooling cycle is completed as in a regular heat pump. There are check valves to prevent refrigerant flow into the reheat coil during standard cooling/heating cycles.

The WSHP Open multi-protocol controller will control mechanical cooling, heating, hot gas reheat and waterside economizer outputs based on its own space temperature input and set points. An optional CO₂ IAQ (indoor air quality) sensor mounted in the space can maximize the occupant comfort. The WSHP Open controller has its own hardware clock that is automatically set when the heat pump software is downloaded to the board. Occupancy types are described in the scheduling section below. The following sections describe the functionality of the WSHP Open multi-protocol controller. All point objects that are referred to in this sequence of operation will be referenced to the objects as viewed in the BACview⁶ handheld user interface.

Scheduling

Scheduling is used to start and stop the unit based upon a time period to control the space temperature to specified occupied heating and cooling set points. The controller is defaulted to control by occupied set points all the time, until either a Time Schedule is configured with the Equipment Touch™ interface, i-Vu Open, or a third party control system Enables/Disables the BAS On/Off point. Your local time and date must be set for these functions to operate properly. The occupancy source can be changed to one of the following:

Occupancy schedules

The controller will be occupied 24/7 until a Time schedule has been configured using either, i-Vu Open, Equipment Touch or a third party Enables/Disables the BAS On/Off point. This can be disabled by going to Config>Unit>Occupancy Schedules and changing the point from Enable to Disable.

NOTE: This point must be Enabled in order for i-Vu Open or Bacview⁶ to assign a Time schedule to the controller.

Schedule

The unit will operate according to the schedule configured and stored in the unit. The schedule is accessible via the Equipment Touch user interface, i-Vu Open, or Field Assistant. The daily schedule consists of a start/stop time (standard or 24 hour mode) and seven days of the week, starting with Monday and ending on Sunday.

Occupancy input contact (option)

If configured for remote occupancy control (default), the WSHP Open controller has the capability to use an external dry contact closure to determine the occupancy status of the unit. You will need to disable the Occupancy Schedules in order to utilize the Occupancy Contact Input. The control will cause the unit to go into an occupied mode whenever the abnormal input is sensed. After the input returns to its normal state, the unit will stay in the occupied mode for the configured Occupancy Override Delay period (15 minutes default).

NOTE: Scheduling can only be controlled from one source.

BAS (building automation system) on/off

For use with a Building Automation System that supports network scheduling, you will need to disable the Occupancy Schedules so the BAS system can control the unit through a network communication and the BAS scheduling function.

NOTE: Scheduling can only be controlled from one source.

Global occupancy scheduling

The WSHP Open controller has the capability to read the occupancy status from another unit so that a group of WSHPs can be controlled from a single occupancy schedule. The local occupancy schedules must be disabled in order to utilize the global occupancy input.

NOTE: Scheduling can only be controlled from one source.

BACnet network occupancy input

The WSHP Open controller has the capability to accept an external BACnet Binary Network Input for occupancy control. This function is only compatible with units used in BACnet systems. You will need to configure the “System Occupancy” BACnet network input point to locate the device and point name where the external occupancy point information resides. Also occupancy schedules must be disabled in order to utilize this input.

NOTE: Scheduling can only be controlled from one source.

Fire/smoke detector (FSD) input (field optional)

The WSHP Open controller has the capability to read the status of a NC FSD contact input to determine if a fire or smoke detector alarm is present. If the controller determines an alarm condition is present, all heating, cooling and the fan are disabled. The normal state of the switch is factory set to Normally Closed and cannot be changed.

NOTE: ECM fans have a programmed delay and will not shut down immediately.

Shutdown input

The WSHP Open controller has a shutdown input (software) which when set to its Active mode will cause the WSHP to safely shut down in a controlled fashion. Heating and cooling will be disabled after any minimum runtime conditions expire and the fan will be disabled after the fan off timer expires. All alarms are reset but any active alarm will remain active. After the shutdown input transitions from Active mode to Inactive mode, the WSHP Open controller will restart after the configured power fail restart delay expires.

Indoor fan

The indoor fan will operate in any one of three modes depending upon the user configuration selected. Fan mode can be defined/selected as Auto, Continuous, or Always On. In Auto mode the fan is in intermittent operation during both occupied and unoccupied periods. Continuous fan is intermittent during unoccupied periods and continuous during occupied periods. Always On operates the fan continuously during both occupied and unoccupied periods. In the default mode, Continuous, the fan will be turned on whenever any one of the following is true:

- It is in occupied mode. Determined by its occupancy status.
- Whenever there is a demand for cooling or heating in the unoccupied mode.
- When there is a call for dehumidification (optional).

When power is reapplied after a power outage, there will be a configured time delay of 5 to 600 seconds before starting the fan. There are also configured fan delays for Fan On and Fan Off. The fan on delay defines the delay time (0 to 30 seconds; default 10) before the fan begins to operate after heating or cooling is started while the fan off delay defines the delay time

(0 to 180 seconds; default 45) the fan will continue to operate after heating or cooling is stopped. The fan will continue to run as long as the compressors, heating stages, or the dehumidification relays are on. If the SPT failure alarm or condensate overflow alarm is active; the fan will be shut down immediately regardless of occupancy state or demand.

Automatic 3-speed fan control

The WSHP Open controller is capable of controlling up to three fan speeds. The motor will operate at the lowest speed possible to provide quiet and efficient fan operation with the best latent capability. The motor will increase speed if additional cooling or heating is required to obtain the desired space temperature set point. The control increases the motor's speed as the space temperature rises above the cooling or below the heating set point. The amount of space temperature increase above or below the set point required to increase the fan speed is user configurable in the set point. Also, the control will increase the fan speed as the supply air temperature approaches the configured minimum or maximum limits.

NOTE: Three-speed fan control is not available with constant airflow ECM fan motors. Three-speed fan control is available only with constant torque ECM and PSC fan motors.

Fan speed control — during heating

Whenever heat is required and active, the control continuously monitors the supply air temperature to verify it does not rise above the configured Maximum Heating SAT Limit (110°F default). As the SAT approaches this value, the control will increase the fan speed as required to ensure the SAT will remain 5°F below the limit. This feature provides the most quiet and efficient operation by operating the fan at the lowest speed possible.

Fan speed control — during cooling

Whenever mechanical cooling is required and active, the control continuously monitors the supply air temperature to verify it does not fall below the configured Minimum Cooling SAT Limit (50°F default). As the SAT approaches this value, the control will increase the fan speed as required to ensure the SAT will remain 5°F above the limit. Fan will operate at lowest speed to maximize latent capacity during cooling.

Fan status (option)

An optional input can be configured as either an occupancy input contact or a fan status input. If configured as fan status, the controller will compare the status of the fan to the desired commanded state. Whenever the fan is commanded to run (ON), the fan status will be checked and verified to match the commanded state. If the fan status is not on, then a fan status alarm will be generated after 1 minute and the equipment's compressor(s) and auxiliary heat will be disabled and the optional OA (outdoor air) damper will close (if equipped).

Cooling

The WSHP Open controller will operate one or two stages of compression to maintain the desired cooling set point. The compressor outputs are controlled by the PI (proportional-integral) cooling loop and cooling stages capacity algorithm. They will be used to calculate the desired number of stages needed to satisfy the space by comparing the

space temperature (SPT) to the appropriate cooling set point. The water side economizer, if applicable, will be used for first stage cooling in addition to the compressor(s). The following conditions must be true in order for the cooling algorithm to run:

- Cooling is set to Enable
- The Fire/Smoke Input and Shutdown modes are inactive
- Heat mode is not active and the compressor time guard(s) have expired
- Condensate Overflow input is Normal
- Fan Status is true (if option is enabled)
- If occupied, the SPT is greater than the occupied cooling set point
- Space temperature reading is valid
- If unoccupied, the SPT is greater than the unoccupied cooling set point.
- If economizer cooling is available and active and the economizer alone is insufficient to provide enough cooling.
- OAT is greater than the cooling lockout temperature if OAT is available
- Condenser water pump is on (if condenser water linkage active)

If all the above conditions are met, the compressors will be energized as required, otherwise they will be de-energized. If cooling is active and should the SAT approach the minimum SAT limit, the fan will be indexed to the next higher speed. Should this be insufficient and if the SAT falls further (equal to the minimum SAT limit), the fan will be indexed to the maximum speed. If the SAT still continues to fall 5°F below the minimum SAT limit, all cooling stages will be disabled.

During Cooling, the reversing valve output will be held in the cooling position (either B or O type as configured) even after the compressor is stopped. The valve will not switch position until the heating mode is required.

The configuration screens contain the Min SAT parameter as well as cooling lockout based on outdoor air temperature (OAT), both can be adjusted to meet various specifications.

There is a 5-minute off time for the compressor as well as a 5-minute time delay when staging up to allow the SAT to achieve a stable temperature before energizing a second stage of capacity. Likewise, a 45-second delay is used when staging down.

After a compressor is staged off, it may be restarted again after a normal time-guard period of 5 minutes and if the supply air temperature has increase above the minimum supply air temperature limit.

The WSHP Open controller provides a status input to monitor the compressor operation. The status is monitored to determine if the compressor status matches the commanded state. This input is used to determine if a refrigerant safety switch or other safety device has tripped and caused the compressor to stop operating normally. If this should occur, an alarm will be generated to indicate the faulted compressor condition.

Reverse cycle heating

The WSHP Open controller will operate one or two stages of compression to maintain the desired heating set point. The compressor outputs are controlled by the heating PI (proportional-integral) loop and heating stages capacity algorithm. They will be used to calculate the desired number of stages needed to satisfy the space by comparing the space temperature (SPT) to the appropriate heating set point. The following conditions must be true in order for the heating algorithm to run:

- Heating is set to Enable
- The Fire/Smoke Input and Shutdown modes are inactive
- Cool mode is not active and the compressor time guard has expired
- Condensate Overflow input is Normal
- Fan Status is true (if option is enabled)
- If occupied, the SPT is less than the occupied heating set point
- Space temperature reading is valid
- If unoccupied, the SPT is less than the unoccupied heating set point
- OAT is less than the heating lockout temperature if OAT is available.
- Condenser water pump is on (if condenser water linkage active)

If all the above conditions are met, the heating outputs will be energized as required, otherwise they will be de-energized. If the heating is active and should the SAT approach the maximum SAT limit, the fan will be indexed to the next higher speed. Should this be insufficient, then if the SAT rises further and reaches the maximum heating SAT limit, the fan will be indexed to the maximum speed. If the SAT still continues to rise 5°F above the maximum limit, all heating stages will be disabled.

During Heating, the reversing valve output will be held in the heating position (either B or O type as configured) even after the compressor is stopped. The valve will not switch position until the cooling mode is required.

The configuration screens contain the Max SAT parameter as well as heating lockout based on outdoor air temperature (OAT), both can be adjusted to meet various specifications.

There is a 5-minute off time for the compressor as well as a 5-minute time delay when staging up to allow the SAT to achieve a stable temperature before energizing a second stage of capacity. Likewise, a 45-second delay is used when staging down.

After a compressor is staged off, it may be restarted again after a normal time-guard period of 5 minutes and if the supply air temperature has fallen below the maximum supply air temperature limit.

The WSHP Open controller provides a status input to monitor the compressor operation. The status is monitored to determine if the compressor status matches the commanded state. This input is used to determine if a refrigerant safety switch or other safety device has tripped and caused the compressor to stop operating normally. If this should occur, an alarm will be generated to indicate the faulted compressor condition. Also, if auxiliary heat is available (see below), the auxiliary heat will operate to replace the reverse cycle heating and maintain the space temperature as required.

Auxiliary heat

Single stage electric auxiliary heat

The control can operate a single stage of electric heat installed on the discharge side of the unit in order to maintain the desired heating set point should the compressor capacity be insufficient or a compressor failure occurs. Unless a compressor fault condition exists, the heat stage will only operate to supplement the heat provided by the compressor if the space temperature falls more than one degree below the desired heating set point. The heat stage will be controlled so the SAT will not exceed the Maximum Heating SAT limit and subject to a two-minute minimum OFF time to prevent excessive cycling. Should the compressor(s) fail to operate and heating is required, the auxiliary heat will operate as required to maintain the space temperature set point.

Indoor air quality (IAQ) and demand controlled ventilation (DCV)

If the optional indoor air quality sensor is installed or the network input point “System Space AQ” is utilized, the WSHP Open controller can maintain indoor air quality, with a field-installed modulating OA damper providing demand controlled ventilation. The control operates the modulating OA damper during occupied periods. The control monitors the CO₂ level and compares it to the configured set points and adjusts the ventilation rate as required. The control provides proportional ventilation to meet the requirements of ASHRAE specifications by providing a base ventilation rate and then increasing the rate as the CO₂ level increases. The control will begin to proportionally increase ventilation when the CO₂ level rises above the start ventilation set point and will reach the full ventilation rate when the CO₂ level is at or above the maximum set point. A user configurable minimum damper position ensures that proper base ventilation is delivered when occupants are not present. The IAQ configurations can be accessed through the configuration screen. The following conditions must be true in order for this algorithm to run:

- Damper control is configured for DCV.
- The Fire/Smoke Input and Shutdown modes are inactive.
- Fan Status is true (if option is enabled).
- The unit is in an occupied mode.
- IAQ sensor reading is greater than the DCV Start Control set point.

The control has four user-adjustable set points: DCV start control set point, DCV Maximum Control set point, Minimum damper position and the DCV Maximum damper position.

NOTE: In order for the damper to maintain proper base ventilation, the fan must be configured to operate in either the Continuous or Always On mode.

Two-position OA damper

The control can be configured to operate as a ventilation damper in a 2-position ventilation mode to provide the minimum ventilation requirements during occupied periods. This control operation still utilizes the modulating damper actuator.

Dehumidification with hot gas reheat (HGRH)

The WSHP Open controller will provide occupied and unoccupied dehumidification only on units that are equipped with the factory-installed HGR option. This function requires an accessory space relative humidity sensor. When using a relative humidity sensor to control dehumidification during occupied or unoccupied times, the dehumidification set points are used accordingly. Additionally, the network input point “System Space RH” may also be used in place of the hard wired RH (relative humidity) sensor. When the indoor relative humidity becomes greater than the dehumidification set point a dehumidification demand will be acknowledged. As long as heating or cooling is not currently active, dehumidification will be energized, bringing on the supply fan (medium speed), mechanical cooling, and the integral refrigerant hot gas reheat coil. The controls will engage cooling mode, start the compressor if not already operating, and waste heat from the compressor cooling cycle will be diverted to the reheat coil. The reversing valve will be positioned to operate the compressor in the cooling mode. If a call for sensible cooling takes place during hot gas reheat operation, the hot gas reheat is de-energized and the reheat operation is turned off. Once the call for cooling has been satisfied and if there is still a need for dehumidification, the unit will continue to operate in a dehumidification mode with the compressor providing cooling and the refrigerant reheat energized.

Waterside economizer

The WSHP Open controller has the capability of providing two-position waterside economizer operation (economizer coil is mounted to the entering air side of the unit and connected to the condenser water loop) in order to be used to provide free cooling (or preheating) when water conditions are optimal. Water economizer settings can be accessed through the equipment status screen. The following conditions must be true for economizer operation:

- SAT reading is available.
- EWT reading is available.
- If occupied, the SPT is greater than the occupied cooling set point or less than the occupied heating set point and the condenser water temperature is suitable.
- Space temperature reading is valid.
- If unoccupied, the SPT is greater than the unoccupied cooling set point or less than the unoccupied heating set point and the condenser water temperature is suitable.

Two-position water economizer control

The control has the capability to control a normally open or normally closed, two-position water valve to control condenser water flow through a coil on the entering air side of the unit.

Cooling

The purpose is to provide a cooling economizer function directly from the condenser water loop when the entering water loop temperature is suitable (at least 5°F below space temperature). If the optional coil is provided and the water loop conditions are suitable, then the valve will open to provide cooling to the space when required. Should the capacity be insufficient for a period greater than 5 minutes, or should a high humidity condition occur, then the compressor will be started to satisfy the load. Should the SAT reach the Minimum Cooling SAT limit, the economizer valve will close during compressor operation.

Heating

Additionally, the economizer control will open the water valve should the entering water loop temperature be suitable for heating (at least 5°F above space temperature) and heat is required. The valve will be controlled in a similar manner except to satisfy the heating requirement. Should the coil capacity be insufficient to satisfy the space load for more than 5 minutes, then the compressor will be started to satisfy the load. Should the SAT reach the Maximum Heating SAT limit, the economizer valve will close during compressor operation.

Demand limit

The WSHP Open controller has the ability to accept three levels of demand limit from the BACnet network. In response to a demand limit, the unit will decrease its heating set point and increase its cooling set point to widen the range in order to immediately lower the electrical demand. The amount of temperature adjustment in response is user adjustable for both heating and cooling and for each demand level. The response to a particular demand level may also be set to zero.

Power failure restart delay

The control provides a user configurable delay when recovering from a power failure or SHUTDOWN mode or when transitioning from unoccupied to occupied mode in order to prevent excessive demand when many units start simultaneously. Each unit can be user configured for a unique delay between 5 and 600 seconds. The factory programmed default delay is 180 seconds.

Fire/smoke detector alarm

The control monitors the voltage input to J1-9 to detect if a smoke detector or fire detector Normally Closed contact has opened, indicating an alarm condition. The control will verify the presence of 24 vac on this input. If the input should open at any time, an alarm will be generated after 3 seconds and the equipment (fan, compressor, auxiliary heat and damper) will immediately return to an OFF or closed state.

Space temperature alarms

The control provides the ability to generate an alarm whenever the space temperature exceeds the alarm set point. A separate occupied hysteresis and fixed unoccupied high and low alarm set points are provided. The control provides a 5-minute alarm delay during unoccupied periods. During occupied periods, the control uses the occupied temperature set points and applies the hysteresis value to determine the alarm set points. Whenever an occupancy transition from unoccupied to occupied occurs or the occupied temperature set points are changed causing an alarm condition to occur, the control will automatically calculate an alarm delay (equivalent to the configured delay time in minutes per degree F times the temperature error that occurred plus 15 minutes). This will prevent nuisance alarms whenever an occupancy change occurs and allows time for the unit to correct an alarming temperature condition.

Condenser water temperature alarm

The control has 4 configurable alarm limits for condenser water temperature. The control will verify that the water temperature is within operating range (between high and low limits) for the specific operating mode (heating or cooling) before energizing the compressor. Once the compressor is started, the condenser water temperature is further monitored to verify that it is within limits to ensure sufficient water is flowing through the coil. Should the leaving water temperature rise above or fall below the appropriate limits,

and alarm is generated and the compressor will be shut down if the condition occurs for more than 15 seconds.

Supply air temperature alarm

The control has 2 configurable alarm limits for supply air temperature. The control will verify that the supply air temperature is within operating range (between high and low limits) whenever the compressor or auxiliary heat is operating. Should the air temperature rise above or fall below the appropriate limit, an alarm is generated if the condition occurs for more than 1 minute.

High condensate/overflow alarm

The control will monitor a discrete input to determine the state of a condensate level switch. The input can be configured to alarm on either an open or closed switch condition. Should this input be in an alarm state, the control will start a timer and after the timer exceeds a configurable Condensate Overflow Alarm Delay limit (10-second default), the control will generate an alarm and the unit will disable the compressor and fan outputs.

Fan status alarm (optional)

The control generates a fan status alarm should the fan status input detect the fan is OFF after any fan speed output has been enabled. A 30-second alarm delay is used to allow the fan sufficient time to start operating before an alarm condition is detected. The control monitors the fan output and if the fan is operating at any speed, the fan status must detect the fan is operating.

Compressor status alarm

The control generates a compressor failure alarm should the compressor status input detect the compressor is OFF after the compressor output has been energized. A 6-minute alarm delay is used to allow the compressor to start (prevents alarms due to time guard operation) before an alarm condition is detected. The control monitors the compressor output and if the compressor output is energized, the compressor status input must detect the compressor operation.

Filter status alarm

The control provides the ability to generate a dirty filter alarm after the number of fan run hours exceeds a configurable filter alarm timer limit. The control monitors the fan output and if the fan is operating at any speed, it accumulates run time. Should the fan run time hours exceed the configurable limit, an alarm is generated. To reset the alarm timer after the alarm has been generated, a Reset Filter Alarm input is provided. The filter alarm can be disabled by setting the Filter Alarm Timer Delay to zero (factory default).

Indoor air quality alarm

The control provides the ability to generate a high CO₂ level alarm during occupied periods whenever the CO₂ sensor value exceeds the user adjustable limit. Whenever an occupancy transition from unoccupied to occupied occurs, or the occupied alarm limit is changed to a value that causes an alarm condition to occur, the control will automatically calculate an alarm delay:

$$\frac{\text{the configured delay time in minutes}}{\text{ppm times the error that occurred}} + 15 \text{ minutes}$$

This prevents nuisance alarms from occurring when occupancy changes or set point is changed. The IAQ alarm can be disabled by setting Occupied High IAQ Alarm Limit to zero.

Relative humidity alarm

The control provides the ability to generate an alarm whenever the space relative humidity exceeds the alarm set point. Separate occupied and unoccupied high humidity alarm set points are provided. The control provides a 5-minute alarm delay during unoccupied periods. During occupied periods, the controller uses the occupied high RH alarm limit. Whenever an occupancy transition from unoccupied to occupied occurs, or the occupied high alarm limit is lowered causing an alarm condition to occur, the control will automatically calculate an alarm delay:

$$\frac{\text{the configured delay time in minutes}}{\% \text{ RH times the humidity error condition that occurred}} + 15 \text{ minutes}$$

This will prevent nuisance alarms whenever an occupancy change occurs and allows time for the unit to correct an alarming humidity condition.

Condenser water linkage failure alarm (if condenser water linkage was active)

The control generates a condenser water linkage failure alarm should linkage fail after once being active. The linkage status is monitored and should it fail to be updated from the Loop Controller, then a Condenser Water Linkage alarm is generated. A 6-minute alarm delay is provided to prevent false alarm from occurring.

NOTE: This alarm can only be reset by re-establishing linkage and correcting the condition that caused the linkage failure to occur or by setting the SHUTDOWN point to Active momentarily.

Airside linkage failure alarm (if airside linkage was active)

The control generates an airside linkage failure alarm should linkage fail after once being active. The linkage status is monitored and should it fail to be updated from the Master Zone Controller, then an Airside Linkage alarm is generated. A 6-minute alarm delay is provided to prevent false alarm from occurring.

NOTE: This alarm can only be reset by re-establishing linkage and correcting the condition that caused the linkage failure to occur or by setting the SHUTDOWN point to Active momentarily.

OAT sensor alarm (if network OA temperature was active)

The control generates an OAT sensor failure alarm should the value of OAT fail to be updated through the network after once being active. The update status is monitored and should it fail to be updated, then an OAT sensor alarm is generated. An alarm delay (approximately 1 hour) is provided to prevent false alarm from occurring while minimizing the required update rate for OAT.

NOTE: This alarm can be reset by setting the SHUTDOWN point to Active momentarily.

ZS sensor alarm (if ZS sensor was active)

The control generates a ZS sensor failure alarm should the ZS sensor fail to communicate with the control. The update status is monitored and should it fail to be updated, then the alarm is generated.

Single-Stage Water Source Heat Pumps with Puron® Refrigerant (R-410A)

HVAC Guide Specifications (Water Loop)

Size Range: **6,800 to 70,000 Btuh**

Cooling Capacity

8,800 to 86,000 Btuh

Heating Capacity

Carrier Model Number: **50PSH, 50PSV**

Part 1 — General

1.01 SYSTEM DESCRIPTION

- A. Single package horizontally and vertically mounted water source heat pumps with Puron® refrigerant (R-410A) and electronic controls.
- B. Equipment shall be completely assembled, piped and internally wired. Capacities and characteristics as listed in the schedule and the guide specifications that follow.

1.02 QUALITY ASSURANCE

- A. All equipment shall be rated and certified in accordance with ANSI/AHRI/ASHRAE/ISO (American National Standards Institute/Air-Conditioning, Heating and Refrigeration Institute/American Society of Heating, Refrigerating, and Air-Conditioning Engineers/International Organization for Standardization) 13256-1 performance standard, latest edition and ETL listed to UL (Underwriters Laboratories) standard 1995. The units shall have AHRI/ISO and ETL labels.
- B. All units shall be fully quality tested by factory run testing under normal operating modes and safety switch operation shall be verified.
- C. Serial numbers will be recorded by factory and furnished to contractor on report card for ease of unit warranty status. Units shall be prewired and pre-charged in factory.

Part 2 — Product

2.01 EQUIPMENT

A. General:

Units shall be supplied completely factory built for an entering water temperature range from 50 to 100°F as standard, from 40 to 110°F in cooling mode and 20 to 80°F in heating mode. Any operation below 60°F or above 100°F should use extended range option. Units may consist of rotary or scroll compressor, PSC (permanent split capacitor), constant torque ECM (electronically commutated motor) or constant airflow ECM fan motor and blower and refrigerant circuit as indicated on the equipment schedule. Equivalent units from other manufacturers can be proposed provided approval to bid is given 10 days prior to bid closing.

B. Basic Construction:

1. Units shall have the airflow arrangement as shown on the plans. If units with these arrangements are not used, the contractor supplying the water source heat pumps is responsible for

any extra costs incurred by other trades and must submit detailed mechanical drawings showing ductwork requirements and changes or relocation of any other mechanical or electrical system. If other arrangements make servicing difficult the contractor must provide access panels and clear routes to ease service. The architect must approve all changes 10 days prior to bid.

2. All units shall have stainless steel drain pans to comply with this project's IAQ (indoor air quality) requirements. No exceptions shall be allowed.
3. The cabinet shall be fabricated from 18-ga G-90 galvanized steel for superior corrosion protection. All interior surfaces shall be lined with 1/2 in. thick, multi-density, coated, fiberglass insulation. Insulation must be non-combustible, non-hydroscopic and anti-fungal. Insulation must meet NFPA (National Fire Protection Association) 90A and 90B for fire protection as well as Fire Hazard classification 25/50 (per ASTM [American Society for Testing and Materials] E84 and UL 723 and CAN/ULC S102-M88), ASTM C1071, erosion requirements of UL181 and be certified to meet GREENGUARD indoor air quality standards for low emitting products. One blower access panel and two compressor compartment access panels shall be removable with supply and return air ductwork in place.
4. Unit shall be equipped with double compressor isolation. The unit shall have a floating basepan consisting of the compressor mounted on rubber grommets and a heavy gage steel plate supported by a 1/2 in. thick, high density rubber pad on the base of the unit to prevent transmission of vibration to the structure.
5. All units shall have a factory-installed four-sided filter rack capable of accepting either one or 2-in. filters. Units shall have a 1-in. thick throw-away type fiberglass filter as standard. The filter rack shall incorporate a 1-in. duct flange. The contractor shall purchase one spare set of filters and replace factory-shipped filters upon completion of start-up.
6. Cabinets shall have separate holes and knock-outs for entrance of line voltage and low voltage control wiring. Supply and return water connections shall be brass FPT fittings and shall be securely mounted flush to the cabinet allowing for connection to a flexible hose without the use of a back-up wrench. Water connections which protrude through the cabinet shall not be allowed.
7. Hanging brackets shall be provided as standard for horizontal units.
8. Condensate overflow protection sensor shall activate a circuit upon sensing when a high level of condensate water is in the drain pan resulting

in a hard lockout in the unit. Freeze protection sensors shall be provided on both sides of the refrigeration circuit. Sensors that measure water temperature shall not be allowed.

C. Compressor:

1. The compressor shall have a dual level vibration isolation system.
2. The compressor will be mounted on vibration isolation grommets to a large heavy gage compressor mounting tray plate, which is then isolated from the cabinet base with rubber grommets for maximized vibration attenuation.
3. Compressor shall be located in an insulated compartment away from airstream to minimize sound transmission.
4. Compressor shall have thermal overload protection.

D. Fan and Motor Assembly:

1. The fan shall be direct-drive centrifugal forward curved type with a dynamically balanced wheel. The housing and wheel shall be designed for quiet low velocity operation. The blower housing shall feature a removable inlet ring to facilitate removal and servicing of the fan motor. The fan motor shall be 3-speed, permanently lubricated, PSC type with thermal overload protection on unit sizes 1/2 through 1 ton.
2. Unit sizes 1-1/4 through 6 tons shall have a constant torque ECM for premium fan efficiency. These motors shall feature 3 pre-programmed torque settings that can be changed in the field to match design requirements. 460 v, 3 ph, 60 Hz units with these motors must be able to operate without the need for a neutral wire for the motor.
3. Unit sizes 1-1/4 through 6 tons shall have an optional constant airflow ECM.
4. The fan motor shall be isolated from the housing by torsionally flexible isolation.
5. The fan and motor assembly must be capable of overcoming the external static pressures (ESP) as shown on the schedule. ESP rating of the unit shall be based on a wet coil. Ratings based on a dry coil will NOT be acceptable.

E. Refrigerant Circuit:

1. Hermetic compressor: Hermetic rotary or scroll compressors shall be specifically designed for R-410A refrigerant, shall be thermally protected, and shall be located in an insulated compartment to minimize sound transmission.
2. Access fittings shall be factory-installed on high and low pressure refrigerant lines to facilitate field service.
3. Refrigerant metering shall be accomplished by thermostatic expansion valve only.
4. Finned tube refrigerant-to-air heat exchanger not exceed 16 fins per inch. Refrigerant-to-air heat exchangers shall utilize enhanced

aluminum fins an rifled copper tube construction rated to withstand 600 psig refrigerant working pressure. All air coils shall have non-ferrous aluminum end plates.

5. A corrosion protection option for refrigerant-to-air heat exchangers that features tin plating of the copper tubing and coating of the aluminum fins with a protective film. The tin plating provides best in class protection of the copper tubing from formicary corrosion while the fin coating provides protection against salt spray and other corrosive elements. Protected coils can exceed 1000 hours salt spray per ASTM standard B-117.
6. Coaxial (tube in tube) refrigerant-to-water heat exchanger: Refrigerant-to-water heat exchangers shall be of copper inner water tube and steel outer refrigerant tube design rated to withstand 600 psig working refrigerant pressure and 450 psig working water pressure. Shell and tube style refrigerant-to-water heat exchangers shall be treated as pressure vessels and shall require refrigerant pressure relief valves piped to the exterior of the building. Brazed plate water-to-refrigerant heat exchangers shall require additional centrifugal separators added to the supply water piping at each unit. Each separator shall have an automated cleanout valve piped to a waste line. The contractor supplying water source heat pumps with brazed plate heat exchangers shall be responsible for any additional costs.
7. Optional CuNi water coil – The refrigerant-to-water heat exchanger shall have inner tube constructed of cupronickel.
8. Refrigerant safety controls shall include both high and low pressure safety switches. Temperature sensors shall not replace these safety switches.

F. Drain Pan:

1. The drain pan shall be constructed of 304 stainless steel to inhibit corrosion.
2. Drain pan shall be fully insulated.
3. Drain outlet shall be located at pan as to allow complete and unobstructed drainage of condensate. Drain outlet for horizontal units shall be connected from pan directly to FPT fitting. No hidden internal tubing extensions from pan outlet extending to unit casing (that can create drainage problems) will be accepted.
4. The unit as standard will be supplied with solid-state electronic condensate overflow protection. A mechanical float switch will be used with Complete C package.

G. Controls and Safeties:

1. Electrical:
A control box shall be located within the unit and shall contain a transformer, controls for the

compressor, reversing valve and fan motor operation and shall have a terminal block for low voltage field wiring connections. The transformer shall be rated for a minimum 75 va. All units shall be nameplated for use with time delay fuses or HACR (Heating, Air-Conditioning, and Refrigeration) circuit breakers. Unit controls shall be 24 volts.

All transformers shall have a push button reset circuit breaker on the secondary power.

2. Unit Protection Module (UPM):

All units shall have a solid-state safety control circuit with the following features:

- a. Anti-short cycle time delay on compressor operation, with a 5-minute delay.
- b. Random start on power up mode.
- c. Brownout / surge / power interruption protection.
- d. Low pressure switch 120-second bypass timer.
- e. Shutdown on the following fault indications:
 - 1) High or low refrigerant pressure safety switches inputs.
 - 2) Low water temperature shutdown. Freeze sensors shall monitor refrigerant temperature to the water coil in the heating mode and shall activate the lockout circuit when water temperature drops below either 15°F or 35°F depending on the selection. 15°F is field selectable for installations utilizing anti-freeze.
 - 3) Condensate overflow protection. A condensate sensor shall activate the lockout circuit upon sensing a high level of condensate in the drain pan and immediately put the unit into a hard lockout. Condensate overflow protection (COP) shall be standard on all units.
 - 4) Air coil freeze protection shut down refrigerant coil in the cooling modes.
- f. Alarm output which closes for selectable dry contact closure or 24 vac remote fault indication.
- g. Alarm output selectable for constant output for general alarm notification, or pulse output for annunciation of the specific fault alarm.
- h. Activation of any safety device shall prevent compressor operation via a lockout circuit. The lockout circuit shall be reset at the thermostat or at the contractor supplied disconnect switch. Units which may be reset at the disconnect switch only shall not be acceptable.
- i. Automatic intelligent reset. Unit shall automatically reset after a safety shut down and

restart after the anti-short cycle timer and random start timer expire. Should a fault re-occur within 60 minutes after reset, then a permanent lockout will occur. Reset attempts shall be selectable for either 2 or 4 tries. A condensate overflow will place the unit in an immediate hard lockout.

- j. Ability to defeat time delays for servicing.
- k. A light-emitting diode (LED) to indicate safety alarms. The LED shall annunciate the following alarms:
 - 1) High refrigerant pressure,
 - 2) Low refrigerant pressure,
 - 3) Low refrigerant temperature to the water coil in the heating operation,
 - 4) High level of condensate in the drain pan,
 - 5) Brown out/surge/power interruption.
- l. The LED will display each fault condition as soon as the fault occurs. If a permanent lockout occurs, then the fault LED will display the type of fault until the unit is reset.
- m. UL listed, UL Canada listed, and RFI, ESD, and transient protected.
- n. Low refrigerant temperature to the air coil in cooling operation.

3. Safety devices:

- a. Low pressure cutout set at 40 psig for loss of charge protection (freezestat and/or high discharge gas temperature sensor is not acceptable).
- b. High pressure cutout control set at 600 psig.
- c. Low supply water temperature sensor protection which monitors refrigerant temperature that could result in water heat exchanger freezing.
- d. Low air coil temperature sensor protection which monitors refrigerant temperature that could result in air heat exchanger freezing.
- e. High level of condensate sensor that shuts off the compressor if the condensate drain pan fills with water.
- f. On board voltage detection that disables the compressor control circuit if there are extreme variations exceeding $\pm 10\%$ in supply voltage.

4. Deluxe D Control Package:

Optional electronic Deluxe D control package shall have all the features of the Complete C control package with the following additional features:

- a. Pump-valve relay to enable a pump/valve operation when calling for compressor operation.
- b. Energy management switch to enable remote operation of WSHP (water source heat pump).

- c. Phase monitor to protect the compressor from operating in reverse rotation on three phase units.
 - d. Boilerless control shall activate an electric heater (internal or external unit) and disable compressor should water temperature drop below set point. Includes a relay and splitting the power supply to the unit into a blower motor and control power supply and a compressor power supply. The relay (when energized) deactivates the compressor control circuit.
5. WSHP Open Multiple Protocol Control:
- a. Units shall have all the features above (Complete C package) and the state of the art WSHP Open multiple protocol interface board will have the ability to be viewed in the Equipment Touch™, System Touch™, or field assistant user interface. All point objects will have the ability to be viewed in the Equipment Touch user interface. The following points must be available at a central or remote computer location:
 - 1) Space temperature
 - 2) Leaving water temperature
 - 3) Discharge air temperature
 - 4) Command of space temperature set point
 - 5) Cooling status
 - 6) Heating status
 - 7) Low temperature sensor alarm
 - 8) High pressure switch alarm
 - 9) Fan on/off position of space thermostat
 - 10) Unoccupied/occupied command
 - 11) Cooling demand
 - 12) Heating demand
 - 13) Fan “ON/AUTO” command
 - 14) Fault prevention with auto reset
 - 15) Itemized fault code viewed with Equipment Touch interface
 - b. Additional WSHP Open multiple protocol control features shall include:
 - 1) Three-speed fan control. Controller shall automatically, based upon space temperature input, operate the fan at the lowest of 3 selectable speeds to achieve space temperature set point.
 - 2) Two-position OA (outdoor air) damper
 - 3) Modulating OA damper with DCV (demand controlled ventilation)
 - 4) Hot gas reheat solenoid valve
 - 5) Two-position water economizer control
 - 6) Modulating water economizer control
 - 7) Single stage electric auxiliary heat
 - 8) Power fail restart delay
6. Multiple-protocol WSHP Open controller remote ZS sensors for DDC (direct digital controls) control options. Only Carrier ZS sensors can be used with the WSHP Open controller. Sensors are available as follows, and all sensors below offer monitoring of space temperature only, or space temperature and CO₂, or space temperature and humidity, or space temperature and CO₂ and humidity.
- a. ZS Standard sensor with a communication port.
 - b. ZS Plus sensor with communication port, occupancy status indicator, local occupancy override and set point adjustment.
 - c. ZS Pro sensor with communication port, occupancy status indicator, local occupancy override, set point adjustment, LCD (liquid crystal diode) display, alarm indicator and fan speed control
 - d. ZS Pro-F sensor with communication port, occupancy status indicator, local occupancy override, set point adjustment, LCD display, alarm indicator, fan speed control, cooling/heating/fan only mode control and F to C conversion.
- H. Factory-Installed Options:
- 1. Mute Package:

Optional compressor blanket shall be provided on units having a capacity above 24,000 Btuh.
 - 2. Hot Gas Reheat:

Units as noted on the schedule shall be equipped with optional hot gas reheat (HGRH). On/Off HGRH shall be controlled by a humidistat connected to the unit H terminal and shall start the unit in the reheat mode should the humidity be above set point once the thermostat control is satisfied. Cooling or heating requirements shall take precedence over HGRH.
 - 3. Unit-Mounted Disconnect:

A non-fused factory mounted disconnect shall be installed on the unit.
 - 4. Two-Way Motorized Solenoid Valve:

A two-way motorized solenoid valve shall be mounted in the interior of the unit. The valve shall cycle open whenever there is a call for compressor operation. The valve shall be equipped with an end switch. The two-way motorized solenoid valve is rated for a 300 psig working pressure.
 - 5. Electric Heat:

Factory-installed UL listed electric heater packages shall be available for the units. Available only on vertical units with top discharge and horizontal units with end blow configuration, and on 208/230-1 and 208/230-3 units.

Guide specifications (cont)

6. Extended Range Option:

Coaxial refrigerant to water heat exchanger shall be insulated to allow for geothermal applications.

7. Filters:

All units shall have a factory-installed four-sided filter rack with access panel and either 2 in. MERV 8 filter or MERV 13 pleated filter. (MERV 13 option available only on sizes 015-070 and with ECM option.)

8. Hot Gas Bypass:

Supply each unit with a ETL listed and MEA listed modulating hot gas bypass valve with factory-supplied and installed controls to prevent air coils from frost development by taking hot gas and bypassing the water coil and expansion device and reintroducing the hot gas into the refrigerant line prior to the air coil. The hot gas bypass valve shall maintain a minimum refrigerant suction pressure to allow for a light load cooling mode or a low entering air temperature.

9. Hot Water Generator:

Hot Water Generator 208/230 V-1 Ph-60 Hz and 208/230 V-3 Ph-60 Hz units shall be equipped with factory installed internal heat recovery kit for domestic hot water production. This kit shall include an internally protected hot water circulation pump, copper double wall vented coaxial water-to-refrigerant heat exchanger, 140°F hot water temperature limit switch and an on/off switch/circuit breaker.

10. Closed Cell Foam:

Closed cell foam (CCF) shall be installed on interior surfaces of water source heat pump and shall meet the density and compression requirements of ASTM D 1056, the water absorption requirements of ASTM D-1667 and the tensile and elongation requirements of ASTM D-412. Closed cell foam shall meet the flammability requirements of FMVSS302 and UL 94.

11. Autoflow Regulator:

Autoflow regulator units shall have an optional water flow regulating valve set to 3 gallons per minute of water flow per nominal ton of refrigeration capacity.

I. Accessories:

1. Hose Kits and valves:

All units shall be connected to main water supply and return headers with hoses. The hoses shall be 2 or 3 feet long, braided stainless steel rated to 400 psig at 265°F. Hoses may contain optional ball valves with P/T ports,

Y strainers with blow down valves and/or out-flow regulators as specified in the schedule.

2. Electric Duct Heaters:

a. Duct heater shall be slip-in type and shall be UL approved for zero clearance to combustible surfaces. The heater shall bear a UL/CSA label. Control panel and element housing shall be constructed of heavy gage galvanized steel. All heating elements shall be made of nickel/chromium resistance wire with ends terminated by means of staking and heliarc welding to machine screws. Heating element support structure shall consist of galvanized steel wire formed and constructed to support ceramic bushings through which the heating element passes. Control cabinet shall be constructed of heavy gage galvanized steel with multiple knockouts for field wiring. Control cabinet shall have a solid cover also of heavy gage galvanized steel and held in place with hinges and tool-release latches.

b. Duct heater shall be supplied with primary over temperature protection by built in disc type automatic reset thermal cutouts and secondary over temperature protection by built in disc type manually resettable thermal cutouts. These devices must function independently of one another and are not acceptable if series connected in the control circuit wiring. A disconnecting magnetic control circuit is required. All duct heaters will require either a fan interlock circuit or an airflow switch.

c. Over-current protection by means of factory-installed fusing within the control cabinet shall be provided for heaters rated at more than 48 amps. Heating elements shall be subdivided and fused accordingly.

d. All wiring, component sizing, component spacing and protective devices within the control cabinet shall be factory installed and comply with NEC and UL standards. All heaters shall function properly with a 60 Hz power supply.

e. A wiring diagram depicting layout and connections of electrical components within the control cabinet shall be affixed to the inside of the control cabinet cover.

f. A rating plate label shall be affixed to the exterior of the control cabinet cover which states model number, serial number, volts, amps, phase, frequency, control volts, volt-amps and minimum airflow requirements.