



Product Data

Commercial Split Systems Air Conditioning Condensing Units 6 to 25 Tons



38AXZ07,08,12,14 Shown

38AXZ, AXD 07-28 Single and Dual Circuit Condensing Units
with Puron Advance™ R-454B Refrigerant

Introducing Carrier's new Gemini™ air cooled condensing units with Puron Advance™ — offering maximum flexibility for even the most demanding jobs.

Major design features of 38AX air cooled condensing units include:

- Puron Advance (R-454B) refrigerant, which delivers a 75% reduction in global warming potential (GWP) compared to the original Puron. Puron Advance's GWP of 466 easily exceeds the EPA (Environmental Protection Agency) requirement of <700 GWP
- Single circuit, two-stage, and dual circuit, three-stage designs for maximum performance and flexibility in new construction and replacement situations
- Economical cooling designs with a rugged, dependable build
- Cooling capability up to 125°F (52°C) ambient and down to 35°F (2°C) ambient standard

Installation flexibility

Carrier knows that split system installations are never easy. For that reason 38AX units were designed with application flexibility in mind. With a variety of offerings in single circuit, two-stage 38AXZ models (two pipe) and dual circuit, three-stage 38AXD models (4 pipe), our condensing units can handle a variety of site design requirements. With piping guidelines similar to legacy R-410A and R-22 systems, replacements are easier than ever. All A2L dissipation equipment is pre-installed in the 40RL fan coil and works seamlessly with the 38AX condensing unit through standard thermostat connections.

38AX products can be mounted on grade, on rails, or on a roof, and can accommodate air handlers installed

above or below the condensing unit. That flexibility is perfect for decorative buildings like churches with pitched roofs where rooftop cooling equipment may not be practical or buildings that were originally designed without air conditioning.

Now, rather than mount an entire curb, all you need is a location to mount a fan coil and a few small holes for piping to pass through to keep occupants comfortable all year round. For complete product information and installation requirements, please consult the rest of this document and installation manuals.

Efficient operation

Our air-cooled condensing units are tested and designed with our matched 40RLA air handlers. This ensures reliable operation by minimizing issues with piping design and oil return. All systems are tested in accordance with AHRI standard 340/360 and offer IEERs up to 15.5. Increased IEER values help reduce overall operating cost and energy consumption.

Factory-installed options (FIOPs)

Pre-engineered and certified factory-installed options (FIOPs) minimize installation time at site, reducing installation cost.

FIOPs include:

- Low ambient controls which provide cooling operation down to -20°F (-29°C) ambient temperatures
- Non-fused disconnect
- Special coil coating coil protection
- Louvered hail guard

For situations where time is critical Carrier also offers a full line of field installed accessories to upgrade stocked equipment at site to meet customer needs.

Constructed for a long life

The 38AXZ single circuit and 38AXD dual circuit, air cooled condensing units are designed and built to last. Featuring our new Puron Advance™ R-454B refrigerant, our split systems can be customized to suit a variety of building designs. Where conditions require, special coil coatings and coil protection are available. Cabinets are constructed of pre-painted galvanized steel, delivering unparalleled protection from the environment to ensure long life, good looks, and reliable operation. Onboard Comfort Alert™¹ diagnostic controls are included standard to enhance system protection and reliability. When there is an issue, valuable diagnostic information is easily readable to get equipment back up and running fast.

Controls for performance dependability

The 38AX condensing units offer operating controls and components designed for dependable performance. The high efficiency hermetic scroll compressors are engineered for long life and durability and include vibration isolation for quiet operation. High-pressure switches protect the entire refrigeration system from abnormally high operating pressures and a low-pressure switch protects the system from loss of charge. These units also include anti-short-cycling protection, which helps to guard the units against compressor failure. All units include a crankcase heater to eliminate liquid slugging at start-up. Each unit comes standard with the Comfort Alert control system which provides:

- System Go LED indicator
- Fault LED indicator
- Compressor fault LED indicator
- Phase loss protection
- Phase reversal protection
- Safety pressure indicator
- Anti-short cycle protection

Innovative Carrier 40RLA packaged air handlers are custom matched to 38AXZ/D condensing units. The 40RLA Series has excellent fan performance, efficient direct-expansion (DX) coils, a unique combination of indoor-air quality features, and easy installation. Its versatility and state-of-the-art features help to ensure economical performance of the split system both now and in the future. See separate product data for more details.

1. Third-party trademarks and logos are the property of their respective owners.

Table of contents

Features/Benefits	2
Model Number Nomenclature	3
AHRI Capacity Ratings	4
Physical Data	5
Base Unit Dimensions	13
38AX, 40RL Options and Accessories	17
Typical Piping and Wiring Diagrams	20
Performance Data	33
Electrical Data	71
Application Data	74
Guide Specifications	75

Features/Benefits (cont)



Puron Advance™ features

In 2018, Carrier announced Puron Advance (R-454B) as our next generation refrigerant for light commercial products. With a GWP of 466 and similar working pressure and performance to R-410A, Puron Advance easily exceeds the EPA's new, stringent <700 GWP refrigerant requirement while minimizing unit redesign. Like other next generation refrigerants (R-32, etc.), R-454B is classified as an "A2L" refrigerant by ASHRAE (American Society of Heating, Refrigerating, and Air-Conditioning Engineers). This designation means that R-454B is "mildly flammable" under certain conditions. While this is a change from legacy "A1 — No Flame Propagation" refrigerants like Puron (R-410A), A2Ls

are still very low on the flammability scale and quite safe for use. A2L refrigerants are difficult to ignite and have an extremely low flame speed — much less so than natural gas, propane, or even rubbing alcohol. At Carrier, we are committed to safety. As such, all of our Puron Advance systems include a factory installed dissipation control board and leak sensor designed to last the lifetime of the unit. This system is certified to UL 60335-2-40 and designed to work right away, without any field configuration or wiring. In the event of a leak, these systems automatically identify and resolve the issue by safely dissipating the refrigerant to minimize risk to equipment, buildings, or occupants.

Economy and rugged dependability

The 38AXD condensing units and 40RLA air handlers have low initial cost and energy-efficient operation to continue to save building owners money. With code compliant two or three stage operation, and mechanically bonded coil fins to improve heat transfer, Carrier's split systems help ensure occupants are comfortable with minimal energy spend. Our die-formed galvanized steel panels help ensure structural integrity under all operating conditions for a long operating life. With large control boxes and readily accessible components, 38AX units are designed for maintenance. In the event a full replacement is necessary, units can often be found in inventory.

Model number nomenclature

1	2	3	4	5	6	7	8	9	10	11	12	13	14	15	16	17	18
3	8	A	X	D	T	1	2	A	0	A	6	-	0	A	0	A	0

Model Type

38AX = Carrier Condensing Unit
Puron Advance™ R-454B Refrigerant

Type of Coil

Z = Single Circuit¹
D = Dual Circuit²

Refrigerant Options

M = Single Circuit / Two-Stage Cooling³
N = Single Circuit / Two-Stage Cooling with Low Ambient³
T = Dual Circuit / Three-Stage Cooling⁴
U = Dual Circuit / Three-Stage Cooling with Low Ambient⁴

Nominal Tonnage

07 = 6 Tons
08 = 7.5 Tons
12 = 10 Tons
14 = 12.5 Tons
16 = 15 Tons
25 = 20 Tons
28 = 25 Tons

Not Used

A = Not Used

Not Used

0 = Not Used

NOTE(S):

- ¹ M and N refrigerant options only.
- ² T and U refrigerant options only.
- ³ Size 07, 08, 12, 14, 16, and 25 units only.
- ⁴ Size 12, 14, 16, 25, and 28 units only.

Packaging

0 = Standard

Electrical Options

A = None
C = Non-Fused Disconnect

Service Options

0 = None
1 = Un-powered Convenience Outlet
2 = Powered Convenience Outlet

Not Used

A = Place Holder

Base Unit Controls

0 = Base Electro-Mechanical Controls

Design Rev

- = Catalog Model No.
A = Initial Rev / Discrete Model No.

Voltage

1 = 575/3/60
5 = 208/230/3/60
6 = 460/3/60

Coil Options (RTPF)

A = Cu/Al
B = Precoat (Cu/Al)
C = E-Coat (Cu/Al)
E = Cu/Cu
M = Cu/Al with Louvered Hail Guard
N = Precoat (Cu/Al) with Louvered Hail Guard
P = E-Coat (Cu/Al) with Louvered Hail Guard
R = Cu/Cu with Louvered Hail Guard

AHRI Capacity Ratings^{a,b}

UNIT	COOLING STAGES	NOMINAL CAPACITY (tons)	NET COOLING CAPACITY (MBH)	TOTAL POWER (kW)	EER	IEER WITH 2-SPEED FAN
38AXZ(M,N)07/40RL07	2	6	70.0	5.8	12.0	15.5
38AXZ(M,N)08/40RL08	2	7.5	92.0	8.2	11.2	15.5
38AXZ(M,N)12/40RL12	2	10	117.0	10.4	11.2	15.5
38AXZ(M,N)14/40RL14	2	12.5	135.0	12.3	11.0	15.5
38AXZ(M,N)16/40RL16	2	15	184.0	16.7	11.0	14.3
38AXZ(M,N)25/40RL25	2	20	240.0	22.6	10.6	13.6
38AXD(T,U)12/40RL12	3	10	117.0	10.4	11.2	14.9
38AXD(T,U)14/40RL14	3	12.5	135.0	12.3	11.0	14.2
38AXD(T,U)16/40RL16	3	15	184.0	16.7	11.0	14.2
38AXD(T,U)25/40RL25	3	20	240.0	22.6	10.6	13.5
38AXD(T,U)28/40RL28	3	25	278.0	27.3	10.2	13.2

NOTE(S):

- a. Rated in accordance with AHRI Standard 340/360, as appropriate.
- b. Ratings are based on: Cooling Standard: 80°F (27°C) db, 67°F (19°C) wb indoor air temp and 95°F (35°C) db outdoor air temp.

LEGEND

- AHRI — Air Conditioning, Heating, and Refrigeration
- ASHRAE — American Society of Heating, Refrigeration, and Air-Conditioning, Inc.
- EER — Energy Efficiency Ratio
- IEER — Integrated Energy Efficiency Ratio



Sound Power Levels, dB

UNIT	COOLING STAGES	A-WEIGHT OCTAVE OUTDOOR SOUND (dB) ^a								
		TOTAL	63	125	250	500	1000	2000	4000	8000
38AXZ07	2	84.6	63.1	68.9	73.4	79.5	80.2	76.4	72.0	64.9
38AXZ08	2	84.6	63.1	68.9	73.4	79.5	80.2	76.4	72.0	64.9
38AXZ12	2	83.2	60.4	65.8	77.1	76.8	77.1	75.8	70.2	64.7
38AXD12	3	83.8	62.9	69.6	74.4	77.9	79.3	76.1	70.7	61.1
38AXZ14	2	82.6	60.5	65.1	70.3	77.2	78.0	75.4	71.2	63.9
38AXD14	3	85.2	64.8	68.9	71.4	82.8	79.0	74.2	69.0	61.9
38AXZ16	2	84.2	60.1	69.7	72.8	78.7	79.5	76.3	72.9	67.8
38AXD16	3	82.8	55.5	64.8	73.6	77.2	78.2	74.8	70.7	64.3
38AXZ25	2	82.6	60.5	65.1	70.3	77.2	78.0	75.4	71.2	63.9
38AXD25	3	85.2	64.8	68.9	71.4	82.8	79.0	74.2	69.0	61.8
38AXD28	3	88.2	67.8	71.9	74.4	85.8	82.0	77.2	72.0	64.8

NOTE(S):

- a. Outdoor sound data is measured in accordance with AHRI standard 270-2008.

LEGEND

- dB — Decibel

38AXZ*07-25 Single Circuit Models – Physical Data

UNIT	38AXZ(M,N)07	38AXZ(M,N)08	38AXZ(M,N)12	38AXZ(M,N)14	38AXZ(M,N)16	38AXZ(M,N)25
NOMINAL CAPACITY (tons)	6	7.5	10	12.5	15	20
OPERATING WEIGHT (lb)	389	430	490	598	731	978
Refrigeration System						
No. Circuits / No. Comp. / Type	1 / 1 / Scroll	1 / 1 / Scroll	1 / 1 / Scroll	1 / 2 / Scroll	1 / 2 / Scroll	1 / 2 / Scroll
Refrigerant Type	Puron Advance™ R-454B	Puron Advance™ R-454B	Puron Advance™ R-454B	Puron Advance™ R-454B	Puron Advance™ R-454B	Puron Advance™ R-454B
R-454B Shipping Charge A/B (lb, 60 Hz)	9.0	9.0	9.0	9.0	9.0	9.0
System Charge w/ Fan Coil^a (60 Hz)	15.5	16.4	18.2	26.1	34.0	36.5
Metering Device	TXV	TXV	TXV	TXV	TXV	TXV
High-press. Trip / Reset (psig)	630 / 505	630 / 505	630 / 505	630 / 505	630 / 505	630 / 505
Low-press. Trip / Reset (psig)	54 / 117	54 / 117	54 / 117	54 / 117	54 / 117	54 / 117
Compressor						
Oil Charge A/B (oz)	42	58	85	42 / 42	58 / 58	85 / 85
Speed (rpm, 60 Hz)	3500	3500	3500	3500	3500	3500
Condenser Coil						
Material	Al/Cu	Al/Cu	Al/Cu	Al/Cu	Al/Cu	Al/Cu
Coil Type	RTPF	RTPF	RTPF	RTPF	RTPF	RTPF
Rows / FPI	2 / 17	2 / 17	2 / 17	3 / 17	2 / 17	2 / 17
Total Face Area (ft²)	17.5	23.0	25.1	31.8	23.5 x 2	25.0 x 2
Condenser Fan / Motor						
Qty / Motor Drive Type	2 / direct	2 / direct	2 / direct	2 / direct	3 / direct	4 / direct
Motor hp / rpm	1/4 / 1100	1/4 / 1100	1/4 / 1100	1/4 / 1100	1/4 / 1100	1/4 / 1100
Fan Diameter (in.)	22	22	22	22	22	22
Nominal Airflow (cfm)	6,000	6,000	6,000	6,000	9,000	12,000
Watts (total)	610	610	610	610	970	1150
Piping Connections						
Qty / Suction (in. ODS)	1 / 1-1/8	1 / 1-1/8	1 / 1-3/8	1 / 1-3/8	1 / 1-3/8	1 / 1-5/8
Qty / Liquid (in. ODS)	1 / 3/8	1 / 1/2	1 / 1/2	1 / 5/8	1 / 5/8	1 / 5/8

NOTE(S):

- a. Approximate system charge with about 25 ft piping of sizes indicated with matched 40RL unit.

38AXD*12-28 Two Circuit Models – Physical Data

UNIT	38AXD(T,U)12	38AXD(T,U)14	38AXD(T,U)16	38AXD(T,U)25	38AXD(T,U)28
NOMINAL CAPACITY (tons)	10	12.5	15	20	25
OPERATING WEIGHT (lb)	516	654	731	978	978
Refrigeration System					
No. Circuits / No. Comp. / Type	2 / 2 / Scroll	2 / 2 / Scroll	2 / 2 / Scroll	2 / 2 / Scroll	2 / 2 / Scroll
Refrigerant Type	Puron Advance™ R-454B	Puron Advance™ R-454B	Puron Advance™ R-454B	Puron Advance™ R-454B	Puron Advance™ R-454B
R-454B Shipping Charge A/B (lb, 60 Hz)	9.0 / 9.0	9.0 / 9.0	9.0 / 9.0	9.0 / 9.0	9.0 / 9.0
System Charge w/ Fan Coil^a (60 Hz)	10.1 / 9.9	15 / 15	19 / 18.5	17.8 / 17.3	19.5 / 23
Metering Device	TXV	TXV	TXV	TXV	TXV
High-press. Trip / Reset (psig)	630 / 505	630 / 505	630 / 505	630 / 505	630 / 505
Low-press. Trip / Reset (psig)	54 / 117	54 / 117	54 / 117	54 / 117	54 / 117
Compressor					
Oil Charge A/B (oz)	42 / 42	42 / 42	58 / 58	85 / 85	121 / 85
Speed (rpm, 60/50 Hz)	3500	3500	3500	3500	3500
Condenser Coil					
Material	Al/Cu	Al/Cu	Al/Cu	Al/Cu	Al/Cu
Coil Type	RTPF	RTPF	RTPF	RTPF	RTPF
Rows / FPI	2 / 17	3 / 17	2 / 17	2 / 17	2 / 17
Total Face Area (ft²)	31.8	31.8	23.5 x 2	25.0 x 2	28.4 / 31.5
Condenser Fan / Motor					
Qty / Motor Drive Type	2 / direct	2 / direct	3 / direct	4 / direct	4 / direct
Motor hp / rpm	1/4 / 1100	1/4 / 1100	1/4 / 1100	1/4 / 1100	1/4 / 1100
Fan Diameter (in.)	22	22	22	22	22
Nominal Airflow (cfm)	6,000	6,000	9,000	12,000	12,000
Watts (total)	610	610	970	1150	1150
Piping Connections					
Qty / Suction (in. ODS)	2 / 1-1/8	2 / 1-3/8	2 / 1-3/8	2 / 1-3/8	2 / 1-3/8
Qty / Liquid (in. ODS)	2 / 3/8	2 / 1/2	2 / 1/2	2 / 1/2	2 / 1/2

NOTE(S):

- a. Approximate system charge with about 25 ft piping of sizes indicated with matched 40RL unit.

Liquid Line Diameter — Condenser Above Evaporator

UNIT M/N	NOMINAL TONNAGE	CIRCUITS		LINEAR LENGTH (ft)	0-25		26-50		51-75		76-100		101-125		126-150		151-175		176-200		
				EQUIV. LINEAR LENGTH (ft)	0-37		38-74		75-112		113-149		150-187		188-224		225-262		263-300		
					Nominal	Nominal	Allowable	Nominal	Allowable	Nominal	Allowable	Nominal	Allowable	Nominal	Allowable	Nominal	Allowable	Nominal	Allowable	Nominal	Allowable
38AXZ*07 40RLAA07	6	1	A Circuit	Liquid Line Dia. (in.)	3/8	3/8	1/2	3/8	1/2	1/2	5/8	1/2	5/8	1/2	5/8	1/2	5/8	1/2	5/8	1/2	5/8
				Max Lift (ft)	25	50	50	75	75	100	100	125	125	150	150	175	175	200	200		
38AXZ*08 40RLAA08	7.5	1	A Circuit	Liquid Line Dia. (in.)	1/2	1/2	5/8	1/2	5/8	1/2	5/8	5/8	3/4	5/8	3/4	5/8	3/4	5/8	3/4	5/8	3/4
				Max Lift (ft)	25	50	50	75	75	100	100	125	125	150	150	175	175	200	200		
38AXZ*12 40RLAA12	10	1	A Circuit	Liquid Line Dia. (in.)	1/2	1/2	5/8	1/2	5/8	1/2	5/8	5/8	3/4	7/8	1-1/8	7/8	1-1/8	7/8	1-1/8	7/8	1-1/8
				Max Lift (ft)	25	50	50	75	75	100	100	125	125	150	150	175	175	200	200		
38AXZ*14 40RLAA14	12.5	1	A Circuit	Liquid Line Dia. (in.)	5/8	5/8	3/4	5/8	3/4	5/8	3/4	5/8	3/4	5/8	3/4	5/8	3/4	5/8	3/4	5/8	3/4
				Max Lift (ft)	25	50	50	75	75	100	100	125	125	150	150	175	175	200	200		
38AXZ*16 40RLAA16	15	1	A Circuit	Liquid Line Dia. (in.)	5/8	5/8	3/4	5/8	3/4	5/8	3/4	5/8	3/4	7/8	1-1/8	7/8	1-1/8	7/8	1-1/8	7/8	1-1/8
				Max Lift (ft)	25	50	50	75	75	100	100	125	125	150	150	175	175	200	200		
38AXZ*25 40RLAA25	20	1	A Circuit	Liquid Line Dia. (in.)	5/8	5/8	3/4	5/8	3/4	5/8	3/4	3/4	7/8	1-1/8	—	1-1/8	—	1-1/8	—	1-1/8	—
				Max Lift (ft)	25	50	50	75	75	100	100	125	125	150	—	175	—	200	—		
38AXD*12 40RLAA12	10	2	A Circuit	Liquid Line Dia. (in.)	3/8	3/8	3/8	3/8	3/8	1/2	5/8	5/8	3/4	5/8	3/4	5/8	3/4	5/8	3/4	5/8	3/4
				Max Lift (ft)	25	50	50	75	75	100	100	125	125	150	150	175	175	200	200		
			B Circuit	Liquid Line Dia. (in.)	3/8	3/8	3/8	3/8	3/8	1/2	5/8	3/4	7/8	3/4	7/8	3/4	7/8	3/4	7/8	3/4	7/8
				Max Lift (ft)	25	50	50	75	75	100	100	125	125	150	150	175	175	200	200		
38AXD*14 40RLAA14	12.5	2	A Circuit	Liquid Line Dia. (in.)	3/8	3/8	3/8	3/8	3/8	1/2	5/8	1/2	5/8	1/2	5/8	1/2	5/8	1/2	5/8	1/2	5/8
				Max Lift (ft)	25	50	50	75	75	100	100	125	125	150	150	175	175	200	200		
			B Circuit	Liquid Line Dia. (in.)	3/8	3/8	3/8	3/8	3/8	3/8	3/8	1/2	5/8	1/2	5/8	1/2	5/8	1/2	5/8	1/2	5/8
				Max Lift (ft)	25	50	50	75	75	100	100	125	125	150	150	175	175	200	200		
38AXD*16 40RLAA16	15	2	A Circuit	Liquid Line Dia. (in.)	3/8	3/8	1/2	3/8	1/2	1/2	5/8	1/2	5/8	1/2	5/8	1/2	5/8	1/2	5/8	1/2	5/8
				Max Lift (ft)	25	50	50	75	75	100	100	125	125	150	150	175	175	200	200		
			B Circuit	Liquid Line Dia. (in.)	3/8	3/8	1/2	3/8	1/2	1/2	5/8	1/2	5/8	5/8	3/4	5/8	3/4	5/8	3/4	5/8	3/4
				Max Lift (ft)	25	50	50	75	75	100	100	125	125	150	150	175	175	200	200		
38AXD*25 40RLAA25	20	2	A Circuit	Liquid Line Dia. (in.)	1/2	1/2	1/2	1/2	1/2	1/2	5/8	5/8	3/4	5/8	3/4	7/8	1-1/8	7/8	1-1/8	7/8	1-1/8
				Max Lift (ft)	25	50	50	75	75	100	100	125	125	150	150	175	175	200	200		
			B Circuit	Liquid Line Dia. (in.)	1/2	1/2	5/8	5/8	3/4	5/8	3/4	3/4	7/8	3/4	7/8	7/8	1-1/8	7/8	1-1/8	7/8	1-1/8
				Max Lift (ft)	25	50	50	75	75	100	100	125	125	150	150	175	175	200	200		
38AXD*28 40RLAA28	25	2	A Circuit	Liquid Line Dia. (in.)	1/2	1/2	1/2	1/2	1/2	1/2	5/8	5/8	3/4	7/8	1-1/8	7/8	1-1/8	7/8	1-1/8	7/8	1-1/8
				Max Lift (ft)	25	50	50	75	75	100	100	125	125	150	150	175	175	200	200		
			B Circuit	Liquid Line Dia. (in.)	1/2	1/2	5/8	1/2	5/8	5/8	3/4	5/8	3/4	7/8	1-1/8	1-1/8	—	1-1/8	—		
				Max Lift (ft)	25	50	50	75	75	100	100	125	125	150	150	175	—	200	—		



Suction Line Diameter — Condenser Above Evaporator^{a,b,c,d}

Physical data (cont)

UNIT M/N	NOMINAL TONNAGE	CIRCUITS	SUCTION RISER TYPE	LINEAR LENGTH (ft)	0-25		26-50		51-75		76-100		101-125		126-150		151-175		176-200					
				EQUIV. LINEAR LENGTH (ft)	0-37		38-74		75-112		113-149		150-187		188-224		225-262		263-300					
					Nominal	Nominal	Allowable	Nominal	Allowable	Nominal	Allowable	Nominal	Allowable	Nominal	Allowable	Nominal	Allowable	Nominal	Allowable	Nominal	Allowable			
38AXZ*07 40RLAA07	6	1	A Circuit	None	Suction Line Dia (S)	7/8	7/8	1-1/8	7/8	1-1/8	7/8	1-1/8	7/8	1-1/8	7/8	1-1/8	7/8	1-1/8	7/8	1-1/8	7/8	1-1/8		
					Capacity Loss	0.2%	0.8%	0.0%	1.4%	0.2%	2.0%	0.4%	2.7%	0.6%	3.3%	0.8%	3.9%	1.0%	4.5%	1.2%				
					Suction Line Dia (S)	7/8	7/8	1-1/8	7/8	1-1/8	7/8	1-1/8	7/8	1-1/8	7/8	1-1/8	7/8	1-1/8	7/8	1-1/8	7/8	1-1/8		
				Speed Riser	Suction Riser Dia (A)	3/4	3/4	7/8	3/4	7/8	3/4	7/8	3/4	7/8	3/4	7/8	3/4	7/8	3/4	7/8	3/4	7/8	3/4	7/8
					Capacity Loss	0.2%	0.8%	0.0%	1.4%	0.2%	2.0%	0.4%	2.7%	0.6%	3.3%	0.8%	3.9%	1.0%	4.5%	1.2%				
					Suction Line Dia (S)	7/8	7/8	1-1/8	7/8	1-1/8	7/8	1-1/8	7/8	1-1/8	7/8	1-1/8	7/8	1-1/8	7/8	1-3/8	7/8	1-3/8		
				Double Suction Riser	Suction Riser Dia (A)	1/2	1/2	3/4	1/2	3/4	1/2	3/4	1/2	3/4	1/2	3/4	1/2	3/4	3/4	7/8	3/4	7/8		
					Suction Riser Dia (B)	3/4	3/4	7/8	3/4	7/8	3/4	7/8	3/4	7/8	3/4	7/8	3/4	7/8	7/8	1-1/8	7/8	1-1/8		
					Capacity Loss	0.8%	2.0%	0.4%	2.7%	0.6%	3.3%	0.8%	3.9%	1.0%	4.5%	1.2%	1.4%	0.1%	1.7%	0.2%				
38AXZ*08 40RLAA08	7.5	1	A Circuit	None	Suction Line Dia (S)	1-1/8	1-1/8	1-3/8	1-1/8	1-3/8	1-1/8	1-3/8	1-1/8	1-3/8	1-1/8	1-3/8	1-1/8	1-3/8	1-1/8	1-3/8	1-1/8	1-3/8		
					Capacity Loss	—	0.2%	—	0.5%	—	0.9%	—	1.2%	0.1%	1.5%	0.2%	1.8%	0.3%	2.1%	0.4%				
					Suction Line Dia (S)	1-1/8	1-1/8	1-3/8	1-1/8	1-3/8	1-1/8	1-3/8	1-1/8	1-3/8	1-1/8	1-3/8	1-1/8	1-3/8	1-1/8	1-3/8	1-1/8	1-3/8		
				Speed Riser	Suction Riser Dia (A)	7/8	7/8	1-1/8	7/8	1-1/8	7/8	1-1/8	7/8	1-1/8	7/8	1-1/8	7/8	1-1/8	7/8	1-1/8	7/8	1-1/8	7/8	1-1/8
					Capacity Loss	—	0.2%	—	0.5%	—	0.9%	—	1.2%	0.1%	1.5%	0.2%	1.8%	0.3%	2.1%	0.4%				
					Suction Line Dia (S)	1-1/8	1-1/8	1-3/8	1-1/8	1-3/8	1-1/8	1-3/8	1-1/8	1-3/8	1-1/8	1-3/8	1-1/8	1-3/8	1-1/8	1-3/8	1-1/8	1-3/8		
				Double Suction Riser	Suction Riser Dia (A)	3/4	3/4	7/8	3/4	7/8	3/4	7/8	3/4	7/8	3/4	7/8	3/4	7/8	3/4	7/8	3/4	7/8		
					Suction Riser Dia (B)	7/8	7/8	1-1/8	7/8	1-1/8	7/8	1-1/8	7/8	1-1/8	7/8	1-1/8	7/8	1-1/8	7/8	1-1/8	7/8	1-1/8		
					Capacity Loss	0.2%	0.8%	—	1.2%	0.1%	1.5%	0.2%	1.8%	0.3%	2.1%	0.4%	2.4%	0.5%	2.7%	0.6%				
38AXZ*12 40RLAA12	10	1	A Circuit	None	Suction Line Dia (S)	1-3/8	1-3/8	1-5/8	1-3/8	1-5/8	1-3/8	1-5/8	1-3/8	1-5/8	1-3/8	1-5/8	1-3/8	1-5/8	1-3/8	1-5/8	1-3/8	1-5/8		
					Capacity Loss	—	—	—	0.1%	—	0.2%	—	0.4%	—	0.6%	0.0%	0.7%	0.1%	0.9%	0.1%				
					Suction Line Dia (S)	1-3/8	1-3/8	1-5/8	1-3/8	1-5/8	1-3/8	1-5/8	1-3/8	1-5/8	1-3/8	1-5/8	1-3/8	1-5/8	1-3/8	1-5/8	1-3/8	1-5/8		
				Speed Riser	Suction Riser Dia (A)	1-1/8	1-1/8	1-3/8	1-1/8	1-3/8	1-1/8	1-3/8	1-1/8	1-3/8	1-1/8	1-3/8	1-1/8	1-3/8	1-1/8	1-3/8	1-1/8	1-3/8		
					Capacity Loss	—	—	—	0.1%	—	0.2%	—	0.4%	—	0.6%	0.0%	0.7%	0.1%	0.9%	0.1%				
					Suction Line Dia (S)	1-3/8	1-3/8	1-5/8	1-3/8	1-5/8	1-3/8	1-5/8	1-3/8	1-5/8	1-3/8	1-5/8	1-3/8	1-5/8	1-3/8	1-5/8	1-3/8	1-5/8		
				Double Suction Riser	Suction Riser Dia (A)	7/8	7/8	7/8	7/8	7/8	7/8	7/8	7/8	7/8	7/8	7/8	7/8	7/8	7/8	7/8	7/8	7/8		
					Suction Riser Dia (B)	1-1/8	1-1/8	1-3/8	1-1/8	1-3/8	1-1/8	1-3/8	1-1/8	1-3/8	1-1/8	1-3/8	1-1/8	1-3/8	1-1/8	1-3/8	1-1/8	1-3/8		
					Capacity Loss	—	0.2%	—	0.4%	—	0.6%	0.0%	0.7%	0.1%	0.9%	0.1%	1.0%	0.2%	1.2%	0.3%				
38AXZ*14 40RLAA14	12.5	1	A Circuit	None	Suction Line Dia (S)	1-5/8	1-5/8	—	1-5/8	—	1-5/8	—	1-5/8	—	1-5/8	—	1-5/8	—	1-5/8	—	1-5/8			
					Capacity Loss	—	—	—	—	—	0.0%	—	0.1%	—	0.2%	—	0.3%	—	0.4%	—				
					Suction Line Dia (S)	1-5/8	1-5/8	—	1-5/8	—	1-5/8	—	1-5/8	—	1-5/8	—	1-5/8	—	1-5/8	—	1-5/8			
				Speed Riser	Suction Riser Dia (A)	1-3/8	1-3/8	—	1-3/8	—	1-3/8	—	1-3/8	—	1-3/8	—	1-3/8	—	1-3/8	—	1-3/8	—		
					Capacity Loss	—	—	—	—	—	0.0%	—	0.1%	—	0.2%	—	0.3%	—	0.4%	—				
					Suction Line Dia (S)	1-5/8	1-5/8	—	1-5/8	—	1-5/8	—	1-5/8	—	1-5/8	—	1-5/8	—	1-5/8	—	1-5/8			
				Double Suction Riser	Suction Riser Dia (A)	7/8	7/8	—	7/8	—	7/8	—	7/8	—	7/8	—	7/8	—	7/8	—	7/8	—		
					Suction Riser Dia (B)	1-3/8	1-3/8	—	1-3/8	—	1-3/8	—	1-3/8	—	1-3/8	—	1-3/8	—	1-3/8	—	1-3/8	—		
					Capacity Loss	—	0.0%	—	0.1%	—	0.2%	—	0.3%	—	0.4%	—	0.5%	—	0.6%	—				
38AXZ*16 40RLAA16	15	1	A Circuit	None	Suction Line Dia. (S)	1-3/8	1-3/8	1-5/8	1-3/8	1-5/8	1-3/8	1-5/8	1-3/8	1-5/8	1-3/8	1-5/8	1-3/8	1-5/8	1-3/8	1-5/8	1-3/8	1-5/8		
					Capacity Loss	—	0.3%	—	0.6%	—	1.0%	0.2%	1.3%	0.3%	1.7%	0.5%	2.0%	0.6%	2.4%	0.8%				
					Suction Line Dia. (S)	1-3/8	1-3/8	1-5/8	1-3/8	1-5/8	1-3/8	1-5/8	1-3/8	1-5/8	1-3/8	1-5/8	1-3/8	1-5/8	1-3/8	1-5/8	1-3/8	1-5/8		
				Speed Riser	Suction Riser Dia. (A)	1-1/8	1-1/8	1-3/8	1-1/8	1-3/8	1-1/8	1-3/8	1-1/8	1-3/8	1-1/8	1-3/8	1-1/8	1-3/8	1-1/8	1-3/8	1-1/8	1-3/8		
					Capacity Loss	—	0.3%	—	0.6%	—	1.0%	0.2%	1.3%	0.3%	1.7%	0.5%	2.0%	0.6%	2.4%	0.8%				
					Suction Line Dia. (S)	1-3/8	1-3/8	1-5/8	1-3/8	1-5/8	1-3/8	1-5/8	1-3/8	1-5/8	1-3/8	1-5/8	1-3/8	1-5/8	1-3/8	1-5/8	1-3/8	1-5/8		
				Double Suction Riser	Suction Riser Dia. (A)	7/8	7/8	7/8	7/8	7/8	7/8	7/8	7/8	7/8	7/8	7/8	7/8	7/8	7/8	7/8	7/8	7/8		
					Suction Riser Dia. (B)	1-1/8	1-1/8	1-3/8	1-1/8	1-3/8	1-1/8	1-3/8	1-1/8	1-3/8	1-1/8	1-3/8	1-1/8	1-3/8	1-1/8	1-3/8	1-1/8	1-3/8		
					Capacity Loss	0.3%	1.0%	0.2%	1.3%	0.3%	1.7%	0.5%	2.0%	0.6%	2.4%	0.8%	2.7%	0.9%	3.1%	1.1%				



Suction Line Diameter — Condenser Above Evaporator^{a,b,c,d} (cont)

Physical data (cont)

UNIT M/N	NOMINAL TONNAGE	CIRCUITS	SUCTION RISER TYPE	LINEAR LENGTH (ft)	0-25	26-50	51-75	76-100	101-125	126-150	151-175	176-200										
				EQUIV. LINEAR LENGTH (ft)	0-37	38-74	75-112	113-149	150-187	188-224	225-262	263-300										
				Nominal	Nominal	Allowable	Nominal	Allowable	Nominal	Allowable	Nominal	Allowable	Nominal	Allowable								
38AXZ*25 40RLAA25	20	1	A Circuit	None	Suction Line Dia. (S)	1-3/8	1-3/8	1-5/8	1-3/8	1-5/8	1-3/8	1-5/8	1-3/8	1-5/8	1-3/8	1-5/8	1-3/8	1-5/8				
					Capacity Loss	—	0.6%	—	1.0%	0.2%	1.5%	0.4%	2.0%	0.6%	2.5%	0.8%	3.0%	1.0%	3.4%	1.2%		
				Speed Riser	Suction Line Dia. (S)	1-3/8	1-3/8	1-5/8	1-3/8	1-5/8	1-3/8	1-5/8	1-3/8	1-5/8	1-3/8	1-5/8	1-3/8	1-5/8	1-3/8	1-5/8	1-3/8	1-5/8
			Suction Riser Dia. (A)	1-1/8	1-1/8	1-3/8	1-1/8	1-3/8	1-1/8	1-3/8	1-1/8	1-3/8	1-1/8	1-3/8	1-1/8	1-3/8	1-1/8	1-3/8	1-1/8	1-3/8		
			Capacity Loss	0.1%	0.6%	—	1.0%	0.2%	1.5%	0.4%	2.0%	0.6%	2.5%	0.8%	3.0%	1.0%	3.4%	1.2%				
			Double Suction Riser	Suction Line Dia. (S)	1-3/8	1-3/8	1-5/8	1-3/8	1-5/8	1-3/8	1-5/8	1-3/8	1-5/8	1-3/8	1-5/8	1-3/8	1-5/8	1-3/8	1-5/8	1-3/8	1-5/8	
		Suction Riser Dia. (A)	7/8	7/8	7/8	7/8	7/8	7/8	7/8	7/8	7/8	7/8	7/8	7/8	7/8	7/8	7/8	7/8	7/8			
		Suction Riser Dia. (B)	1-1/8	1-1/8	1-3/8	1-1/8	1-3/8	1-1/8	1-3/8	1-1/8	1-3/8	1-1/8	1-3/8	1-1/8	1-3/8	1-1/8	1-3/8	1-1/8	1-3/8			
		Capacity Loss	0.6%	1.5%	0.4%	2.0%	0.6%	2.5%	0.8%	3.0%	1.0%	3.4%	1.2%	3.9%	1.4%	4.4%	1.6%					
		38AXD*12 40RLAA12	10	2	A Circuit	None	Suction Line Dia (S)	7/8	7/8	1-1/8	7/8	1-1/8	7/8	1-1/8	7/8	1-1/8	7/8	1-1/8	7/8	1-1/8	7/8	1-1/8
							Capacity Loss	0.1%	0.6%	—	1.1%	0.1%	1.6%	0.3%	2.1%	0.5%	2.6%	0.7%	3.1%	0.8%	3.6%	1.0%
						Speed Riser	Suction Line Dia (S)	7/8	7/8	1-1/8	7/8	1-1/8	7/8	1-1/8	7/8	1-1/8	7/8	1-1/8	7/8	1-1/8	7/8	1-1/8
Suction Riser Dia (A)	3/4				3/4	7/8	3/4	7/8	3/4	7/8	3/4	7/8	3/4	7/8	3/4	7/8	3/4	7/8	3/4	7/8		
Capacity Loss	0.1%				0.6%	—	1.1%	0.1%	1.6%	0.3%	2.1%	0.5%	2.6%	0.7%	3.1%	0.8%	3.6%	1.0%				
Double Suction Riser	Suction Line Dia (S)				7/8	7/8	1-1/8	7/8	1-1/8	7/8	1-1/8	7/8	1-1/8	7/8	1-1/8	7/8	1-1/8	7/8	1-1/8	7/8	1-1/8	
Suction Riser Dia (A)	1/2			1/2	3/4	1/2	3/4	1/2	3/4	1/2	3/4	1/2	3/4	1/2	3/4	1/2	3/4	1/2	3/4			
Suction Riser Dia (B)	3/4			3/4	7/8	3/4	7/8	3/4	7/8	3/4	7/8	3/4	7/8	3/4	7/8	3/4	7/8	3/4	7/8			
Capacity Loss	0.6%			1.6%	0.3%	2.1%	0.5%	2.6%	0.7%	3.1%	0.8%	3.6%	1.0%	4.1%	1.2%	4.4%	1.4%	4.9%				
B Circuit	None			Suction Line Dia (S)	7/8	7/8	1-1/8	7/8	1-1/8	7/8	1-1/8	7/8	1-1/8	7/8	1-1/8	7/8	1-1/8	7/8	1-1/8	7/8	1-1/8	
				Capacity Loss	0.1%	0.5%	—	1.0%	0.1%	1.4%	0.3%	1.9%	0.4%	2.3%	0.6%	2.8%	0.7%	3.3%	0.9%			
	Speed Riser			Suction Line Dia (S)	7/8	7/8	1-1/8	7/8	1-1/8	7/8	1-1/8	7/8	1-1/8	7/8	1-1/8	7/8	1-1/8	7/8	1-1/8	7/8	1-1/8	
	Suction Riser Dia (A)	3/4	3/4	7/8	3/4	7/8	3/4	7/8	3/4	7/8	3/4	7/8	3/4	7/8	3/4	7/8	3/4	7/8				
	Capacity Loss	0.1%	0.5%	—	1.0%	0.1%	1.4%	0.3%	1.9%	0.4%	2.3%	0.6%	2.8%	0.7%	3.3%	0.9%						
	Double Suction Riser	Suction Line Dia (S)	7/8	7/8	1-1/8	7/8	1-1/8	7/8	1-1/8	7/8	1-1/8	7/8	1-1/8	7/8	1-1/8	7/8	1-1/8	7/8	1-1/8			
Suction Riser Dia (A)	1/2	1/2	3/4	1/2	3/4	1/2	3/4	1/2	3/4	1/2	3/4	1/2	3/4	1/2	3/4	1/2	3/4					
Suction Riser Dia (B)	3/4	3/4	7/8	3/4	7/8	3/4	7/8	3/4	7/8	3/4	7/8	3/4	7/8	3/4	7/8	3/4	7/8					
Capacity Loss	0.5%	1.4%	0.2%	1.9%	0.4%	2.3%	0.6%	2.8%	0.7%	3.2%	0.9%	3.7%	1.1%	4.2%	1.2%							
38AXD*14 40RLAA14	12.5	2	A Circuit	None	Suction Line Dia (S)	1-3/8	1-3/8	—	1-3/8	—	1-3/8	—	1-3/8	—	1-3/8	—	1-3/8	—	1-3/8	—		
					Capacity Loss	—	—	—	—	—	—	—	—	—	—	—	—	—	—	—	—	—
				Speed Riser	Suction Line Dia (S)	1-3/8	1-3/8	—	1-3/8	—	1-3/8	—	1-3/8	—	1-3/8	—	1-3/8	—	1-3/8	—	1-3/8	—
			Suction Riser Dia (A)	1-1/8	1-1/8	—	1-1/8	—	1-1/8	—	1-1/8	—	1-1/8	—	1-1/8	—	1-1/8	—	1-1/8	—		
			Capacity Loss	—	—	—	—	—	—	—	—	—	—	—	—	—	—	—	—	—		
			Double Suction Riser	Suction Line Dia (S)	1-3/8	1-3/8	1-5/8	1-3/8	1-5/8	1-3/8	1-5/8	1-3/8	1-5/8	1-3/8	1-5/8	1-3/8	1-5/8	1-3/8	1-5/8	1-3/8	1-5/8	
		Suction Riser Dia (A)	7/8	7/8	7/8	7/8	7/8	7/8	7/8	7/8	7/8	7/8	7/8	7/8	7/8	7/8	7/8	7/8	7/8			
		Suction Riser Dia (B)	1-1/8	1-1/8	1-3/8	1-1/8	1-3/8	1-1/8	1-3/8	1-1/8	1-3/8	1-1/8	1-3/8	1-1/8	1-3/8	1-1/8	1-3/8	1-1/8	1-3/8			
		Capacity Loss	—	—	—	—	—	—	—	—	—	—	—	—	—	—	—	—	—			
		B Circuit	None	Suction Line Dia (S)	1-3/8	1-3/8	—	1-3/8	—	1-3/8	—	1-3/8	—	1-3/8	—	1-3/8	—	1-3/8	—	1-3/8	—	
				Capacity Loss	—	—	—	—	—	—	—	—	—	—	—	—	—	—	—	—	—	
			Speed Riser	Suction Line Dia (S)	1-3/8	1-3/8	—	1-3/8	—	1-3/8	—	1-3/8	—	1-3/8	—	1-3/8	—	1-3/8	—	1-3/8	—	
Suction Riser Dia (A)	1-1/8		1-1/8	—	1-1/8	—	1-1/8	—	1-1/8	—	1-1/8	—	1-1/8	—	1-1/8	—	1-1/8	—				
Capacity Loss	—		—	—	—	—	—	—	—	—	—	—	—	—	—	—	—	—				
Double Suction Riser	Suction Line Dia (S)		1-3/8	1-3/8	1-5/8	1-3/8	1-5/8	1-3/8	1-5/8	1-3/8	1-5/8	1-3/8	1-5/8	1-3/8	1-5/8	1-3/8	1-5/8	1-3/8	1-5/8			
Suction Riser Dia (A)	7/8	7/8	7/8	7/8	7/8	7/8	7/8	7/8	7/8	7/8	7/8	7/8	7/8	7/8	7/8	7/8	7/8					
Suction Riser Dia (B)	1-1/8	1-1/8	1-3/8	1-1/8	1-3/8	1-1/8	1-3/8	1-1/8	1-3/8	1-1/8	1-3/8	1-1/8	1-3/8	1-1/8	1-3/8	1-1/8	1-3/8					
Capacity Loss	—	—	—	—	—	—	—	—	—	—	—	—	—	—	—	—	—					



Suction Line Diameter — Condenser Above Evaporator^{a,b,c,d} (cont)

UNIT M/N	NOMINAL TONNAGE	CIRCUITS	SUCTION RISER TYPE	LINEAR LENGTH (ft)	0-25	26-50	51-75	76-100	101-125	126-150	151-175	176-200								
				EQUIV. LINEAR LENGTH (ft)	0-37	38-74	75-112	113-149	150-187	188-224	225-262	263-300								
				Nominal	Nominal	Allowable	Nominal	Allowable	Nominal	Allowable	Nominal	Allowable	Nominal	Allowable						
38AXD*16 40RLAA16	15	A Circuit	None	Suction Line Dia. (S)	1-3/8	1-3/8	—	1-3/8	—	1-3/8	—	1-3/8	—	1-3/8	—	1-3/8	—			
				Capacity Loss	—	—	—	—	—	—	—	0.1%	—	0.2%	—	0.3%	—	0.4%	—	
			Speed Riser	Suction Line Dia. (S)	1-3/8	1-3/8	—	1-3/8	—	1-3/8	—	1-3/8	—	1-3/8	—	1-3/8	—	1-3/8	—	
				Suction Riser Dia. (A)	1-1/8	1-1/8	—	1-1/8	—	1-1/8	—	1-1/8	—	1-1/8	—	1-1/8	—	1-1/8	—	
			Double Suction Riser	Suction Line Dia. (S)	1-3/8	1-3/8	1-5/8	1-3/8	1-5/8	1-3/8	1-5/8	1-3/8	1-5/8	1-3/8	1-5/8	1-3/8	1-5/8	1-3/8	1-5/8	
				Suction Riser Dia. (A)	7/8	7/8	7/8	7/8	7/8	7/8	7/8	7/8	7/8	7/8	7/8	7/8	7/8	7/8	7/8	
		Suction Riser Dia. (B)		1-1/8	1-1/8	1-3/8	1-1/8	1-3/8	1-1/8	1-3/8	1-1/8	1-3/8	1-1/8	1-3/8	1-1/8	1-3/8	1-1/8	1-3/8		
		Capacity Loss		—	—	—	0.1%	—	0.2%	—	0.3%	—	0.4%	—	0.5%	—	0.6%	0.0%		
		B Circuit	None	Suction Line Dia. (S)	1-3/8	1-3/8	—	1-3/8	—	1-3/8	—	1-3/8	—	1-3/8	—	1-3/8	—	1-3/8	—	
				Capacity Loss	—	—	—	—	—	0.0%	—	0.1%	—	0.2%	—	0.3%	—	0.4%	—	
			Speed Riser	Suction Line Dia. (S)	1-3/8	1-3/8	—	1-3/8	—	1-3/8	—	1-3/8	—	1-3/8	—	1-3/8	—	1-3/8	—	
				Suction Riser Dia. (A)	1-1/8	1-1/8	—	1-1/8	—	1-1/8	—	1-1/8	—	1-1/8	—	1-1/8	—	1-1/8	—	
	Double Suction Riser		Suction Line Dia. (S)	1-3/8	1-3/8	1-5/8	1-3/8	1-5/8	1-3/8	1-5/8	1-3/8	1-5/8	1-3/8	1-5/8	1-3/8	1-5/8	1-3/8	1-5/8		
			Suction Riser Dia. (A)	7/8	7/8	7/8	7/8	7/8	7/8	7/8	7/8	7/8	7/8	7/8	7/8	7/8	7/8	7/8		
	38AXD*25 40RLAA25	20	A Circuit	None	Suction Line Dia. (S)	1-1/8	1-1/8	1-3/8	1-1/8	1-3/8	1-1/8	1-3/8	1-1/8	1-3/8	1-1/8	1-3/8	1-1/8	1-3/8		
					Capacity Loss	0.1%	0.6%	—	1.1%	0.1%	1.6%	0.3%	2.1%	0.4%	2.6%	0.6%	3.2%	0.8%	3.7%	0.9%
				Speed Riser	Suction Line Dia. (S)	1-1/8	1-1/8	1-3/8	1-1/8	1-3/8	1-1/8	1-3/8	1-1/8	1-3/8	1-1/8	1-3/8	1-1/8	1-3/8	1-1/8	1-3/8
					Suction Riser Dia. (A)	7/8	7/8	1-1/8	7/8	1-1/8	7/8	1-1/8	7/8	1-1/8	7/8	1-1/8	7/8	1-1/8	7/8	1-1/8
				Double Suction Riser	Suction Line Dia. (S)	1-1/8	1-1/8	1-3/8	1-1/8	1-3/8	1-1/8	1-3/8	1-1/8	1-3/8	1-1/8	1-3/8	1-1/8	1-3/8	1-1/8	1-3/8
					Suction Riser Dia. (A)	3/4	3/4	7/8	3/4	7/8	3/4	7/8	3/4	7/8	3/4	7/8	3/4	7/8	3/4	7/8
			Suction Riser Dia. (B)		7/8	7/8	1-1/8	7/8	1-1/8	7/8	1-1/8	7/8	1-1/8	7/8	1-1/8	7/8	1-1/8	7/8		
			Capacity Loss		0.6%	1.6%	0.3%	2.1%	0.4%	2.6%	0.6%	3.2%	0.8%	3.7%	0.9%	4.2%	1.1%	1.3%	0.3%	
			B Circuit	None	Suction Line Dia. (S)	1-1/8	1-1/8	1-3/8	1-1/8	1-3/8	1-1/8	1-3/8	1-1/8	1-3/8	1-1/8	1-3/8	1-1/8	1-3/8	1-1/8	1-3/8
					Capacity Loss	0.1%	0.6%	—	1.1%	0.1%	1.6%	0.3%	2.1%	0.4%	2.6%	0.6%	3.1%	0.8%	3.6%	0.9%
Speed Riser				Suction Line Dia. (S)	1-1/8	1-1/8	1-3/8	1-1/8	1-3/8	1-1/8	1-3/8	1-1/8	1-3/8	1-1/8	1-3/8	1-1/8	1-3/8	1-1/8	1-3/8	
				Suction Riser Dia. (A)	7/8	7/8	1-1/8	7/8	1-1/8	7/8	1-1/8	7/8	1-1/8	7/8	1-1/8	7/8	1-1/8	7/8	1-1/8	
Double Suction Riser		Suction Line Dia. (S)		1-1/8	1-1/8	1-3/8	1-1/8	1-3/8	1-1/8	1-3/8	1-1/8	1-3/8	1-1/8	1-3/8	1-1/8	1-3/8	1-1/8	1-3/8		
		Suction Riser Dia. (A)		3/4	3/4	7/8	3/4	7/8	3/4	7/8	3/4	7/8	3/4	7/8	3/4	7/8	3/4	7/8		
		Suction Riser Dia. (B)	7/8	7/8	1-1/8	7/8	1-1/8	7/8	1-1/8	7/8	1-1/8	7/8	1-1/8	7/8	1-1/8	7/8	1-1/8			
		Capacity Loss	0.6%	1.6%	0.3%	2.1%	0.4%	2.6%	0.6%	3.1%	0.8%	3.6%	0.9%	4.1%	1.1%	1.3%	0.3%			

Physical data (cont)



Suction Line Diameter — Condenser Above Evaporator^{a,b,c,d} (cont)

UNIT M/N	NOMINAL TONNAGE	CIRCUITS	SUCTION RISER TYPE	LINEAR LENGTH (ft)	0-25	26-50		51-75		76-100		101-125		126-150		151-175		176-200					
				EQUIV. LINEAR LENGTH (ft)	0-37	38-74		75-112		113-149		150-187		188-224		225-262		263-300					
				Nominal	Nominal	Allowable	Nominal	Allowable	Nominal	Allowable	Nominal	Allowable	Nominal	Allowable	Nominal	Allowable	Nominal	Allowable	Nominal	Allowable			
38AXD*28 40RLAA28	25	A Circuit	None	Suction Line Dia. (S)	1-3/8	1-3/8	1-5/8	1-3/8	1-5/8	1-3/8	1-5/8	1-3/8	1-5/8	1-3/8	1-5/8	1-3/8	1-5/8	1-3/8	1-5/8	1-3/8	1-5/8		
				Capacity Loss	—	—	—	0.2%	—	0.4%	—	0.6%	—	0.8%	0.1%	1.0%	0.2%	1.2%	0.3%				
			Speed Riser	Suction Line Dia. (S)	1-3/8	1-3/8	1-5/8	1-3/8	1-5/8	1-3/8	1-5/8	1-3/8	1-5/8	1-3/8	1-5/8	1-3/8	1-5/8	1-3/8	1-5/8	1-3/8	1-5/8	1-3/8	1-5/8
				Suction Riser Dia. (A)	1-1/8	1-1/8	1-3/8	1-1/8	1-3/8	1-1/8	1-3/8	1-1/8	1-3/8	1-1/8	1-3/8	1-1/8	1-3/8	1-1/8	1-3/8	1-1/8	1-3/8	1-1/8	1-3/8
			Double Suction Riser	Suction Line Dia. (S)	1-3/8	1-3/8	1-5/8	1-3/8	1-5/8	1-3/8	1-5/8	1-3/8	1-5/8	1-3/8	1-5/8	1-3/8	1-5/8	1-3/8	1-5/8	1-3/8	1-5/8	1-3/8	1-5/8
				Suction Riser Dia. (A)	7/8	7/8	7/8	7/8	7/8	7/8	7/8	7/8	7/8	7/8	7/8	7/8	7/8	7/8	7/8	7/8	7/8	7/8	7/8
			None	Suction Line Dia. (S)	1-3/8	1-3/8	1-5/8	1-3/8	1-5/8	1-3/8	1-5/8	1-3/8	1-5/8	1-3/8	1-5/8	1-3/8	1-5/8	1-3/8	1-5/8	1-3/8	1-5/8	1-3/8	1-5/8
				Capacity Loss	—	0.4%	—	0.6%	—	0.8%	0.1%	1.0%	0.2%	1.2%	0.3%	1.4%	0.4%	1.6%	0.4%	1.6%	0.4%	1.6%	0.4%
			Speed Riser	Suction Line Dia. (S)	1-3/8	1-3/8	1-5/8	1-3/8	1-5/8	1-3/8	1-5/8	1-3/8	1-5/8	1-3/8	1-5/8	1-3/8	1-5/8	1-3/8	1-5/8	1-3/8	1-5/8	1-3/8	1-5/8
				Suction Riser Dia. (A)	1-1/8	1-1/8	1-3/8	1-1/8	1-3/8	1-1/8	1-3/8	1-1/8	1-3/8	1-1/8	1-3/8	1-1/8	1-3/8	1-1/8	1-3/8	1-1/8	1-3/8	1-1/8	1-3/8
			Double Suction Riser	Suction Line Dia. (S)	1-3/8	1-3/8	1-5/8	1-3/8	1-5/8	1-3/8	1-5/8	1-3/8	1-5/8	1-3/8	1-5/8	1-3/8	1-5/8	1-3/8	1-5/8	1-3/8	1-5/8	1-3/8	1-5/8
				Suction Riser Dia. (A)	7/8	7/8	7/8	7/8	7/8	7/8	7/8	7/8	7/8	7/8	7/8	7/8	7/8	7/8	7/8	7/8	7/8	7/8	7/8
		None	Suction Line Dia. (S)	1-3/8	1-3/8	1-5/8	1-3/8	1-5/8	1-3/8	1-5/8	1-3/8	1-5/8	1-3/8	1-5/8	1-3/8	1-5/8	1-3/8	1-5/8	1-3/8	1-5/8	1-3/8	1-5/8	
			Capacity Loss	0.1%	0.6%	—	0.9%	0.1%	1.1%	0.2%	1.4%	0.4%	1.6%	0.5%	1.9%	0.6%	2.2%	0.7%					

NOTE(S):

- a. Pipe diameters are in inches; lengths are in feet.
- b. A continuous rise of 0-10ft; no riser required.
A continuous rise of 11-30ft; speed riser required.
A continuous rise of 31-75ft; double riser required.
A continuous rise of more than 75ft is not recommended.
- c. For Speed Riser, Tube S is the horizontal line size, and Tube A is the reduced diameter riser size.
See installation manual for further details.
- d. For Double Riser, Tube S is the horizontal line size, Tube A is the reduced diameter riser size without bottom trap, and Tube B is the parallel riser size with bottom oil trap.
See installation manual for further details.



Liquid Line Diameter — Condenser Below Evaporator

UNIT M/N	NOMINAL TONNAGE	CIRCUITS		LINEAR LENGTH (ft)	0-25		26-50		51-75		76-100		101-125		126-150		151-175		176-200	
				EQUIV.LINEAR LENGTH (ft)	0-37		38-74		75-112		113-149		150-187		188-224		225-262		263-300	
					Nominal	Nominal	Allowable	Nominal	Allowable	Nominal	Allowable	Nominal	Allowable	Nominal	Allowable	Nominal	Allowable	Nominal	Allowable	Nominal
38AXZ*07 40RLAA07	6	1	A Circuit	Liquid Line Dia (in.)	3/8	3/8	1/2	3/8	1/2	3/8	1/2	5/8	3/4	5/8	3/4	3/4	7/8	3/4	7/8	
				Max Lift (ft)	79	69	76	59	69	50	63	77	83	75	82	81	85	81	85	
38AXZ*08 40RLAA08	7.5	1	A Circuit	Liquid Line Dia (in.)	1/2	1/2	5/8	1/2	5/8	1/2	5/8	5/8	3/4	5/8	3/4	5/8	3/4	5/8	3/4	
				Max Lift (ft)	67	65	69	62	68	59	67	66	68	65	67	64	67	64	67	
38AXZ*12 40RLAA12	10	1	A Circuit	Liquid Line Dia (in.)	1/2	1/2	5/8	1/2	5/8	1/2	5/8	1/2	5/8	5/8	3/4	5/8	3/4	5/8	3/4	
				Max Lift (ft)	84	79	86	74	85	69	83	63	82	81	84	79	83	78	83	
38AXZ*14 40RLAA14	12.5	1	A Circuit	Liquid Line Dia (in.)	5/8	5/8	3/4	5/8	3/4	5/8	3/4	5/8	3/4	5/8	3/4	5/8	3/4	5/8	3/4	
				Max Lift (ft)	100	97	99	95	98	93	97	91	96	89	95	87	93	84	92	
38AXZ*16 40RLAA16	15	1	A Circuit	Liquid Line Dia. (in.)	5/8	5/8	3/4	5/8	3/4	5/8	3/4	5/8	3/4	7/8	1-1/8	7/8	1-1/8	7/8	1-1/8	
				Max Lift (ft)	81	78	81	75	79	72	78	69	76	81	83	80	83	79	83	
38AXZ*25 40RLAA25	20	1	A Circuit	Liquid Line Dia (in.)	5/8	5/8	3/4	5/8	3/4	5/8	3/4	3/4	7/8	1-1/8	—	1-1/8	—	1-1/8	—	
				Max Lift (ft)	74	70	74	65	72	61	69	67	75	77	—	77	—	77	—	
38AXD*12 40RLAA12	10	2	A Circuit	Liquid Line Dia (in.)	3/8	3/8	3/8	3/8	3/8	1/2	5/8	5/8	3/4	5/8	3/4	5/8	3/4	5/8	3/4	
				Max Lift (ft)	59	51	51	42	42	63	66	66	67	65	66	65	66	65	66	
			B Circuit	Liquid Line Dia (in.)	3/8	3/8	3/8	3/8	3/8	1/2	5/8	3/4	7/8	3/4	7/8	3/4	7/8	3/4	7/8	3/4
				Max Lift (ft)	59	48	48	40	40	59	62	63	63	62	63	62	63	62	63	
38AXD*14 40RLAA14	12.5	2	A Circuit	Liquid Line Dia (in.)	3/8	3/8	3/8	3/8	3/8	1/2	5/8	1/2	5/8	1/2	5/8	1/2	5/8	1/2	5/8	
				Max Lift (ft)	83	71	71	59	59	87	92	85	92	83	91	82	90	80	90	
			B Circuit	Liquid Line Dia (in.)	3/8	3/8	3/8	3/8	3/8	3/8	3/8	1/2	5/8	1/2	5/8	1/2	5/8	1/2	5/8	1/2
				Max Lift (ft)	83	76	76	64	64	52	52	90	96	88	96	86	95	84	95	
38AXD*16 40RLAA16	15	2	A Circuit	Liquid Line Dia. (in.)	3/8	3/8	1/2	3/8	1/2	1/2	5/8	1/2	5/8	1/2	5/8	1/2	5/8	1/2	5/8	
				Max Lift (ft)	83	64	95	46	92	89	97	85	97	82	96	79	95	76	94	
			B Circuit	Liquid Line Dia (in.)	3/8	3/8	1/2	3/8	1/2	1/2	5/8	1/2	5/8	1/2	5/8	3/4	5/8	3/4	5/8	3/4
				Max Lift (ft)	83	56	86	38	83	80	89	77	88	87	89	86	89	85	88	
38AXD*25 40RLAA25	20	2	A Circuit	Liquid Line Dia (in.)	1/2	1/2	1/2	1/2	1/2	1/2	5/8	5/8	3/4	5/8	3/4	7/8	1-1/8	7/8	1-1/8	
				Max Lift (ft)	71	65	65	60	60	54	70	68	72	67	71	74	75	73	75	
			B Circuit	Liquid Line Dia (in.)	1/2	1/2	5/8	5/8	3/4	5/8	3/4	3/4	7/8	3/4	7/8	7/8	1-1/8	7/8	1-1/8	
				Max Lift (ft)	71	40	48	46	48	45	47	46	49	45	48	48	50	48	50	
38AXD*28 40RLAA28	25	2	A Circuit	Liquid Line Dia (in.)	1/2	1/2	1/2	1/2	1/2	1/2	5/8	5/8	3/4	7/8	1-1/8	7/8	1-1/8	7/8	1-1/8	
				Max Lift (ft)	71	65	65	58	58	52	71	69	73	76	77	75	77	75	77	
			B Circuit	Liquid Line Dia (in.)	1/2	1/2	5/8	1/2	5/8	5/8	3/4	5/8	3/4	7/8	1-1/8	1-1/8	—	1-1/8	—	
				Max Lift (ft)	71	61	73	52	71	68	73	66	71	75	77	77	—	76	—	

Physical data (cont)



Suction Line Diameter — Condenser Level or Below Evaporator

UNIT M/N	NOMINAL TONNAGE	CIRCUITS		LINEAR LENGTH (ft)	0-25		26-50		51-75		76-100		101-125		126-150		151-175		176-200			
				EQUIV.LINEAR LENGTH (ft)	0-37		38-74		75-112		113-149		150-187		188-224		225-262		263-300			
					Nominal	Nominal	Allowable	Nominal	Allowable	Nominal	Allowable	Nominal	Allowable	Nominal	Allowable	Nominal	Allowable	Nominal	Allowable	Nominal	Allowable	
38AXZ*07 40RLAA07	6	1	A Circuit	Suction Line Dia (S) (in.)	7/8	7/8	1-1/8	7/8	1-1/8	7/8	1-1/8	7/8	1-1/8	7/8	1-1/8	7/8	1-1/8	7/8	1-1/8	7/8	1-1/8	
				Capacity Loss	—	0.81%	0.01%	1.43%	0.22%	2.03%	0.42%	2.65%	0.63%	3.25%	0.83%	3.87%	1.04%	4.49%	1.24%			
38AXZ*08 40RLAA08	7.5	1	A Circuit	Suction Line Dia (S) (in.)	1-1/8	1-1/8	1-3/8	1-1/8	1-3/8	1-1/8	1-3/8	1-1/8	1-3/8	1-1/8	1-3/8	1-1/8	1-3/8	1-1/8	1-3/8	1-1/8	1-3/8	
				Capacity Loss	—	0.23%	—	0.55%	—	0.86%	—	1.17%	0.09%	1.48%	0.18%	1.80%	0.28%	2.12%	0.38%			
38AXZ*12 40RLAA12	10	1	A Circuit	Suction Line Dia (S) (in.)	1-3/8	1-3/8	1-5/8	1-3/8	1-5/8	1-3/8	1-5/8	1-3/8	1-5/8	1-3/8	1-5/8	1-3/8	1-5/8	1-3/8	1-5/8	1-3/8	1-5/8	
				Capacity Loss	—	—	—	0.08%	—	0.24%	—	0.40%	—	0.55%	0.00%	0.71%	0.07%	0.87%	0.14%			
38AXZ*14 40RLAA14	12.5	1	A Circuit	Suction Line Dia (S) (in.)	1-5/8	1-5/8	—	1-5/8	—	1-5/8	—	1-5/8	—	1-5/8	—	1-5/8	—	1-5/8	—	1-5/8	—	
				Capacity Loss	—	—	—	—	—	—	—	—	0.11%	—	0.20%	—	0.30%	—	0.41%	—		
38AXZ*16 40RLAA16	15	1	A Circuit	Suction Line Dia (S) (in.)	1-3/8	1-3/8	1-5/8	1-3/8	1-5/8	1-3/8	1-5/8	1-3/8	1-5/8	1-3/8	1-5/8	1-3/8	1-5/8	1-3/8	1-5/8	1-3/8	1-5/8	
				Capacity Loss	—	0.3%	—	0.6%	—	1.0%	0.2%	1.3%	0.3%	1.7%	0.5%	2.0%	0.6%	2.4%	0.8%			
38AXZ*25 40RLAA25	20	1	A Circuit	Suction Line Dia (S) (in.)	1-3/8	1-3/8	1-5/8	1-3/8	1-5/8	1-3/8	1-5/8	1-3/8	1-5/8	1-3/8	1-5/8	1-3/8	1-5/8	1-3/8	1-5/8	1-3/8	1-5/8	
				Capacity Loss	—	0.6%	—	1.0%	0.2%	1.5%	0.4%	2.0%	0.6%	2.5%	0.8%	3.0%	1.0%	3.4%	1.2%			
38AXD*12 40RLAA12	10	2	A Circuit	Suction Line Dia (S) (in.)	7/8	7/8	1-1/8	7/8	1-1/8	7/8	1-1/8	7/8	1-1/8	7/8	1-1/8	7/8	1-1/8	7/8	1-1/8	7/8	1-1/8	
				Capacity Loss	—	0.60%	—	1.11%	0.13%	1.60%	0.30%	2.11%	0.48%	2.61%	0.65%	3.11%	0.83%	3.62%	1.00%			
38AXD*14 40RLAA14	12.5	2	B Circuit	Suction Line Dia (S) (in.)	7/8	7/8	1-1/8	7/8	1-1/8	7/8	1-1/8	7/8	1-1/8	7/8	1-1/8	7/8	1-1/8	7/8	1-1/8	7/8	1-1/8	
				Capacity Loss	—	0.51%	—	0.97%	0.09%	1.42%	0.25%	1.88%	0.41%	2.33%	0.57%	2.79%	0.74%	3.25%	0.90%			
38AXD*14 40RLAA14	12.5	2	A Circuit	Suction Line Dia (S) (in.)	1-3/8	1-3/8	—	1-3/8	—	1-3/8	—	1-3/8	—	1-3/8	—	1-3/8	—	1-3/8	—	1-3/8	—	
				Capacity Loss	—	—	—	—	—	—	—	—	—	—	—	—	—	—	0.06%	—	0.13%	—
38AXD*16 40RLAA16	15	2	B Circuit	Suction Line Dia (S) (in.)	1-3/8	1-3/8	—	1-3/8	—	1-3/8	—	1-3/8	—	1-3/8	—	1-3/8	—	1-3/8	—	1-3/8	—	
				Capacity Loss	—	—	—	—	—	—	—	—	—	—	—	—	—	—	0.06%	—	0.13%	—
38AXD*16 40RLAA16	15	2	A Circuit	Suction Line Dia (S) (in.)	1-3/8	1-3/8	—	1-3/8	—	1-3/8	—	1-3/8	—	1-3/8	—	1-3/8	—	1-3/8	—	1-3/8	—	
				Capacity Loss	—	—	—	—	—	—	—	—	—	—	—	—	—	—	0.1%	—	0.2%	—
38AXD*25 40RLAA25	20	2	B Circuit	Suction Line Dia (S) (in.)	1-3/8	1-3/8	—	1-3/8	—	1-3/8	—	1-3/8	—	1-3/8	—	1-3/8	—	1-3/8	—	1-3/8	—	
				Capacity Loss	—	—	—	—	—	—	—	—	—	—	—	—	—	—	—	—	—	—
38AXD*25 40RLAA25	20	2	A Circuit	Suction Line Dia (S) (in.)	1-1/8	1-1/8	1-3/8	1-1/8	1-3/8	1-1/8	1-3/8	1-1/8	1-3/8	1-1/8	1-3/8	1-1/8	1-3/8	1-1/8	1-3/8	1-1/8	1-3/8	
				Capacity Loss	0.1%	0.6%	—	1.1%	0.1%	1.6%	0.3%	2.1%	0.4%	2.6%	0.6%	3.2%	0.8%	3.7%	0.9%			
38AXD*25 40RLAA25	20	2	B Circuit	Suction Line Dia (S) (in.)	1-1/8	1-1/8	1-3/8	1-1/8	1-3/8	1-1/8	1-3/8	1-1/8	1-3/8	1-1/8	1-3/8	1-1/8	1-3/8	1-1/8	1-3/8	1-1/8	1-3/8	
				Capacity Loss	0.1%	0.6%	—	1.1%	0.1%	1.6%	0.3%	2.1%	0.4%	2.6%	0.6%	3.1%	0.8%	3.6%	0.9%			
38AXD*28 40RLAA28	25	2	A Circuit	Suction Line Dia (S) (in.)	1-3/8	1-3/8	1-5/8	1-3/8	1-5/8	1-3/8	1-5/8	1-3/8	1-5/8	1-3/8	1-5/8	1-3/8	1-5/8	1-3/8	1-5/8	1-3/8	1-5/8	
				Capacity Loss	—	—	—	0.2%	—	0.4%	—	0.6%	—	0.8%	—	1.0%	—	1.2%	—	1.4%	—	1.6%
38AXD*28 40RLAA28	25	2	B Circuit	Suction Line Dia (S) (in.)	1-3/8	1-3/8	1-5/8	1-3/8	1-5/8	1-3/8	1-5/8	1-3/8	1-5/8	1-3/8	1-5/8	1-3/8	1-5/8	1-3/8	1-5/8	1-3/8	1-5/8	
				Capacity Loss	—	0.1%	—	0.4%	—	0.6%	—	0.9%	0.1%	1.1%	0.2%	1.4%	0.4%	1.6%	0.5%			

LEGEND FOR TABLES

Max Lift — Maximum liquid lift (Indoor unit ABOVE outdoor unit only), at maximum permitted pressure drop.



38AXZ 07-14, 38AXD 12-14 Base Unit Dimensions

CG CENTER OF GRAVITY
 DIRECTION OF AIR FLOW
 DIMENSIONS IN () ARE IN MM



THIS DOCUMENT IS THE PROPERTY OF CARRIER CORPORATION AND IS DELIVERED UPON THE EXPRESS CONDITION THAT THE CONTENTS WILL NOT BE DISCLOSED OR USED WITHOUT CARRIER CORPORATION'S WRITTEN CONSENT.

SUBMISSION OF THESE DRAWINGS OR DOCUMENTS DOES NOT CONSTITUTE PART PERFORMANCE OR ACCEPTANCE OF CONTRACT.

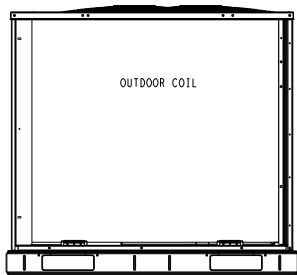

REAR VIEW

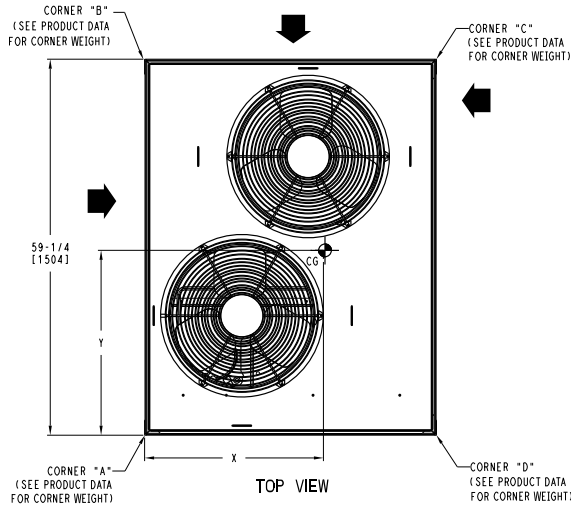

TOP VIEW

SERVICE VALVE CONNECTIONS				
UNIT	SUCTION	LIQUID	QTY	
38AXZ07	1-1/8 [28.6]	3/8 [9.5]	1	
38AXZ08	1-1/8 [28.6]	1/2 [12.7]	1	
38AXZ12	1-3/8 [34.9]	1/2 [12.7]	1	
38AXZ14	1-3/8 [34.9]	5/8 [15.9]	1	
38AXD12	1-1/8 [28.6]	3/8 [9.5]	2	
38AXD14	1-3/8 [34.9]	1/2 [12.7]	2	
38AXO07	1-1/8 [28.6]	3/8 [9.5]	1	
38AXO08	1-1/8 [28.6]	1/2 [12.7]	1	
38AXO12	1-3/8 [34.9]	1/2 [12.7]	1	

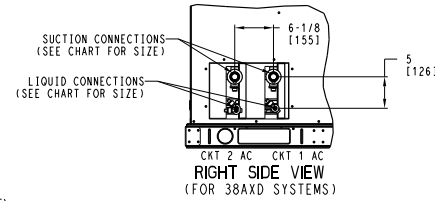

RIGHT SIDE VIEW
(FOR 38AXD SYSTEMS)

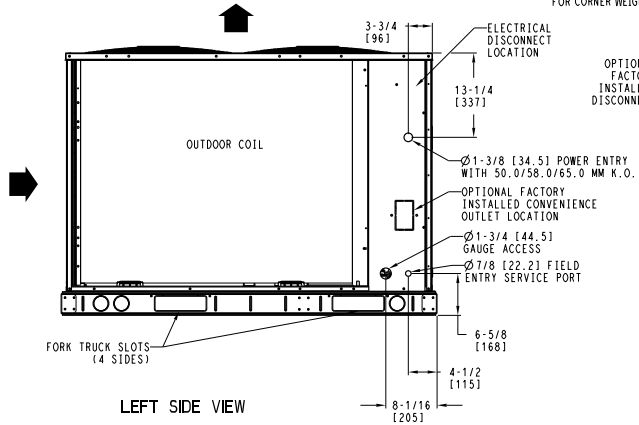

LEFT SIDE VIEW

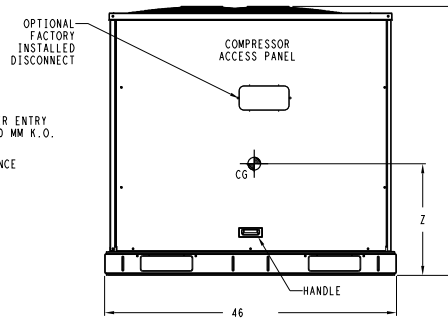

FRONT VIEW

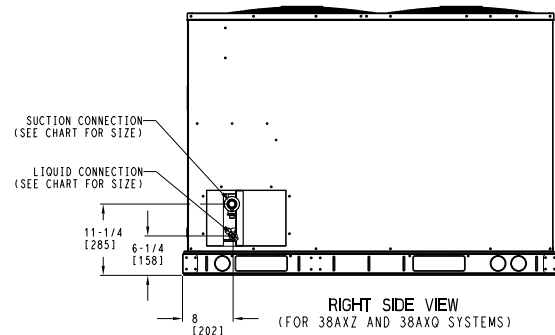

RIGHT SIDE VIEW
(FOR 38AXZ AND 38AXO SYSTEMS)

ITC CLASSIFICATION	SHEET	DATE	SUPERCEDES	CONDENSING UNIT	818A002464	REV
U.S. ECCN:NSR	2 OF 2	7/15/24	-	38AXZ/ 38AXD/ 38AXO-07/08/12/14		-



Base unit dimensions

38AXD/Z 16 Base Unit Dimensions

UNIT	ELECTRICAL CHARACTERISTICS	STD. UNIT WT.		CORNER A		CORNER B		CORNER C		CORNER D		CENTER OF GRAVITY			UNIT HEIGHT
		LBS.	KG.	LBS.	KG.	LBS.	KG.	LBS.	KG.	LBS.	KG.	X	Y	Z	H
38AXZ16 (RTPF)	208/230-3-60,460-3-60,575-3-60	731	332	237	107	172	78	135	61	186	84	38 [965.2]	19 [482.6]	17 [431.8]	50-3/8 [1279.2]
38AXD16 (RTPF)	208/230-3-60,460-3-60,575-3-60	731	332	237	107	172	78	135	61	186	84	38 [965.2]	19 [482.6]	17 [431.8]	50-3/8 [1279.2]
38AXO16 (RTPF)	208/230-3-60,460-3-60,575-3-60	768	348	236	107	183	83	153	69	196	89	39 [990.6]	20 [508]	23 [584.2]	50-3/8 [1279.2]

Carrier THIS DOCUMENT IS THE PROPERTY OF CARRIER CORPORATION AND IS DELIVERED UPON THE EXPRESS CONDITION THAT THE CONTENTS WILL NOT BE DISCLOSED OR USED WITHOUT CARRIER CORPORATION'S WRITTEN CONSENT. SUBMISSION OF THESE DRAWINGS OR DOCUMENTS DOES NOT CONSTITUTE PART PERFORMANCE OR ACCEPTANCE OF CONTRACT.

- NOTES:
- MINIMUM CLEARANCE (LOCAL CODES OR JURISDICTION MAY PREVAIL):
 - BOTTOM TO COMBUSTIBLE SURFACES: 0 INCHES.
 - OUTDOOR COIL, FOR PROPER AIR FLOW: 36 INCHES ONE SIDE, 12 INCHES THE OTHER. THE SIDE GETTING THE GREATER CLEARANCE IS OPTIONAL.
 - OVERHEAD: 60 INCHES, TO ASSURE PROPER OUTDOOR FAN OPERATION.
 - BETWEEN UNITS: CONTROL BOX SIDE, 42 INCHES PER NEC.
 - BETWEEN UNIT AND UNGROUNDED SURFACES: CONTROL BOX SIDE, 36 INCHES PER NEC.
 - BETWEEN UNIT AND BLOCK OR CONCRETE WALLS AND OTHER GROUNDED SURFACES: CONTROL BOX SIDE, 42 INCHES PER NEC.
 - WITH EXCEPTION OF THE CLEARANCE FOR THE OUTDOOR COIL AS STATED IN NOTE 1B, A REMOVABLE FENCE OR BARRICADE REQUIRES NO CLEARANCE.
 - UNITS MAY BE INSTALLED ON COMBUSTIBLE FLOORS MADE FROM WOOD OR CLASS A, B OR C ROOF COVERING MATERIAL.

UNIT	SERVICE VALVE CONNECTIONS		QTY
	SUCTION	LIQUID	
38AXZ16	1-3/8 [34.9]	5/8 [15.9]	1 EA
38AXD16	1-3/8 [34.9]	1/2 [12.7]	2 EA
38AXO16	1-3/8 [34.9]	1/2 [12.7]	2 EA

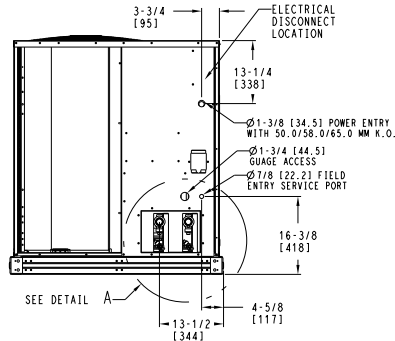

LEFT SIDE VIEW (FOR 38AXD/38AXQ SYSTEMS)

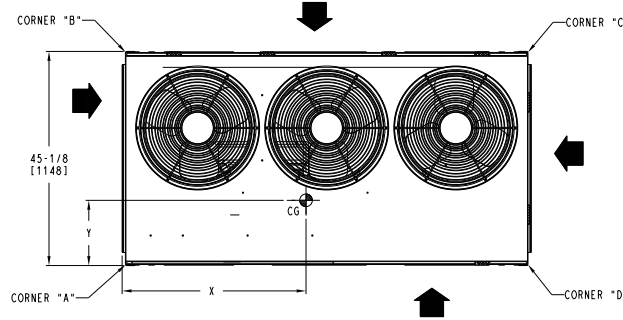

TOP VIEW

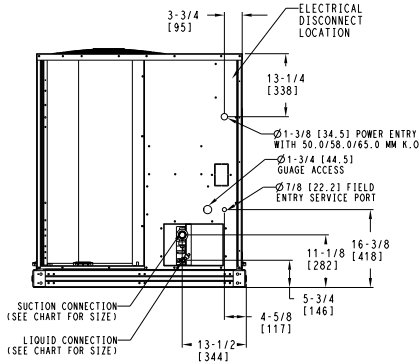

LEFT SIDE VIEW (FOR 38AXZ SYSTEMS)

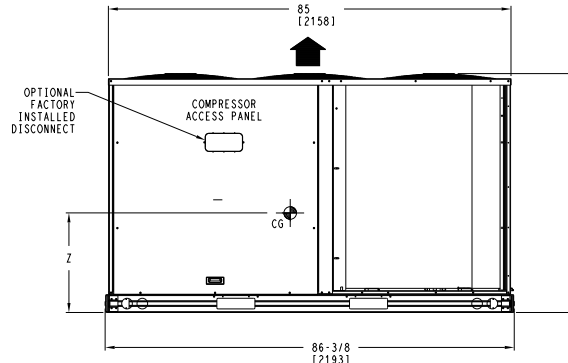

FRONT VIEW

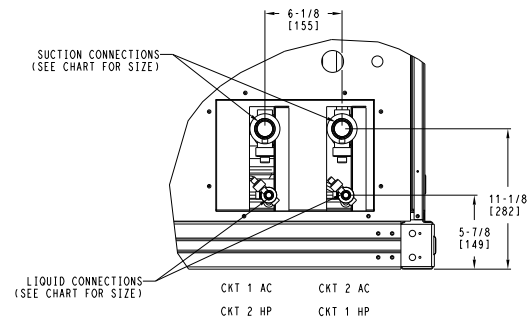

DETAIL A (NOTE POSITION OF CKT 1)

CG CENTER OF GRAVITY
DIRECTION OF AIR FLOW
DIMENSIONS IN [] ARE IN MM

ITC CLASSIFICATION U.S. ECCN:NSR	SHEET 1 OF 1	DATE 7/15/24	SUPERCEDES -	38AXZ, 38AXD, 38AXO 16 CONDENSING UNIT	38AU002467	REV -
-------------------------------------	-----------------	-----------------	-----------------	--	------------	----------



38AXZ 25, 38AXD 25-28 Base Unit Dimensions

UNIT	ELECTRICAL CHARACTERISTICS	STD. UNIT WT.		CORNER A		CORNER B		CORNER C		CORNER D		CENTER OF GRAVITY			UNIT HEIGHT				
		LBS.	KG.	LBS.	KG.	LBS.	KG.	LBS.	KG.	LBS.	KG.	X	Y	Z	H				
38AXZ25 (RTPF)	208/230-3-60,460-3-60,575-3-60	978	444	360	163	188	85	147	67	283	128	38	[965.2]	23	[584.2]	17	[431.8]	50-3/8	[1279.2]
38AXD25 (RTPF)	208/230-3-60,460-3-60,575-3-60	978	444	360	163	188	85	147	67	283	128	38	[965.2]	23	[584.2]	17	[431.8]	50-3/8	[1279.2]
38AXD28 (RTPF)	208/230-3-60,460-3-60,575-3-60	1174	533	377	171	267	121	220	100	310	141	41	[1041.4]	28	[711.2]	17	[431.8]	50-3/8	[1279.2]
38AXQ25 (RTPF)	208/230-3-60,460-3-60,575-3-60	1015	460	354	161	224	102	170	77	268	122	37	[939.8]	26	[660.4]	23	[584.2]	50-3/8	[1279.2]



THIS DOCUMENT IS THE PROPERTY OF CARRIER CORPORATION AND IS DELIVERED UPON THE EXPRESS CONDITION THAT THE CONTENTS WILL NOT BE DISCLOSED OR USED WITHOUT CARRIER CORPORATION'S WRITTEN CONSENT.

SUBMISSION OF THESE DRAWINGS OR DOCUMENTS DOES NOT CONSTITUTE PART PERFORMANCE OR ACCEPTANCE OF CONTRACT.

- NOTES:
- MINIMUM CLEARANCE (LOCAL CODES OR JURISDICTION MAY PREVAIL):
 - A. BOTTOM TO COMBUSTIBLE SURFACES: 0 INCHES.
 - B. OUTDOOR COIL FOR PROPER AIR FLOW: 36 INCHES ONE SIDE, 12 INCHES THE OTHER, THE SIDE GETTING THE GREATER CLEARANCE IS OPTIONAL.
 - C. OVERHEAD: 60 INCHES, TO ASSURE PROPER OUTDOOR FAN OPERATION.
 - D. BETWEEN UNITS: CONTROL BOX SIDE, 42 INCHES PER NEC.
 - E. BETWEEN UNIT AND UNGROUNDED SURFACES: CONTROL BOX SIDE: 36 INCHES PER NEC.
 - F. BETWEEN UNIT AND BLOCK OR CONCRETE WALLS AND OTHER GROUNDED SURFACES: CONTROL BOX SIDE, 42 INCHES PER NEC.
 - WITH EXCEPTION OF THE CLEARANCE FOR THE OUTDOOR COIL AS STATED IN NOTE 1B, A REMOVABLE FENCE OR BARRICADE REQUIRES NO CLEARANCE.
 - UNITS MAY BE INSTALLED ON COMBUSTIBLE FLOORS MADE FROM WOOD OR CLASS A, B OR C ROOF COVERING MATERIAL.

UNIT	SERVICE VALVE CONNECTIONS		QTY
	SUCTION	LIQUID	
38AXZ25	1-5/8 [41.3]	5/8 [15.9]	1 EA
38AXD25	1-3/8 [34.9]	1/2 [12.7]	2 EA
38AXD28	1-3/8 [34.9]	1/2 [12.7]	2 EA
38AXQ25	1-3/8 [34.9]	1/2 [12.7]	2 EA

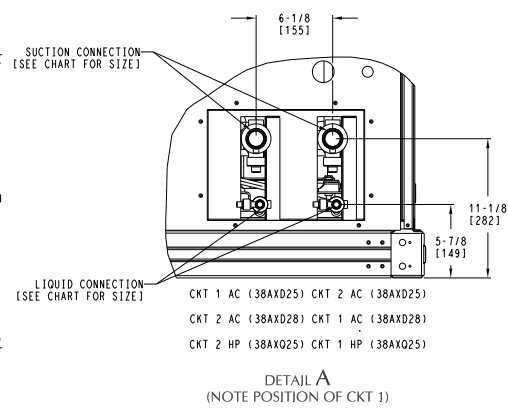
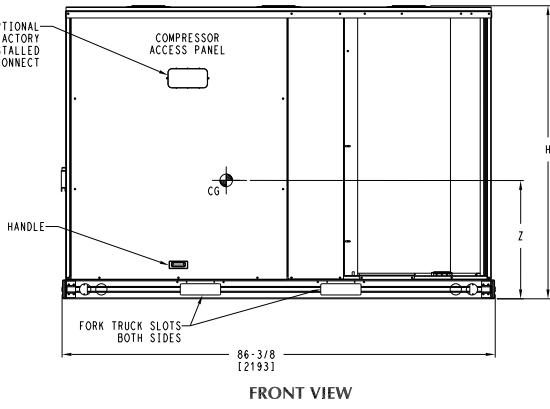
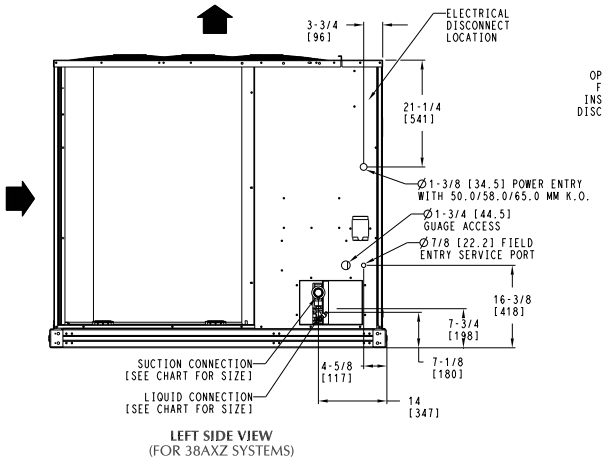
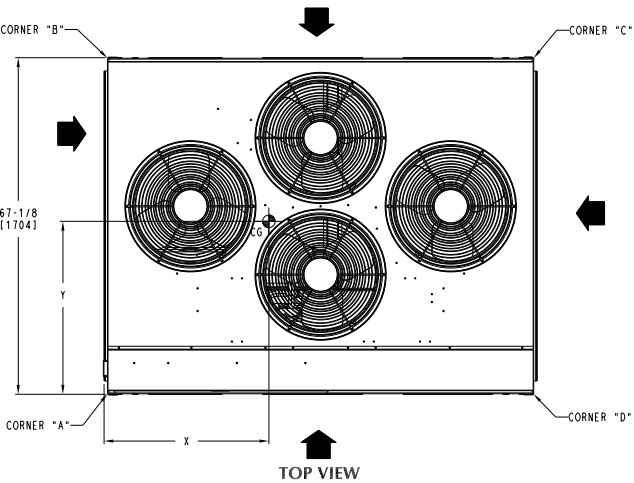
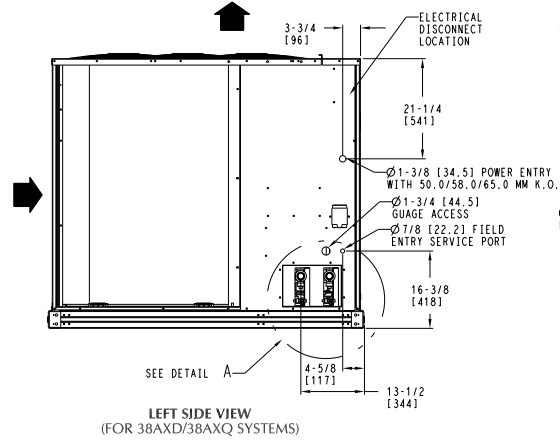
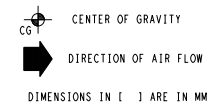

DATE	SUPERCEDES	38AXZ, 38AXD, 38AXQ 25/28 CONDENSING UNIT	38AU002470	-
7/16/24	-			



Corner Weights^a

UNIT	STD. UNIT WT.		CORNER A		CORNER B		CORNER C		CORNER D		CENTER OF GRAVITY ^b			UNIT HEIGHT ^b
	lb	kg	lb	kg	lb	kg	lb	kg	lb	kg	X	Y	Z	H
38AXZ*07	389	176	141	64	96	44	62	28	91	41	18 [457.2]	24 [609.6]	21 [533.4]	42 3/8 [1076.0]
38AXZ*08	430	195	142	64	96	44	76	34	111	50	18 [457.2]	24 [609.6]	21 [533.4]	42 3/8 [1076.0]
38AXZ*12	490	222	177	80	120	54	78	35	114	52	18 [457.2]	24 [609.6]	24 [609.6]	50 3/8 [1279.2]
38AXZ*14	598	271	195	88	142	64	110	50	151	68	20 [508.0]	25 [635.0]	24 [609.6]	50 3/8 [1279.2]
38AXZ*16	731	332	237	107	172	78	135	61	186	84	38 [965.2]	19 [482.6]	17 [431.8]	50 3/8 [1279.2]
38AXZ*25	978	444	360	163	188	85	147	67	283	128	38 [965.2]	23 [584.2]	17 [431.8]	50 3/8 [1279.2]
38AXD*12	516	234	185	84	117	53	83	38	131	59	19 [482.6]	23 [584.2]	24 [609.6]	50 3/8 [1279.2]
38AXD*14	654	297	214	97	155	70	120	54	165	75	20 [508.0]	25 [635.0]	24 [609.6]	50 3/8 [1279.2]
38AXD*16	731	332	237	107	172	78	135	61	186	84	38 [965.2]	19 [482.6]	17 [431.8]	50 3/8 [1279.2]
38AXD*25	978	444	360	163	188	85	147	67	283	128	38 [965.2]	23 [584.2]	17 [431.8]	50 3/8 [1279.2]
38AXD*28	1174	533	377	171	267	121	220	100	310	141	41 [1041.4]	28 [711.2]	17 [431.8]	50 3/8 [1279.2]

NOTE(S):

- a. See Base Unit Dimensions on pages 13-15 for corner locations.
- b. Dimensions are in inches [mm].

38AX ITEMS	FACTORY-INSTALLED OPTION	FIELD-INSTALLED ACCESSORY
E-Coated Aluminum-Fin Coils	X	
Louvered Hail Guard	X	X
Low-Ambient Temperature Kit	X	X
Non-Fused Disconnect Switch ^a	X	
Powered Convenience Outlet	X	
Pre-Coated Coils	X	
Thermostats		X
Un-powered Convenience Outlet	X	

NOTE(S):

- a. Non-fused disconnect switch cannot be used when unit MOCP electrical rating exceeds 80 amps.

38AXZ/38AXD factory-installed options

E-coated aluminum-fin coils

These coils have a flexible and durable epoxy coating uniformly applied to all coil surfaces. Unlike brittle phenolic dip and bake coatings, E-coating provides superior protection with unmatched flexibility, edge coverage, metal adhesion, thermal performance, and most importantly, corrosion resistance.

Pre-coated coils

These coils provide protection in mild coastal environments.

Low-ambient temperature kit (-20°F [-29°C])

This kit controls outdoor-fan motor operation to maintain the correct head pressure at low outdoor ambient temperatures.

Louvered hail guard

This guard protects coils against damage from flying debris and hail.

Non-fused disconnect switch

This switch is used to remove power locally at the condensing unit. This switch also includes a power lockout capability to protect the service person. This lockout switch saves the service person time and effort because there is no need to access a distant disconnect switch while servicing the unit.

NOTE: Non-fused disconnect switch cannot be used when unit MOCP electrical rating exceeds 80 amps.

38AXZ/D field-installed accessories

Low-ambient temperature kit (-20°F [-29°C])

This accessory controls outdoor-fan motor operation to maintain the correct head pressure at low outdoor ambient temperatures.

Louvered hail guard

This guard protects coils against damage from flying debris and hail.

Thermostats

These accessories provide both programmable and non-programmable capability with the new Carrier line of commercial programmable thermostats. The Commercial Electronic thermostats provide 7-day programmable capability for economical applications.

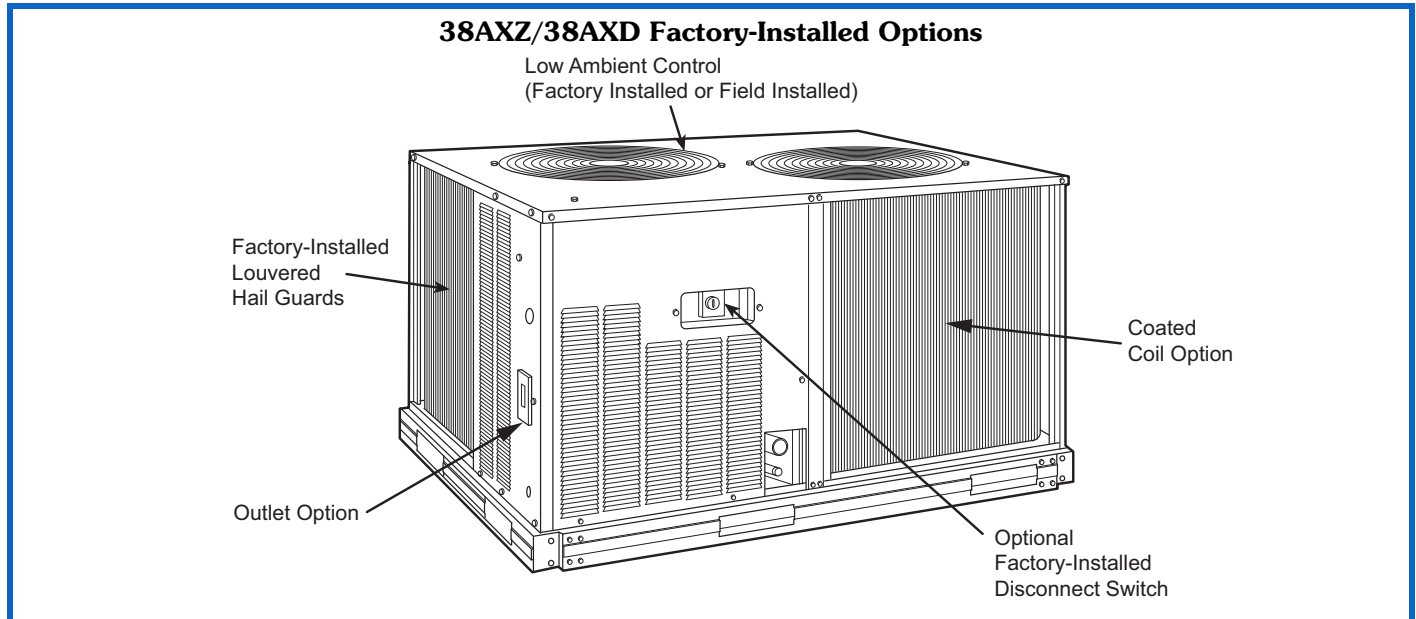

40RLA ITEMS	FACTORY-INSTALLED OPTION	FIELD-INSTALLED ACCESSORY
Alternate Drives	X	
Alternate Fan Motors	X	
CO ₂ Sensors		X
Condensate Drain Trap		X
Discharge Duct Adapter (40RLA 07-12 only)		X
Discharge Plenum		X
Economizer		X
Electric Heater		X
Hot Water Heating Coils (2 row)		X
Optional VFD Display Kit (40RLA sizes 14-30 only)		X
Overhead Suspension Package		X
Pre-painted Units	X	
Programmable Thermostats		X
Return Air Grille		X
Staged Air Volume (SAV)	X	
Steam Heating Coil (1 row)		X

40RLA factory-installed options

Alternate fan motors and drives

Alternate fan motors and drives are available to provide the widest possible range of performance.

Pre-painted steel constructed units

Pre-painted units are available from the factory for applications that require painted units. Units are painted with American Sterling Gray color.

Staged Air Volume (SAV™) system

Our SAV units will automatically adjust the indoor fan motor speed in sequence with the unit's cooling operation. Per ASHRAE 90.1 2010 standard section 6.4.3.10.b, during the first stage of cooling operation the fan motor (either ECM or controlled by VFD) will adjust to provide two-thirds of the total cfm established for the unit. When a call for the second stage of cooling is required, the fan motor will allow the total cfm (100%) established for the unit. During the heating mode the fan motor will allow total design cfm (100%) operation and during the ventilation mode the fan motor will allow operation to two-thirds of total cfm.

40RLA field-installed accessories

Optional VFD display kit (sizes 14-30)

There is an optional VFD display kit offered (as an accessory) for 40RLA units to allow the user to troubleshoot any VFD faults in the field after start-up.

NOTE: Do not use the VFD display kit to adjust the frequency and voltage in the VFD to required performance requirements. This could lead to decreased life of the motor and VFD.

Two-row hot water coils

Two-row hot water coils have copper tubes mechanically bonded to aluminum plate fins and non-ferrous headers.

One-row steam coil

One-row steam coils have copper tubes and aluminum fins.

The Inner Distributing Tube (IDT) design provides uniform temperatures across the coil face. The steam coil has a broad operating pressure range; up to 20 psi (138 kPag) at 260°F (126°C). The IDT steam coils are especially suited to applications where sub-freezing air enters the unit.

Electric heater

Electric heaters are available as factory-supplied, field-installed accessories for nominal 240v, 480v, and 575v, 3-phase, 60 Hz units. Electric heaters are UL and CSA, agency-approved. They have single-point power wiring. The heater assembly includes contactors with 24-v coils, power wiring, 24-v control wiring terminal blocks, and a hinged access panel. Electric heaters should not be used with an air discharge plenum.

Economizer

Provides ventilation air and provides “free” cooling if the outside ambient temperature and humidity are suitable. The economizer can also be used in conjunction with Carrier Comfort System thermostats and CO₂ sensors to help meet indoor air quality requirements. The economizer can be used in both vertical and horizontal positions.

Discharge plenum

Discharge plenum directs the air discharge directly into the occupied space; integral horizontal and vertical louvers enable redirection of airflow. This accessory is available unpainted or painted. Field assembly is required (only applicable for vertical application).

Return-air grille

The return-air grille provides a protective barrier over the return-air opening and gives a finished appearance to units installed in the occupied space. This accessory is available unpainted or painted.

Overhead suspension package

The overhead suspension package includes necessary brackets to support units in horizontal ceiling installations.

CO₂ sensors

CO₂ sensors can be used in conjunction with the economizer accessory to help meet indoor air quality requirements. The sensor signals the economizer to open when the CO₂ level in the space exceeds the set point. A Carrier Comfort System programmable thermostat can be used to override the sensor if the outside-air temperature is too high or too low.

Condensate drain trap

The condensate drain trap includes an overflow shutoff switch that can be wired to turn off the unit if the trap becomes plugged. Kit also includes a wire harness that can be connected to an alarm if desired. The transparent trap is designed for easy service and maintenance.

Discharge duct adapter (sizes 07-12)

This accessory is required for replacements using 40RLA units with or without electric heat. It is not required for new installations or when using steam coil, hot water coil, or discharge plenum accessories.

40RLA with Discharge Plenum Return-Air Grille and Subbase

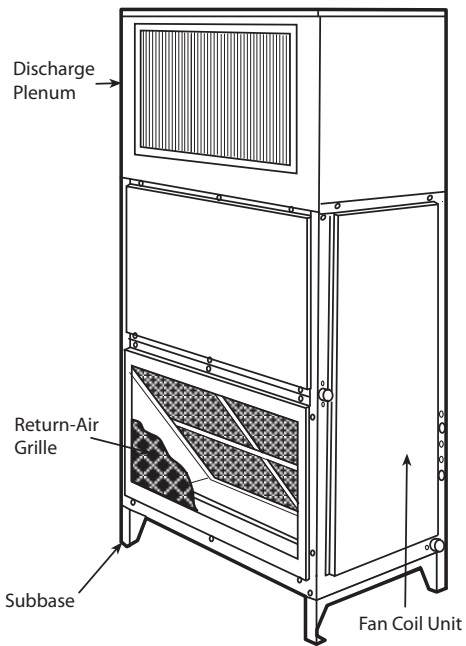

40RLA with Hot Water or Steam Coil

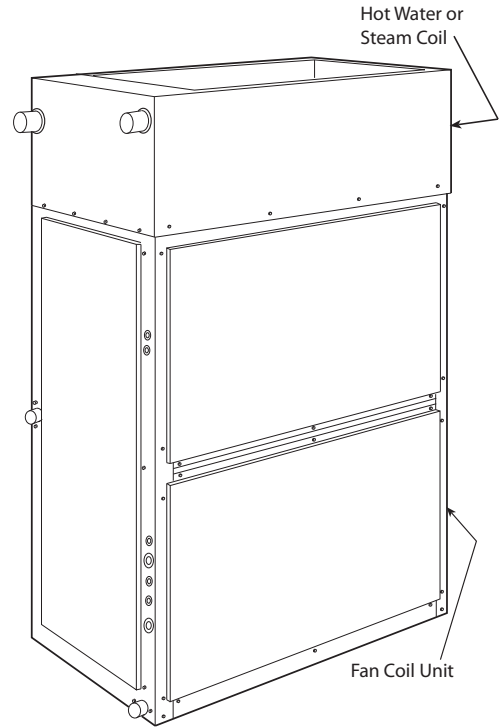

40RLA with Economizer

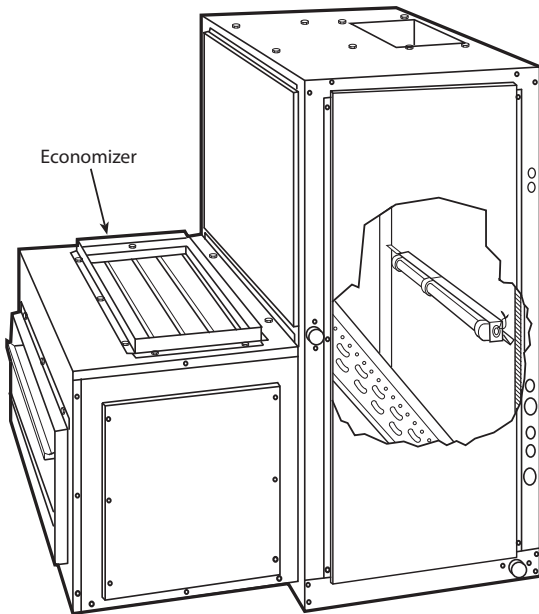

40RLA with Condensate Trap

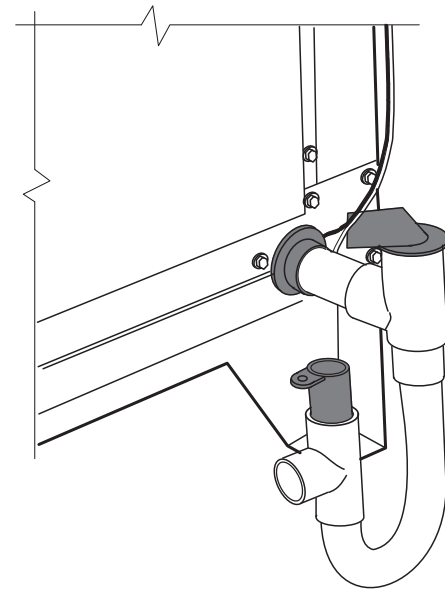

Typical Single Circuit/Two-Stage Wiring Diagram, 7.5 Ton (460-3-60 Unit Shown)

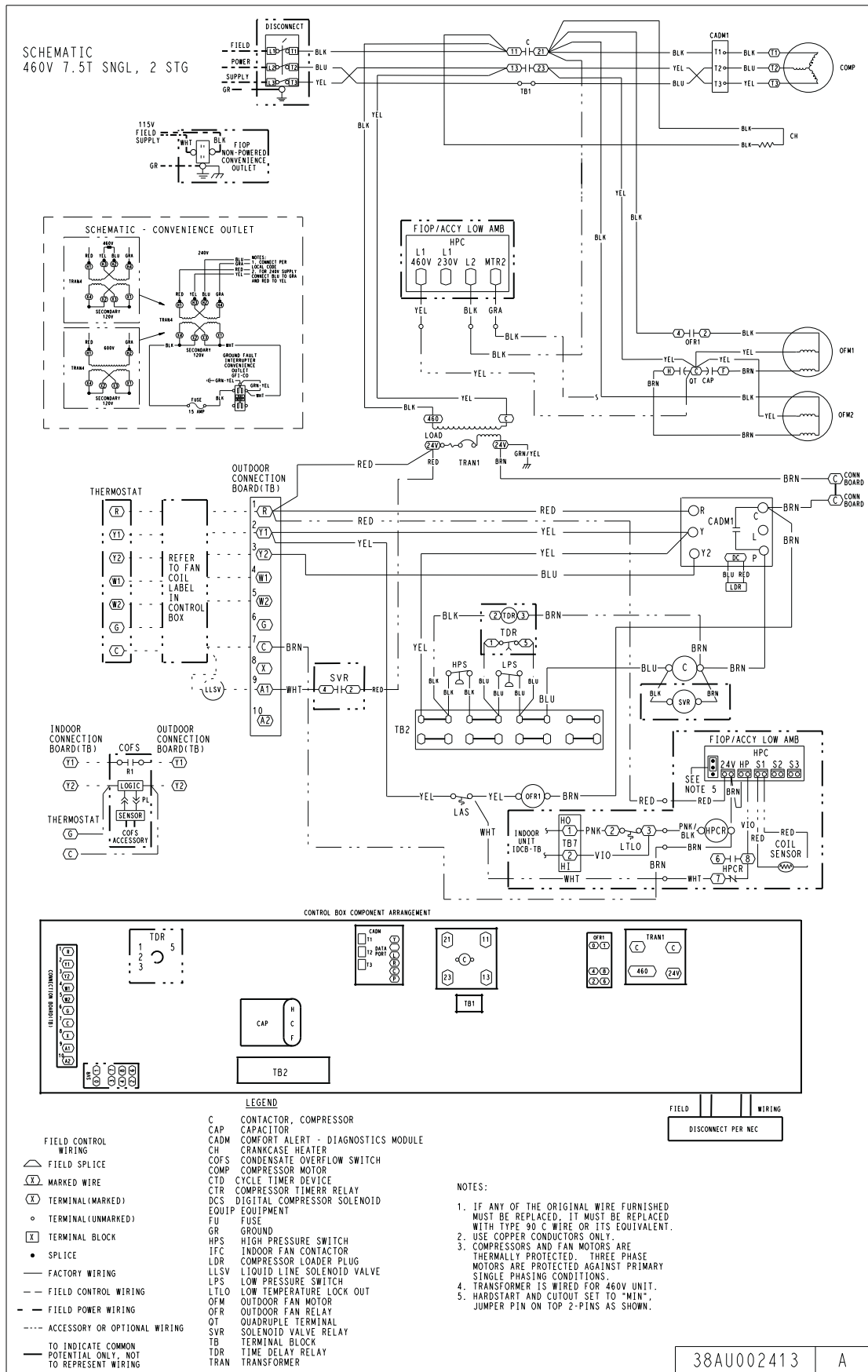

Typical Single Circuit/Two Stage Wiring Diagram, 15 Ton (460-3-60 Unit Shown)

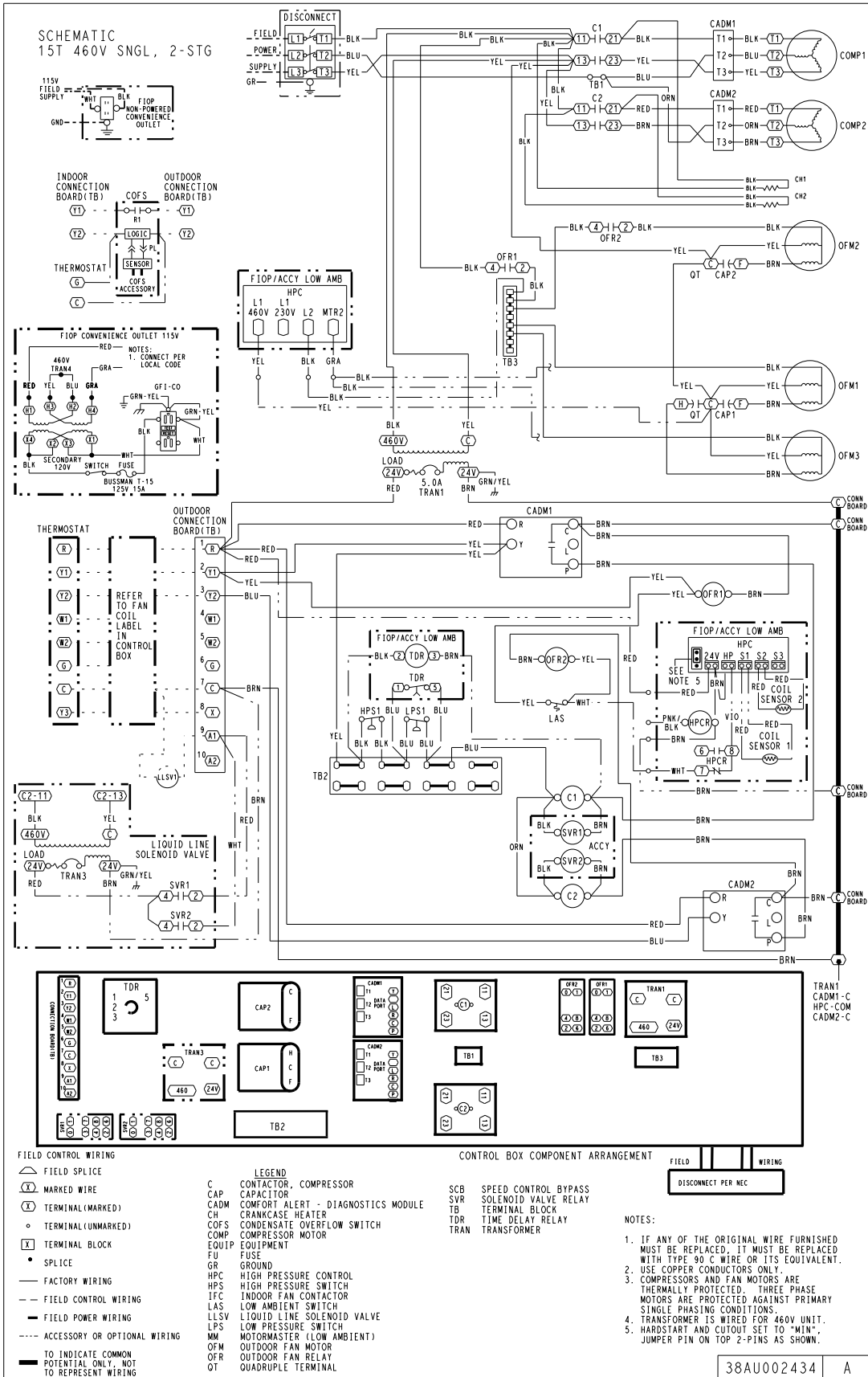

Typical Single Circuit/Two Stage Wiring Diagram, 20 Ton (460-3-60 Unit Shown)

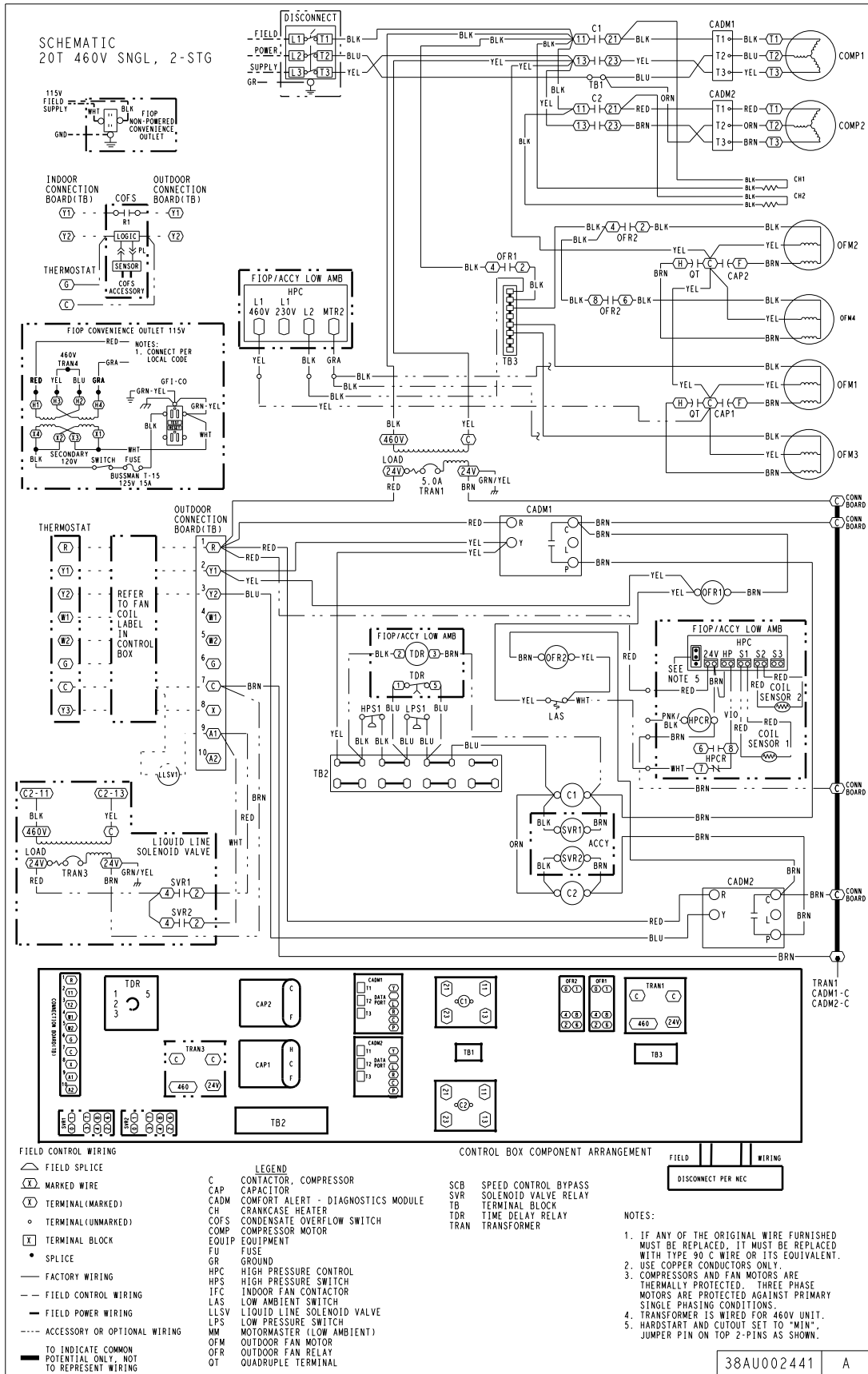

Typical Dual Circuit/Three-Stage Wiring Diagram, 10-12.5 Ton (460-3-60 Unit Shown)

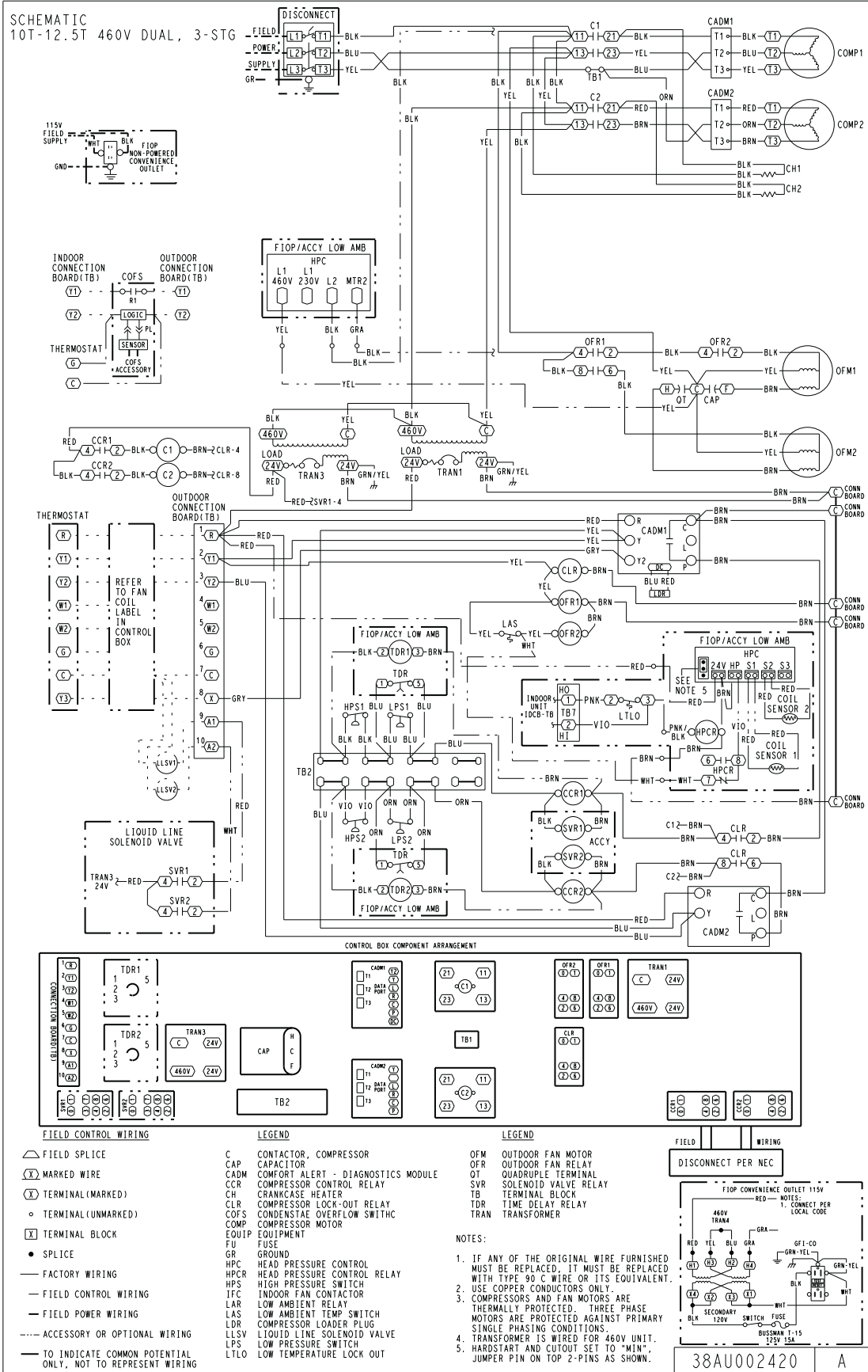

Typical Dual Circuit/Three Stage Wiring Diagram, 15 Ton (460-3-60 Unit Shown)

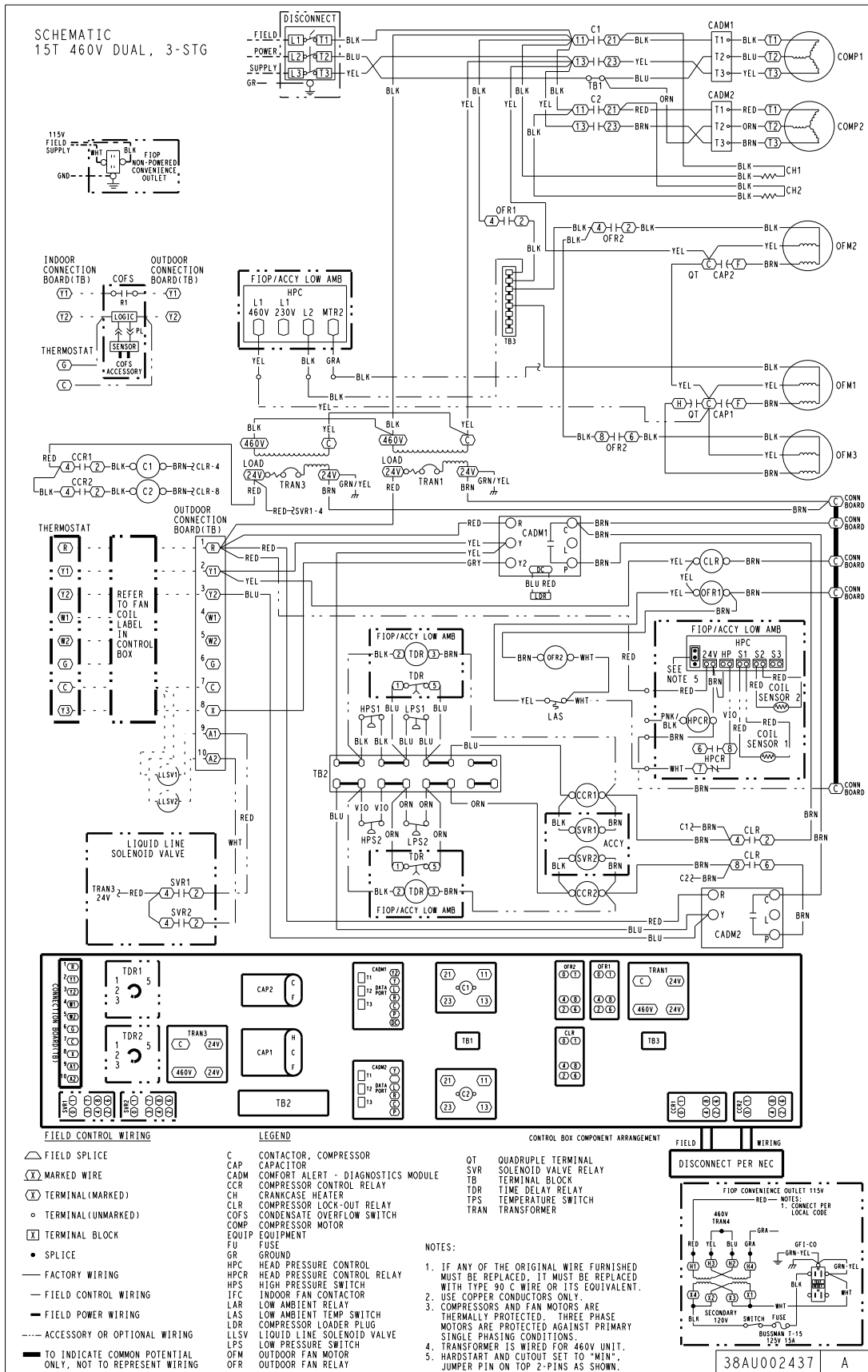

Typical Dual Circuit/Three Stage Wiring Diagram, 25 Ton (460-3-60 Unit Shown)

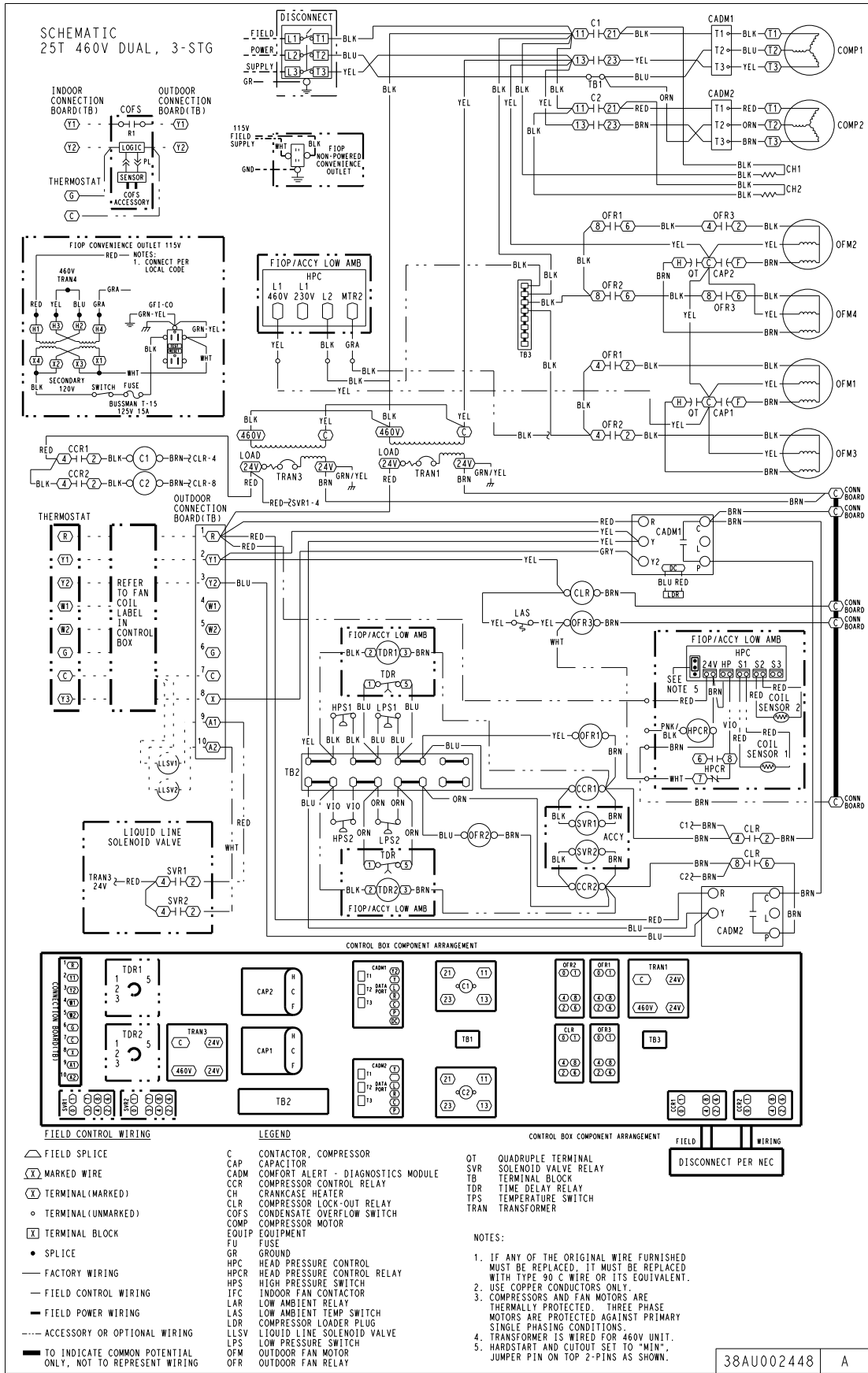

38AU002448 A

Roof Installation and Ceiling-Mounted Fan Coil

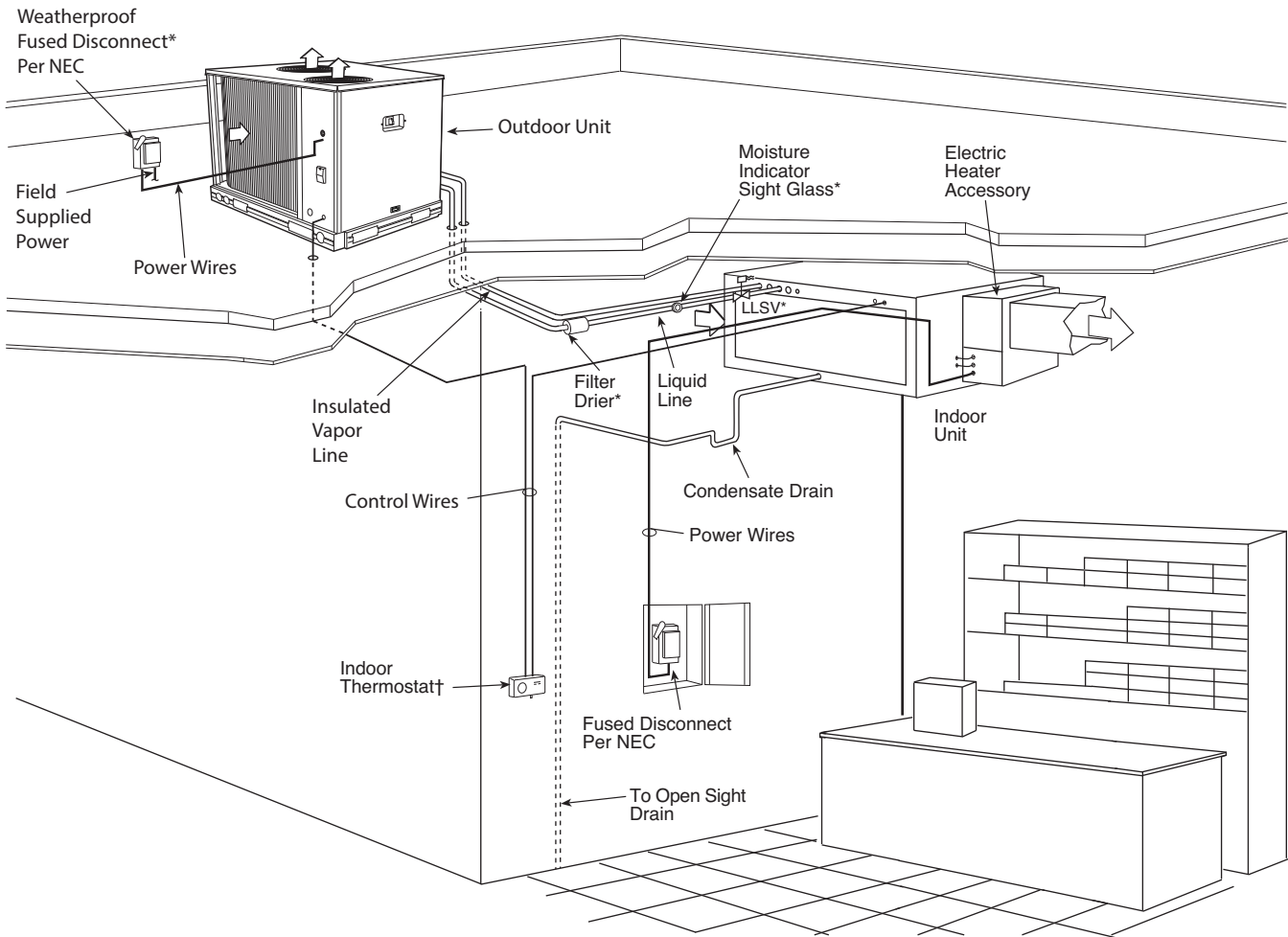

LEGEND

- LLSV** — Liquid Line Solenoid Valve
- NEC** — National Electrical Code
- TXV** — Thermostatic Expansion Valve

* Field-supplied.

† Double riser may be required. Consult condensing unit product data catalog for details.

NOTE(S):

1. All piping must follow standard refrigerant piping techniques. Refer to Carrier System Design Manual for details.
2. All wiring must comply with the applicable local and national codes.
3. Wiring and piping shown are general points-of-connection guides only and are not intended for, or to include all details for, a specific installation.
4. Liquid line solenoid valve (solenoid drop control) is recommended to prevent refrigerant migration to the compressor.
5. Internal factory-supplied TXVs not shown.

Roof Installation and a Vertical Discharge Fan Coil

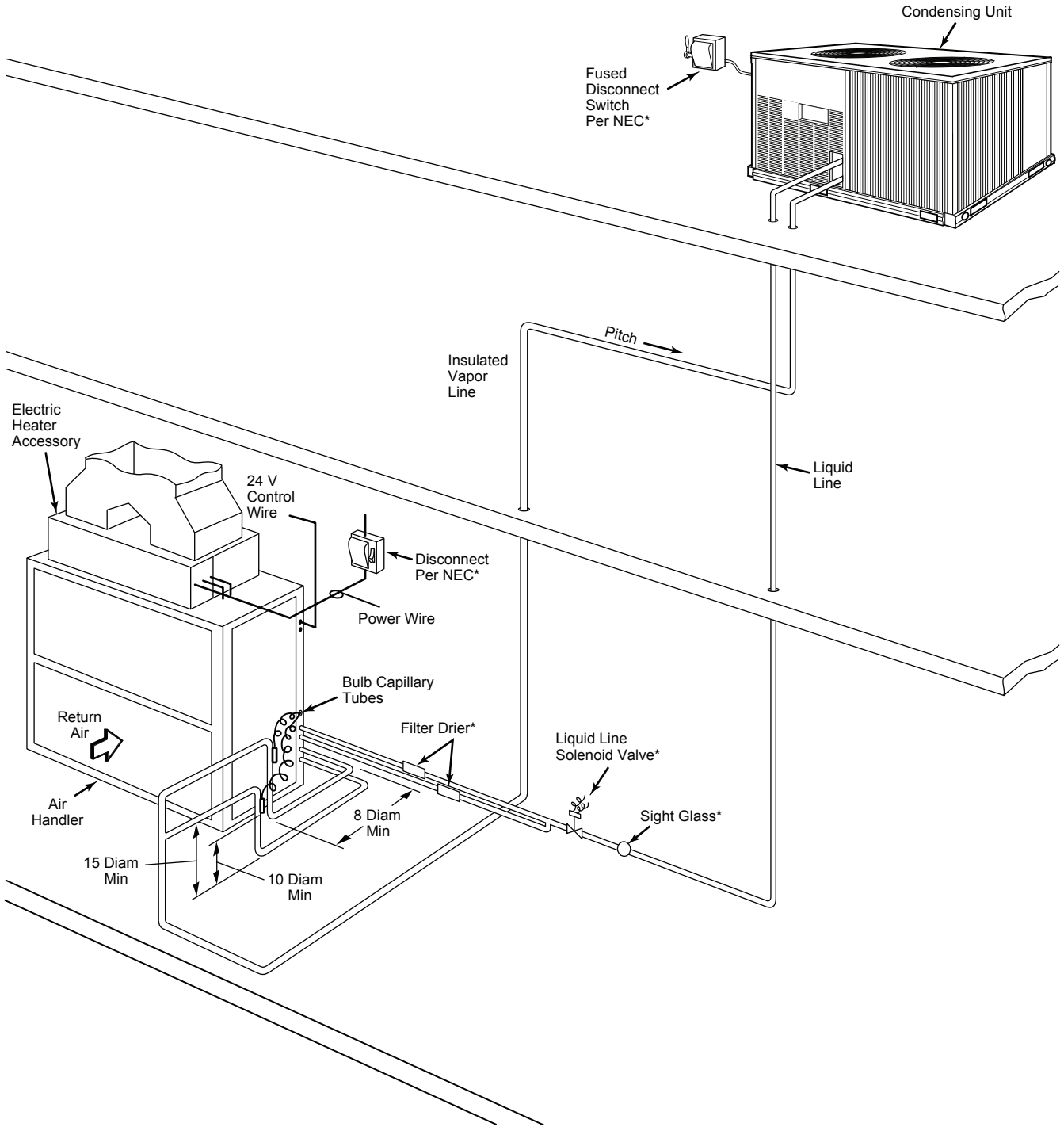

LEGEND

- DIAM** — Diameter
- NEC** — National Electrical Code
- TXV** — Thermostatic Expansion Valve
- Piping

*Field supplied.

NOTE(S):

1. All piping must follow standard refrigerant piping techniques. Refer to System Design Manual for details.
2. All wiring must comply with applicable local and national codes.
3. Wiring and piping shown are general points-of-connection guides only and are not intended for, or to include all details for, a specific installation.
4. Liquid line solenoid valve (solenoid drop control) is recommended to prevent refrigerant migration to the compressor on line links above 75 feet (23 meters).
5. Internal factory-supplied TXVs and check valves not shown.

Ground Installation and Vertical Discharge Fan Coil

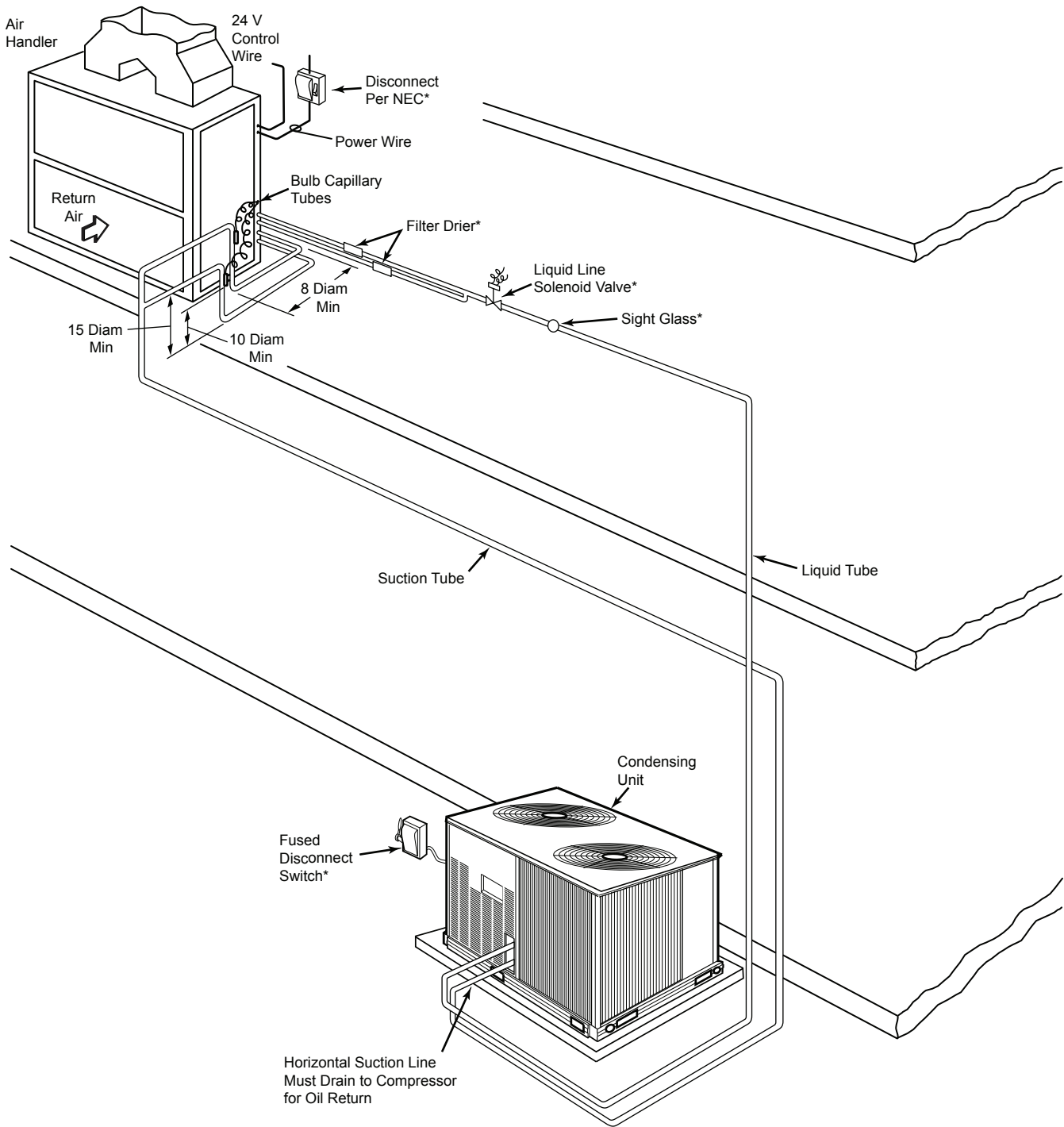

LEGEND

- DIAM** — Diameter
- NEC** — National Electrical Code
- TXV** — Thermostatic Expansion Valve
-  Piping

*Field supplied.

NOTE(S):

1. All piping must follow standard refrigerant piping techniques. Refer to System Design Manual for details.
2. All wiring must comply with applicable local and national codes.
3. Wiring and piping shown are general points-of-connection guides only and are not intended for, or to include all details for, a specific installation.
4. Liquid line solenoid valve (solenoid drop control) is recommended to prevent refrigerant migration to the compressor on line links above 75 feet (23 meters).
5. Internal factory-supplied TXVs and check valves not shown.

38AXZD07 Total Unit — Condenser Only Ratings — 60 Hz

SST (°F)		Air Temperature Entering Condenser (°F)					
		85	95	100	105	115	125
20	TC	44.6	42.2	40.9	39.5	36.8	34.0
	kW	3.7	4.2	4.5	4.8	5.4	6.1
	SDT	101.0	110.4	115.0	119.7	128.9	138.2
25	TC	49.3	46.6	45.2	43.8	40.9	37.8
	kW	3.8	4.3	4.6	4.9	5.5	6.2
	SDT	102.3	111.7	116.3	120.9	130.1	139.4
30	TC	54.4	51.4	49.9	48.3	45.1	41.8
	kW	3.8	4.4	4.7	5.0	5.6	6.3
	SDT	103.8	113.0	117.6	122.3	131.4	140.7
35	TC	59.7	56.5	54.8	53.1	49.6	46.1
	kW	3.9	4.4	4.7	5.0	5.7	6.4
	SDT	105.3	114.5	119.1	123.7	132.8	142.1
40	TC	65.4	61.9	60.0	58.2	54.4	50.5
	kW	4.0	4.5	4.8	5.1	5.8	6.5
	SDT	106.9	116.1	120.7	125.2	134.4	143.6
45	TC	71.4	67.6	65.6	63.6	59.4	55.2
	kW	4.0	4.6	4.9	5.2	5.9	6.6
	SDT	108.7	117.8	122.4	126.9	136.0	145.1
50	TC	77.8	73.6	71.4	69.2	64.7	60.1
	kW	4.1	4.7	5.0	5.3	6.0	6.7
	SDT	110.6	119.7	124.2	128.7	137.6	146.4

38AXZD08 Total Unit — Condenser Only Ratings — 60 Hz

SST (°F)		Air Temperature Entering Condenser (°F)					
		85	95	100	105	115	125
20	TC	59.5	56.3	54.6	52.8	49.2	45.2
	kW	5.2	5.9	6.3	6.6	7.4	8.4
	SDT	100.1	109.3	113.9	118.5	127.6	136.6
25	TC	65.8	62.2	60.3	58.3	54.2	49.8
	kW	5.3	6.0	6.3	6.7	7.5	8.5
	SDT	101.4	110.6	115.1	119.7	128.7	137.6
30	TC	72.5	68.5	66.4	64.2	59.6	54.7
	kW	5.4	6.1	6.4	6.8	7.6	8.6
	SDT	102.9	112.0	116.5	121.0	129.9	138.7
35	TC	79.7	75.2	72.9	70.5	65.4	59.9
	kW	5.5	6.2	6.5	6.9	7.7	8.7
	SDT	104.5	113.5	117.9	122.3	131.1	139.8
40	TC	87.4	82.4	79.8	77.2	71.6	65.6
	kW	5.6	6.3	6.7	7.0	7.8	8.7
	SDT	106.2	115.0	119.4	123.8	132.4	141.0
45	TC	95.7	90.1	87.3	84.3	78.1	71.5
	kW	5.8	6.4	6.8	7.2	8.0	8.9
	SDT	108.0	116.7	121.0	125.2	133.7	142.2
50	TC	104.4	98.3	95.1	91.9	85.1	77.8
	kW	5.9	6.6	6.9	7.3	8.1	9.0
	SDT	109.9	118.3	122.6	126.8	135.1	143.4

LEGEND

kW — Compressor Motor Power Input
SDT — Saturated Discharge Temperature (°F)
SST — Saturated Suction Temperature
TC — Total Capacity (1000 Btuh) gross

38AXZM12 Total Unit — Condenser Only Ratings — 60 Hz

SST (°F)		Air Temperature Entering Condenser (°F)					
		85	95	100	105	115	125
20	TC	75.7	71.7	69.6	67.4	62.6	58.2
	kW	6.6	7.3	7.7	8.1	9.0	10.1
	SDT	101.9	110.9	115.5	120.0	128.8	137.9
25	TC	83.2	78.7	76.3	73.9	68.7	62.9
	kW	6.7	7.5	7.9	8.3	9.3	10.3
	SDT	103.6	112.5	117.0	121.4	130.3	138.9
30	TC	91.2	86.2	83.5	80.8	75.0	68.7
	kW	6.9	7.7	8.1	8.5	9.5	10.5
	SDT	105.4	114.2	118.6	123.0	131.6	140.2
35	TC	99.6	94.1	91.1	88.6	81.7	74.6
	kW	7.1	7.9	8.3	8.7	9.7	10.7
	SDT	107.3	116.0	120.3	124.8	133.1	141.5
40	TC	108.6	102.4	99.1	96.4	88.4	80.8
	kW	7.3	8.1	8.5	8.9	9.9	10.9
	SDT	109.3	117.8	122.1	126.5	134.6	142.9
45	TC	118.0	111.1	107.5	104.6	96.7	87.2
	kW	7.5	8.3	8.7	9.2	10.1	11.1
	SDT	111.5	119.8	124.0	128.3	136.5	144.4
50	TC	127.9	120.2	116.2	113.0	104.4	95.0
	kW	7.8	8.5	8.9	9.4	10.3	11.4
	SDT	113.7	121.9	126.0	130.3	138.3	146.2

38AXZM14 Total Unit — Condenser Only Ratings — 60 Hz

SST (°F)		Air Temperature Entering Condenser (°F)					
		85	95	100	105	115	125
20	TC	91.3	85.8	82.9	79.8	73.2	66.0
	kW	8.5	9.8	10.5	11.3	13.1	15.2
	SDT	106.4	116.1	121.0	125.9	135.6	145.3
25	TC	100.6	94.8	91.7	88.5	81.6	74.2
	kW	8.6	9.8	10.5	11.3	13.0	15.1
	SDT	107.1	116.7	121.5	126.3	135.9	145.5
30	TC	110.2	104.1	100.9	97.5	90.3	82.5
	kW	8.7	9.9	10.6	11.3	13.0	15.0
	SDT	108.3	117.7	122.4	127.1	136.5	145.9
35	TC	120.3	113.7	110.3	106.7	99.2	91.0
	kW	8.8	10.0	10.7	11.4	13.1	15.0
	SDT	109.8	119.0	123.6	128.2	137.5	146.7
40	TC	130.7	123.6	119.9	116.1	108.1	99.6
	kW	9.0	10.2	10.9	11.6	13.2	15.1
	SDT	111.7	120.8	125.3	129.8	138.9	147.8
45	TC	141.5	133.9	129.8	125.7	117.2	108.3
	kW	9.2	10.5	11.1	11.9	13.5	15.3
	SDT	114.0	122.9	127.3	131.7	140.6	149.2
50	TC	152.6	144.3	140.0	135.6	126.5	117.3
	kW	9.5	10.7	11.4	12.1	13.8	15.6
	SDT	116.4	125.2	129.5	133.8	142.5	150.8

LEGEND

kW — Compressor Motor Power Input
SDT — Saturated Discharge Temperature (°F)
SST — Saturated Suction Temperature
TC — Total Capacity (1000 Btuh) gross

38AXDT12 Total Unit — Condenser Only Ratings — 60 Hz

SST (°F)		Air Temperature Entering Condenser (°F)					
		85	95	100	105	115	125
20	TC	77.4	73.0	70.7	68.4	63.4	58.1
	kW	6.8	7.7	8.2	8.6	9.7	10.9
	SDT	101.5	110.6	115.1	119.6	128.5	137.3
25	TC	85.4	80.6	78.1	75.6	70.1	64.4
	kW	7.0	7.8	8.3	8.8	9.9	11.0
	SDT	103.2	112.2	116.6	121.1	129.9	138.6
30	TC	93.9	88.6	85.9	83.1	77.2	71.0
	kW	7.1	8.0	8.5	9.0	10.0	11.2
	SDT	105.0	113.8	118.2	122.6	131.3	139.9
35	TC	102.9	97.1	94.1	91.1	84.6	77.8
	kW	7.3	8.1	8.6	9.1	10.2	11.4
	SDT	106.9	115.6	119.9	124.2	132.8	141.3
40	TC	112.4	106.1	102.8	99.4	92.3	84.9
	kW	7.4	8.3	8.8	9.3	10.4	11.6
	SDT	108.8	117.4	121.7	125.9	134.4	142.7
45	TC	122.4	115.5	111.8	108.0	100.3	92.1
	kW	7.6	8.5	9.0	9.5	10.6	11.8
	SDT	110.9	119.3	123.5	127.7	136.0	144.2
50	TC	132.8	125.1	121.1	117.0	108.5	97.7
	kW	7.7	8.6	9.1	9.7	10.8	11.9
	SDT	113.1	121.3	125.5	129.6	137.7	145.4

38AXDT12 Circuit A Unit — Condenser Only Ratings — 60 Hz

SST (°F)		Air Temperature Entering Condenser (°F)					
		85	95	100	105	115	125
20	TC	36.9	34.7	33.6	32.5	30.3	28.0
	kW	3.0	3.3	3.5	3.7	4.2	4.6
	SDT	100.2	109.3	113.9	118.4	127.4	136.4
25	TC	40.7	38.4	37.2	36.0	33.6	31.0
	kW	3.0	3.4	3.6	3.8	4.2	4.7
	SDT	101.8	110.8	115.3	119.8	128.7	137.6
30	TC	44.8	42.3	41.0	39.7	37.0	34.3
	kW	3.1	3.5	3.7	3.9	4.3	4.8
	SDT	103.4	112.4	116.8	121.3	130.1	138.9
35	TC	49.2	46.4	45.0	43.6	40.7	37.6
	kW	3.2	3.5	3.7	3.9	4.4	4.9
	SDT	105.2	114.1	118.4	122.8	131.5	140.2
40	TC	53.8	50.8	49.3	47.7	44.5	41.1
	kW	3.2	3.6	3.8	4.0	4.5	4.9
	SDT	107.1	115.8	120.1	124.4	133.0	141.6
45	TC	58.7	55.5	53.7	52.0	48.4	44.7
	kW	3.3	3.7	3.9	4.1	4.5	5.0
	SDT	109.0	117.6	121.9	126.1	134.6	143.0
50	TC	63.9	60.2	58.3	56.4	52.5	47.5
	kW	3.4	3.7	4.0	4.2	4.6	5.1
	SDT	111.1	119.5	123.7	127.9	136.2	144.1

LEGEND

kW — Compressor Motor Power Input
SDT — Saturated Discharge Temperature (°F)
SST — Saturated Suction Temperature
TC — Total Capacity (1000 Btuh) gross

38AXDT12 Circuit B Unit — Condenser Only Ratings — 60 Hz

SST (°F)		Air Temperature Entering Condenser (°F)					
		85	95	100	105	115	125
20	TC	40.6	38.3	37.1	35.8	33.1	30.1
	kW	3.9	4.4	4.6	4.9	5.5	6.2
	SDT	102.8	111.8	116.3	120.7	129.5	138.2
25	TC	44.7	42.2	40.9	39.5	36.6	33.4
	kW	3.9	4.4	4.7	5.0	5.6	6.3
	SDT	104.6	113.5	118.0	122.4	131.0	139.6
30	TC	49.1	46.3	44.9	43.4	40.2	36.7
	kW	4.0	4.5	4.8	5.1	5.7	6.4
	SDT	106.5	115.3	119.7	124.0	132.5	141.0
35	TC	53.7	50.7	49.1	47.5	44.0	40.2
	kW	4.1	4.6	4.9	5.2	5.8	6.5
	SDT	108.5	117.1	121.4	125.7	134.1	142.4
40	TC	58.6	55.3	53.5	51.7	47.9	43.8
	kW	4.2	4.7	5.0	5.3	5.9	6.6
	SDT	110.6	119.0	123.3	127.4	135.7	143.9
45	TC	63.7	60.0	58.1	56.1	51.9	47.4
	kW	4.3	4.8	5.1	5.4	6.0	6.7
	SDT	112.7	121.1	125.2	129.3	137.4	145.4
50	TC	69.0	64.9	62.8	60.6	56.0	50.3
	kW	4.4	4.9	5.2	5.5	6.1	6.8
	SDT	115.0	123.2	127.2	131.2	139.2	146.6

38AXDT14 Total Unit — Condenser Only Ratings — 60 Hz

SST (°F)		Air Temperature Entering Condenser (°F)					
		85	95	100	105	115	125
20	TC	89.2	84.3	81.7	79.0	73.3	67.2
	kW	7.6	8.7	9.2	9.8	11.2	12.7
	SDT	99.4	108.8	113.5	118.1	127.3	136.5
25	TC	98.5	93.1	90.2	87.3	81.1	74.4
	kW	7.7	8.8	9.3	9.9	11.3	12.8
	SDT	100.7	110.0	114.7	119.3	128.4	137.5
30	TC	108.4	102.4	99.4	96.2	89.4	82.1
	kW	7.9	8.9	9.4	10.1	11.4	13.0
	SDT	102.1	111.4	116.0	120.5	129.6	138.7
35	TC	118.9	112.4	109.0	105.5	98.1	90.2
	kW	8.0	9.0	9.6	10.2	11.6	13.1
	SDT	103.6	112.8	117.3	121.9	130.9	139.9
40	TC	130.2	123.0	119.3	115.4	107.4	98.7
	kW	8.1	9.2	9.7	10.3	11.7	13.3
	SDT	105.1	114.3	118.8	123.4	132.4	141.3
45	TC	142.1	134.2	130.1	125.8	117.0	107.6
	kW	8.3	9.3	9.9	10.5	11.9	13.5
	SDT	106.9	116.0	120.5	124.9	133.9	142.7
50	TC	154.6	145.9	141.5	136.8	127.1	116.8
	kW	8.4	9.5	10.1	10.7	12.1	13.6
	SDT	108.7	117.7	122.2	126.6	135.4	144.1

LEGEND

kW — Compressor Motor Power Input
SDT — Saturated Discharge Temperature (°F)
SST — Saturated Suction Temperature
TC — Total Capacity (1000 Btuh) gross

38AXDT14 Circuit A Unit — Condenser Only Ratings — 60 Hz

SST (°F)		Air Temperature Entering Condenser (°F)					
		85	95	100	105	115	125
20	TC	43.8	41.4	40.2	38.9	36.2	33.3
	kW	3.8	4.3	4.5	4.8	5.4	6.2
	SDT	101.2	110.5	115.2	119.8	129.0	138.1
25	TC	48.4	45.8	44.4	43.0	40.0	36.9
	kW	3.9	4.3	4.6	4.9	5.5	6.2
	SDT	102.6	111.9	116.5	121.1	130.2	139.3
30	TC	53.4	50.4	48.9	47.4	44.1	40.7
	kW	3.9	4.4	4.7	5.0	5.6	6.3
	SDT	104.1	113.4	117.9	122.5	131.5	140.6
35	TC	58.6	55.4	53.8	52.1	48.5	44.7
	kW	4.0	4.5	4.8	5.0	5.7	6.4
	SDT	105.8	114.9	119.4	123.9	133.0	142.0
40	TC	64.2	60.7	58.9	57.0	53.1	48.9
	kW	4.1	4.6	4.8	5.1	5.8	6.5
	SDT	107.5	116.6	121.1	125.6	134.6	143.6
45	TC	70.2	66.3	64.3	62.2	57.9	53.4
	kW	4.1	4.7	4.9	5.2	5.9	6.6
	SDT	109.4	118.4	122.9	127.3	136.2	145.1
50	TC	76.4	72.2	70.0	67.7	63.0	58.0
	kW	4.2	4.7	5.0	5.3	6.0	6.7
	SDT	111.4	120.3	124.7	129.2	138.0	146.5

38AXDT14 Circuit B Unit — Condenser Only Ratings — 60 Hz

SST (°F)		Air Temperature Entering Condenser (°F)					
		85	95	100	105	115	125
20	TC	45.4	42.9	41.5	40.1	37.1	33.8
	kW	3.8	4.4	4.7	5.0	5.7	6.6
	SDT	97.7	107.1	111.8	116.4	125.7	134.8
25	TC	50.1	47.3	45.8	44.3	41.1	37.5
	kW	3.9	4.4	4.7	5.0	5.8	6.6
	SDT	98.8	108.2	112.9	117.5	126.7	135.7
30	TC	55.0	52.0	50.4	48.8	45.2	41.4
	kW	3.9	4.5	4.8	5.1	5.8	6.6
	SDT	100.1	109.4	114.0	118.6	127.7	136.7
35	TC	60.3	57.0	55.3	53.5	49.7	45.5
	kW	4.0	4.5	4.8	5.2	5.9	6.7
	SDT	101.4	110.7	115.2	119.8	128.9	137.9
40	TC	65.9	62.3	60.4	58.4	54.3	49.8
	kW	4.0	4.6	4.9	5.2	5.9	6.8
	SDT	102.8	112.0	116.6	121.1	130.2	139.0
45	TC	71.9	67.9	65.8	63.6	59.1	54.2
	kW	4.1	4.7	5.0	5.3	6.0	6.8
	SDT	104.4	113.5	118.0	122.6	131.5	140.3
50	TC	78.2	73.7	71.5	69.1	64.2	58.8
	kW	4.2	4.8	5.1	5.4	6.1	6.9
	SDT	106.0	115.1	119.6	124.1	132.9	141.6

LEGEND

- kW** — Compressor Motor Power Input
- SDT** — Saturated Discharge Temperature (°F)
- SST** — Saturated Suction Temperature
- TC** — Total Capacity (1000 Btuh) gross

38AXZ16 Total Unit — Condenser Only Ratings — 60 Hz

SST (°F)		Air Temperature Entering Condenser (°F)					
		80	85	95	105	115	125
20	TC	121.4	114.4	110.8	107.0	99.2	91.0
	kW	11.3	12.7	13.4	14.2	15.9	17.9
	SDT	101.8	110.9	115.4	120.0	128.9	137.8
25	TC	134.2	126.7	122.7	118.6	110.2	101.2
	kW	11.5	12.9	13.7	14.5	16.2	18.2
	SDT	103.5	112.6	117.1	121.5	130.4	139.2
30	TC	148.0	139.7	135.4	131.0	121.8	112.0
	kW	11.8	13.2	14.0	14.8	16.5	18.5
	SDT	105.4	114.4	118.8	123.2	132.1	140.8
35	TC	162.7	153.6	148.8	144.0	134.0	123.4
	kW	12.0	13.5	14.3	15.1	16.8	18.8
	SDT	107.4	116.3	120.7	125.1	133.8	142.4
40	TC	178.2	168.2	163.1	157.8	146.9	135.4
	kW	12.3	13.8	14.6	15.4	17.2	19.1
	SDT	109.6	118.4	122.7	127.0	135.6	144.0
45	TC	194.6	183.7	178.1	172.3	160.4	147.9
	kW	12.6	14.1	14.9	15.8	17.5	19.5
	SDT	111.9	120.5	124.7	129.0	137.4	145.7
50	TC	212.0	200.0	193.8	187.5	174.5	161.0
	kW	13.0	14.5	15.3	16.1	17.9	19.8
	SDT	114.2	122.7	126.9	131.1	139.4	147.4

38AXZ25 Total Unit — Condenser Only Ratings — 60 Hz

SST (°F)		Air Temperature Entering Condenser (°F)					
		80	85	95	105	115	125
20	TC	157.3	149.3	145.2	140.9	131.9	122.2
	kW	13.4	15.0	15.9	16.8	19.0	21.6
	SDT	102.0	111.1	115.7	120.2	129.3	138.2
25	TC	173.5	164.7	160.0	155.2	145.1	134.5
	kW	13.8	15.4	16.3	17.2	19.4	22.1
	SDT	103.8	112.8	117.3	121.8	130.7	139.9
30	TC	190.9	181.0	175.8	170.4	159.3	147.6
	kW	14.1	15.7	16.6	17.6	19.8	22.3
	SDT	105.7	114.6	119.0	123.4	132.2	140.9
35	TC	209.4	198.4	192.7	186.7	174.5	161.7
	kW	14.4	16.1	17.0	18.0	20.1	22.6
	SDT	107.7	116.5	120.8	125.2	133.8	142.4
40	TC	229.2	217.0	210.7	204.2	190.8	176.7
	kW	14.8	16.5	17.4	18.4	20.5	23.0
	SDT	109.9	118.5	122.8	127.1	135.6	144.0
45	TC	250.3	236.8	229.9	222.8	208.1	192.7
	kW	15.1	16.9	17.8	18.8	21.0	23.4
	SDT	112.2	120.7	124.9	129.1	137.4	145.7
50	TC	272.7	257.9	250.3	242.5	226.4	209.6
	kW	15.6	17.3	18.3	19.3	21.4	23.8
	SDT	114.6	123.0	127.1	131.3	139.5	147.5

LEGEND

kW — Compressor Motor Power Input
SDT — Saturated Discharge Temperature (°F)
SST — Saturated Suction Temperature
TC — Total Capacity (1000 Btuh) gross

38AXDT16 Total Unit — Condenser Only Ratings — 60 Hz

SST (°F)		Air Temperature Entering Condenser (°F)					
		85	95	100	105	115	125
20	TC	121.1	114.5	111.0	107.4	99.8	91.6
	kW	11.7	13.3	14.1	15.0	17.1	19.3
	SDT	105.6	115.5	120.4	125.3	135.1	144.9
25	TC	134.1	126.8	123.0	119.0	110.8	101.9
	kW	11.7	13.3	14.1	15.0	17.0	19.3
	SDT	105.7	115.6	120.5	125.4	135.2	144.9
30	TC	148.0	140.0	135.8	131.5	122.5	112.9
	kW	11.7	13.3	14.1	15.0	17.0	19.3
	SDT	106.1	115.8	120.7	125.6	135.3	145.1
35	TC	162.5	153.8	149.3	144.6	134.9	124.6
	kW	11.8	13.4	14.2	15.1	17.1	19.3
	SDT	106.8	116.4	121.2	126.0	135.6	145.3
40	TC	177.7	168.2	163.3	158.3	147.8	136.7
	kW	12.0	13.5	14.3	15.2	17.2	19.3
	SDT	108.1	117.5	122.2	126.9	136.3	145.8
45	TC	193.5	183.1	177.8	172.4	161.1	149.3
	kW	12.2	13.7	14.5	15.4	17.3	19.5
	SDT	109.7	118.9	123.5	128.1	137.4	146.6
50	TC	210.0	198.7	192.9	187.0	174.8	162.1
	kW	12.4	14.0	14.8	15.7	17.6	19.7
	SDT	111.5	120.6	125.1	129.7	138.7	147.7

38AXDT16 Circuit A — Condenser Only Ratings — 60 Hz

SST (°F)		Air Temperature Entering Condenser (°F)					
		85	95	100	105	115	125
20	TC	60.6	57.5	55.9	54.2	50.7	46.9
	kW	5.8	6.6	7.0	7.5	8.4	9.6
	SDT	105.7	115.5	120.4	125.4	135.2	144.9
25	TC	66.9	63.5	61.7	59.8	55.9	51.6
	kW	5.8	6.6	7.0	7.5	8.4	9.6
	SDT	105.8	115.6	120.5	125.4	135.2	145.0
30	TC	73.7	69.9	67.9	65.8	61.4	56.8
	kW	5.8	6.6	7.0	7.4	8.4	9.6
	SDT	106.1	115.8	120.7	125.6	135.4	145.1
35	TC	80.9	76.7	74.5	72.2	67.4	62.3
	kW	5.9	6.6	7.0	7.5	8.4	9.5
	SDT	106.7	116.3	121.1	126.0	135.6	145.3
40	TC	88.4	83.8	81.3	78.8	73.6	68.1
	kW	5.9	6.7	7.1	7.5	8.5	9.6
	SDT	107.8	117.3	122.0	126.7	136.2	145.6
45	TC	96.3	91.1	88.5	85.8	80.1	74.1
	kW	6.0	6.8	7.2	7.6	8.6	9.6
	SDT	109.4	118.6	123.2	127.9	137.1	146.3
50	TC	104.5	98.9	96.0	93.0	86.8	80.3
	kW	6.2	6.9	7.3	7.7	8.7	9.7
	SDT	111.1	120.2	124.8	129.3	138.4	147.3

LEGEND

kW — Compressor Motor Power Input
SDT — Saturated Discharge Temperature (°F)
SST — Saturated Suction Temperature
TC — Total Capacity (1000 Btuh) gross

38AXDT16 Circuit B — Condenser Only Ratings — 60 Hz

SST (°F)		Air Temperature Entering Condenser (°F)					
		85	95	100	105	115	125
20	TC	60.5	56.9	55.1	53.1	49.1	44.8
	kW	5.9	6.7	7.1	7.6	8.6	9.8
	SDT	105.5	115.4	120.3	125.2	135.1	144.8
25	TC	67.2	63.3	61.3	59.2	54.9	50.3
	kW	5.9	6.7	7.1	7.6	8.6	9.7
	SDT	105.7	115.5	120.4	125.3	135.1	144.9
30	TC	74.3	70.1	67.9	65.7	61.1	56.2
	kW	5.9	6.7	7.1	7.6	8.6	9.7
	SDT	106.1	115.8	120.7	125.5	135.3	145.0
35	TC	81.6	77.2	74.8	72.5	67.5	62.3
	kW	6.0	6.8	7.2	7.6	8.6	9.7
	SDT	106.9	116.5	121.3	126.1	135.7	145.3
40	TC	89.2	84.4	82.0	79.4	74.2	68.7
	kW	6.1	6.8	7.3	7.7	8.7	9.8
	SDT	108.3	117.7	122.4	127.1	136.5	145.9
45	TC	97.2	92.0	89.3	86.6	81.0	75.2
	kW	6.2	6.9	7.4	7.8	8.8	9.9
	SDT	110.0	119.2	123.8	128.4	137.6	146.8
50	TC	105.5	99.9	97.0	94.1	88.0	81.8
	kW	6.3	7.1	7.5	7.9	8.9	10.0
	SDT	111.8	121.0	125.5	130.0	139.1	148.0

38AXDT25 Total Unit — Condenser Only Ratings — 60 Hz

SST (°F)		Air Temperature Entering Condenser (°F)					
		85	95	100	105	115	125
20	TC	159.6	151.4	147.2	142.8	133.6	123.7
	kW	14.4	16.2	17.1	18.2	20.5	23.2
	SDT	107.0	116.4	121.1	125.8	135.3	144.6
25	TC	176.0	166.9	162.1	157.2	147.0	136.1
	kW	14.9	16.6	17.6	18.7	21.0	23.7
	SDT	109.1	118.4	123.1	127.7	137.0	146.1
30	TC	193.7	183.5	178.2	172.8	161.4	149.5
	kW	15.3	17.1	18.1	19.2	21.5	24.2
	SDT	111.3	120.5	125.1	129.6	138.8	147.7
35	TC	212.6	201.4	195.5	189.5	177.0	164.0
	kW	15.7	17.6	18.6	19.7	22.1	24.7
	SDT	113.5	122.5	127.1	131.6	140.7	149.3
40	TC	233.0	220.6	214.2	207.6	193.9	179.7
	kW	16.2	18.1	19.1	20.2	22.6	25.2
	SDT	115.8	124.7	129.2	133.7	142.6	151.1
45	TC	254.9	241.3	234.2	227.0	212.0	196.6
	kW	16.7	18.6	19.6	20.8	23.2	25.7
	SDT	118.2	127.0	131.5	135.9	144.6	152.9
50	TC	278.5	263.6	255.8	247.9	231.6	214.7
	kW	17.2	19.1	20.2	21.3	23.7	26.3
	SDT	120.7	129.5	133.8	138.2	146.7	154.7

LEGEND

kW — Compressor Motor Power Input
SDT — Saturated Discharge Temperature (°F)
SST — Saturated Suction Temperature
TC — Total Capacity (1000 Btuh) gross

38AXDT25 Circuit A — Condenser Only Ratings — 60 Hz

SST (°F)		Air Temperature Entering Condenser (°F)					
		85	95	100	105	115	125
20	TC	78.7	74.7	72.6	70.4	65.9	61.2
	kW	7.4	8.2	8.7	9.2	10.3	11.5
	SDT	109.4	118.9	123.6	128.4	137.9	147.2
25	TC	86.8	82.3	79.9	77.5	72.5	67.2
	kW	7.6	8.5	9.0	9.5	10.6	11.8
	SDT	111.6	121.0	125.7	130.4	139.7	148.7
30	TC	95.4	90.5	87.9	85.2	79.7	73.8
	kW	7.9	8.8	9.3	9.8	10.9	12.1
	SDT	113.9	123.2	127.8	132.4	141.6	150.3
35	TC	104.8	99.3	96.5	93.5	87.4	81.0
	kW	8.1	9.0	9.5	10.1	11.3	12.5
	SDT	116.2	125.3	129.9	134.4	143.6	152.0
40	TC	115.0	108.9	105.8	102.5	95.8	88.8
	kW	8.4	9.3	9.8	10.4	11.6	12.8
	SDT	118.6	127.6	132.1	136.6	145.5	153.7
45	TC	125.9	119.3	115.8	112.2	104.8	97.1
	kW	8.6	9.6	10.1	10.7	11.9	13.1
	SDT	121.1	129.9	134.4	138.8	147.5	155.5
50	TC	137.7	130.4	126.6	122.6	114.5	106.2
	kW	8.9	9.9	10.4	11.0	12.1	13.4
	SDT	123.7	132.4	136.8	141.2	149.5	157.3

38AXDT25 Circuit B — Condenser Only Ratings — 60 Hz

SST (°F)		Air Temperature Entering Condenser (°F)					
		85	95	100	105	115	125
20	TC	80.9	76.8	74.6	72.4	67.6	62.6
	kW	7.1	7.9	8.4	8.9	10.2	11.7
	SDT	104.5	114.0	118.6	123.3	132.6	141.9
25	TC	89.3	84.6	82.2	79.7	74.4	68.9
	kW	7.2	8.1	8.6	9.2	10.4	11.8
	SDT	106.5	115.8	120.5	125.1	134.3	143.5
30	TC	98.2	93.0	90.3	87.5	81.7	75.6
	kW	7.4	8.3	8.8	9.4	10.6	12.0
	SDT	108.6	117.8	122.3	126.9	136.0	145.0
35	TC	107.8	102.0	99.0	96.0	89.6	83.0
	kW	7.6	8.6	9.1	9.6	10.8	12.2
	SDT	110.7	119.8	124.3	128.8	137.8	146.7
40	TC	118.0	111.7	108.4	105.0	98.1	90.9
	kW	7.8	8.8	9.3	9.8	11.1	12.4
	SDT	112.9	121.9	126.4	130.8	139.7	148.4
45	TC	129.0	122.0	118.5	114.8	107.2	99.4
	kW	8.0	9.0	9.5	10.1	11.3	12.7
	SDT	115.3	124.1	128.6	133.0	141.8	150.3
50	TC	140.8	133.2	129.3	125.3	117.0	108.6
	kW	8.3	9.2	9.8	10.3	11.6	12.9
	SDT	117.8	126.5	130.9	135.3	144.0	152.2

LEGEND

kW — Compressor Motor Power Input
SDT — Saturated Discharge Temperature (°F)
SST — Saturated Suction Temperature
TC — Total Capacity (1000 Btuh) gross

38AXDT28 Total Unit — Condenser Only Ratings — 60 Hz

SST (°F)		Air Temperature Entering Condenser (°F)					
		85	95	100	105	115	125
20	TC	190.9	178.2	170.8	162.8	144.0	121.7
	kW	16.9	19.1	20.2	21.5	24.3	27.6
	SDT	103.8	113.1	117.8	122.4	131.9	141.5
25	TC	210.8	197.8	190.5	182.6	164.7	143.3
	kW	17.2	19.3	20.5	21.7	24.4	27.6
	SDT	104.9	114.1	118.6	123.2	132.4	141.8
30	TC	231.6	218.0	210.5	202.5	184.8	164.3
	kW	17.5	19.6	20.8	22.0	24.7	27.8
	SDT	106.1	115.2	119.7	124.2	133.2	142.2
35	TC	253.5	239.2	231.4	223.1	205.0	184.7
	kW	17.8	20.0	21.1	22.4	25.1	28.1
	SDT	107.5	116.5	120.9	125.4	134.3	143.1
40	TC	276.3	261.1	252.9	244.3	225.7	205.0
	kW	18.3	20.4	21.5	22.8	25.4	28.4
	SDT	109.3	118.1	122.4	126.8	135.5	144.2
45	TC	300.1	283.7	275.0	266.0	246.6	225.6
	kW	18.8	20.9	22.0	23.3	25.9	28.9
	SDT	111.5	120.1	124.4	128.7	137.1	145.5
50	TC	325.0	307.2	297.9	288.2	267.9	246.1
	kW	19.3	21.4	22.6	23.8	26.5	29.4
	SDT	113.8	122.3	126.5	130.7	139.0	147.1

38AXDT28 Circuit A — Condenser Only Ratings — 60 Hz

SST (°F)		Air Temperature Entering Condenser (°F)					
		85	95	100	105	115	125
20	TC	89.8	85.3	83.0	80.6	75.5	70.2
	kW	7.4	8.3	8.8	9.3	10.4	11.7
	SDT	103.1	112.8	117.7	122.5	132.3	142.0
25	TC	99.1	94.1	91.5	88.9	83.3	77.3
	kW	7.5	8.4	8.9	9.4	10.5	11.8
	SDT	103.7	113.2	118.1	122.9	132.5	142.1
30	TC	109.2	103.7	100.8	97.9	91.7	85.1
	kW	7.6	8.5	9.0	9.5	10.6	11.9
	SDT	104.3	113.8	118.5	123.3	132.8	142.4
35	TC	120.0	114.0	110.8	107.6	100.8	93.6
	kW	7.7	8.6	9.1	9.6	10.7	12.0
	SDT	105.0	114.3	119.0	123.8	133.2	142.7
40	TC	131.3	124.8	121.4	117.9	110.6	102.7
	kW	7.9	8.7	9.2	9.7	10.8	12.1
	SDT	106.5	115.5	120.0	124.5	133.7	143.1
45	TC	143.1	135.9	132.2	128.5	120.6	112.3
	kW	8.1	8.9	9.4	9.9	11.0	12.3
	SDT	108.5	117.4	121.8	126.2	135.0	143.8
50	TC	155.7	147.7	143.6	139.5	130.9	122.1
	kW	8.3	9.2	9.7	10.2	11.3	12.5
	SDT	110.8	119.5	123.8	128.2	136.7	145.2

LEGEND

kW — Compressor Motor Power Input
SDT — Saturated Discharge Temperature (°F)
SST — Saturated Suction Temperature
TC — Total Capacity (1000 Btuh) gross

38AXDT28 Circuit B — Condenser Only Ratings — 60 Hz

SST (°F)		Air Temperature Entering Condenser (°F)					
		85	95	100	105	115	125
20	TC	101.1	92.9	87.9	82.2	68.5	51.5
	kW	9.5	10.8	11.5	12.2	13.9	15.8
	SDT	104.5	113.4	117.8	122.4	131.6	141.1
25	TC	111.6	103.6	98.9	93.7	81.4	66.0
	kW	9.7	11.0	11.6	12.3	13.9	15.8
	SDT	106.1	114.9	119.2	123.6	132.3	141.4
30	TC	122.4	114.4	109.7	104.7	93.1	79.2
	kW	9.9	11.2	11.8	12.5	14.1	15.8
	SDT	108.0	116.7	121.0	125.2	133.6	142.1
35	TC	133.5	125.2	120.6	115.5	104.2	91.1
	kW	10.2	11.4	12.1	12.8	14.3	16.0
	SDT	110.0	118.6	122.8	127.0	135.3	143.5
40	TC	145.0	136.3	131.5	126.4	115.1	102.3
	kW	10.4	11.7	12.3	13.1	14.6	16.3
	SDT	112.1	120.7	124.8	129.0	137.2	145.2
45	TC	156.9	147.7	142.8	137.5	126.0	113.3
	kW	10.7	11.9	12.6	13.4	14.9	16.6
	SDT	114.4	122.8	127.0	131.1	139.2	147.1
50	TC	169.4	159.5	154.3	148.8	136.9	124.1
	kW	10.9	12.2	12.9	13.7	15.3	17.0
	SDT	116.9	125.1	129.2	133.3	141.3	149.1

LEGEND

kW — Compressor Motor Power Input
SDT — Saturated Discharge Temperature (°F)
SST — Saturated Suction Temperature
TC — Total Capacity (1000 Btuh) gross

38AXZ07/40RLA07 Stage 2 Combination Ratings — 60 Hz

38AXZ07/40RLA07			AMBIENT TEMPERATURE (°F)																
			85			95			105			115			125				
			EA (db)			EA (db)			EA (db)			EA (db)			EA (db)				
			75	80	85	75	80	85	75	80	85	75	80	85	75	80	85		
1800 cfm	EA (wb)	58	TC	60.1	60.1	68.6	61.1	61.1	69.0	61.1	61.1	69.0	61.2	61.2	69.0	61.1	61.1	69.0	
			SHC	51.6	60.1	68.6	53.2	61.1	69.0	53.2	61.1	69.0	53.3	61.2	69.0	53.3	61.1	69.0	
		62	TC	63.9	63.9	65.8	63.9	63.9	65.8	63.9	63.9	65.8	63.9	63.9	65.8	63.9	63.9	65.8	
			SHC	48.2	57.0	65.8	48.2	57.0	65.8	48.2	57.0	65.8	48.2	57.0	65.8	48.2	57.0	65.8	
		67	TC	70.0	70.0	70.0	70.0	70.0	70.0	70.0	70.0	70.0	70.0	70.0	70.0	70.0	70.0	70.0	
			SHC	39.3	48.0	56.6	39.3	48.0	56.6	39.3	48.0	56.6	39.3	48.0	56.6	39.3	48.0	56.7	
	72	TC	76.5	76.5	76.5	76.5	76.5	76.5	76.5	76.5	76.5	76.5	76.5	76.5	76.5	76.5	76.5		
		SHC	30.6	38.8	47.1	30.6	38.8	47.1	30.6	38.8	47.1	30.6	38.8	47.1	30.6	38.8	47.1		
	76	TC	—	82.3	82.3	—	82.3	82.3	—	82.3	82.3	—	82.3	82.3	—	82.3	82.3		
		SHC	—	31.1	41.0	—	31.1	41.0	—	31.1	41.0	—	31.1	41.0	—	31.1	41.0		
	2100 cfm	EA (wb)	58	TC	64.1	64.1	72.4	64.1	64.1	72.4	64.1	64.1	72.4	64.2	64.2	72.4	64.1	64.1	72.4
				SHC	55.9	64.1	72.4	55.9	64.1	72.4	55.9	64.1	72.4	55.9	64.2	72.4	55.9	64.1	72.4
62			TC	65.6	65.6	71.7	65.6	65.6	71.7	65.6	65.6	71.7	65.6	65.6	71.7	65.6	65.6	71.6	
			SHC	51.6	61.6	71.7	51.6	61.6	71.7	51.6	61.6	71.7	51.6	61.6	71.7	51.6	61.6	71.6	
67			TC	71.7	71.7	71.7	71.7	71.7	71.7	71.7	71.7	71.7	71.7	71.7	71.7	71.7	71.7	71.7	
			SHC	41.5	51.5	61.5	41.5	51.5	61.5	41.5	51.5	61.5	41.6	51.5	61.5	41.6	51.5	61.5	
72		TC	78.4	78.4	78.4	78.4	78.4	78.4	78.4	78.4	78.4	78.4	78.4	78.4	78.4	78.4	78.4		
		SHC	31.4	41.0	50.6	31.4	41.0	50.6	31.4	41.0	50.6	31.4	41.0	50.6	31.4	41.0	50.6		
76		TC	—	84.0	84.0	—	84.0	84.0	—	84.0	84.0	—	84.0	84.0	—	84.1	84.1		
		SHC	—	32.5	40.1	—	32.5	39.9	—	32.5	39.9	—	32.5	39.9	—	32.5	44.1		
2400 cfm		EA (wb)	58	TC	66.7	66.7	75.2	66.7	66.7	75.2	66.7	66.7	75.2	66.7	66.7	75.3	66.7	66.7	75.3
				SHC	58.1	66.7	75.2	58.1	66.7	75.2	58.1	66.7	75.2	58.1	66.7	75.3	58.1	66.7	75.3
	62		TC	67.3	67.3	76.7	67.3	67.3	76.6	67.3	67.3	76.6	67.3	67.3	76.6	67.3	67.3	76.7	
			SHC	54.6	65.6	76.7	54.6	65.6	76.6	54.6	65.6	76.6	54.6	65.6	76.6	54.6	65.6	76.7	
	67		TC	73.1	73.1	73.1	73.1	73.1	73.1	73.1	73.1	73.1	73.1	73.1	73.1	73.1	73.1	73.1	
			SHC	43.6	54.9	66.2	43.6	54.9	66.2	43.6	54.9	66.2	43.6	54.9	66.2	43.6	54.9	66.2	
	72	TC	79.8	79.8	79.8	79.8	79.8	79.8	79.8	79.8	79.8	79.8	79.8	79.8	79.8	79.8	79.8		
		SHC	32.1	43.0	54.0	32.1	43.0	54.0	32.1	43.0	54.0	32.1	43.0	54.0	32.1	43.0	54.0		
	76	TC	—	85.5	85.5	—	85.5	85.5	—	85.5	85.5	—	85.5	85.5	—	85.5	85.5		
		SHC	—	33.6	43.5	—	33.6	43.5	—	33.6	43.5	—	33.6	43.5	—	33.6	43.5		
	2700 cfm	EA (wb)	58	TC	68.8	68.8	77.6	68.8	68.8	77.6	68.8	68.8	77.6	68.7	68.7	77.6	68.8	68.8	77.6
				SHC	59.9	68.8	77.6	59.9	68.8	77.6	59.9	68.8	77.6	59.9	68.7	77.6	59.9	68.8	77.6
62			TC	69.0	69.0	80.1	69.0	69.0	80.1	68.9	68.9	80.5	69.5	69.5	79.0	69.8	69.8	79.0	
			SHC	56.8	68.4	80.1	56.8	68.4	80.1	56.9	68.7	80.5	56.3	67.6	79.0	56.4	67.7	79.0	
67			TC	74.2	74.2	74.2	74.2	74.2	74.2	74.2	74.2	74.2	74.1	74.1	74.1	74.2	74.2	74.2	
			SHC	45.7	58.2	70.8	45.7	58.2	70.8	45.7	58.2	70.8	45.7	58.2	70.8	45.7	58.2	70.8	
72		TC	81.0	81.0	81.0	81.0	81.0	81.0	81.0	81.0	81.0	80.9	80.9	80.9	81.0	81.0	81.0		
		SHC	32.8	45.0	57.2	32.8	45.0	57.2	32.8	45.0	57.2	32.8	45.0	57.2	32.8	45.0	57.2		
76		TC	—	86.6	86.6	—	86.6	86.6	—	86.6	86.6	—	86.6	86.6	—	86.6	86.6		
		SHC	—	34.5	45.8	—	34.5	45.8	—	34.5	45.8	—	34.5	45.8	—	34.5	45.9		
3000 cfm		EA (wb)	58	TC	70.6	70.6	79.7	70.5	70.5	79.6	70.6	70.6	79.6	70.6	70.6	79.7	70.6	70.6	79.7
				SHC	61.5	70.6	79.7	61.5	70.5	79.6	61.5	70.6	79.6	61.5	70.6	79.7	61.5	70.6	79.7
	62		TC	70.6	70.6	82.7	70.6	70.6	82.8	70.6	70.6	82.7	72.3	72.3	79.6	71.7	71.7	79.5	
			SHC	58.5	70.6	82.7	58.5	70.6	82.8	58.5	70.6	82.7	57.1	68.4	79.6	57.0	68.3	79.5	
	67		TC	75.0	75.0	75.2	75.0	75.0	75.2	75.0	75.0	75.2	75.0	75.0	75.2	75.0	75.0	75.2	
			SHC	47.6	61.4	75.2	47.6	61.4	75.2	47.6	61.4	75.2	47.6	61.4	75.2	47.6	61.4	75.2	
	72	TC	81.9	81.9	81.9	81.9	81.9	81.9	81.9	81.9	81.9	81.9	81.9	81.9	81.9	81.9	81.9		
		SHC	33.4	46.8	60.3	33.4	46.8	60.2	33.4	46.8	60.3	33.4	46.8	60.2	33.4	46.8	60.3		
	76	TC	—	87.5	87.5	—	87.5	87.5	—	87.5	87.5	—	87.5	87.5	—	87.5	87.5		
		SHC	—	35.3	48.0	—	35.3	48.0	—	35.3	48.0	—	35.3	48.0	—	35.3	48.0		

LEGEND

- db — dry bulb
- EA — Entering Air Temperature (°F)
- SHC — Sensible Heat Capacity (1000 Btuh) gross
- TC — Total Capacity (1000 Btuh) gross
- wb — wet bulb

38AXZ07/40RLA07 Stage 1 Combination Ratings — 60 Hz

38AXZ07/40RLA07			AMBIENT TEMPERATURE (°F)															
			85			95			105			115			125			
			EA (db)			EA (db)			EA (db)			EA (db)			EA (db)			
			75	80	85	75	80	85	75	80	85	75	80	85	75	80	85	
1500 cfm	EA (wb)	58	TC	49.9	49.9	56.4	49.9	49.9	56.4	49.9	49.9	56.4	49.9	49.9	56.4	49.9	49.9	56.4
			SHC	43.5	49.9	56.4	43.5	49.9	56.4	43.5	49.9	56.4	43.5	49.9	56.4	43.5	49.9	56.4
		62	TC	51.5	51.5	55.8	50.1	50.1	52.9	51.5	51.5	55.8	51.5	51.5	55.8	51.5	51.5	55.8
			SHC	40.2	48.0	55.8	38.4	45.6	52.9	40.2	48.0	55.8	40.2	48.0	55.8	40.2	48.0	55.8
		67	TC	55.4	55.4	55.4	55.3	55.3	55.3	55.3	55.3	55.3	55.3	55.3	55.3	55.3	55.3	55.3
			SHC	31.5	38.7	46.0	31.5	38.7	45.9	31.5	38.7	45.9	31.5	38.7	45.9	31.5	38.7	45.9
		72	TC	62.9	62.9	62.9	62.9	62.9	62.9	62.9	62.9	62.9	62.9	62.9	62.9	62.9	62.9	62.9
			SHC	25.3	33.2	41.1	25.3	33.2	41.1	25.3	33.2	41.1	25.3	33.2	41.1	25.3	33.2	41.1
		76	TC	—	66.5	66.5	—	66.5	66.5	—	66.4	66.4	—	66.5	66.5	—	66.4	66.4
			SHC	—	25.7	34.0	—	25.7	34.0	—	25.7	34.0	—	25.7	34.0	—	25.7	34.0
1800 cfm	EA (wb)	58	TC	53.0	53.0	59.9	53.0	53.0	59.9	53.1	53.1	59.9	53.0	53.0	59.9	53.0	53.0	59.9
			SHC	46.2	53.0	59.9	46.2	53.0	59.9	46.2	53.1	59.9	46.2	53.0	59.9	46.2	53.0	59.9
		62	TC	53.6	53.6	61.9	53.6	53.6	61.9	53.6	53.6	61.9	53.6	53.6	61.9	53.6	53.6	61.9
			SHC	43.9	52.9	61.9	43.9	52.9	61.9	43.9	52.9	61.9	43.9	52.9	61.9	43.9	52.9	61.9
		67	TC	57.9	57.9	57.9	57.9	57.9	57.9	58.7	58.7	58.7	57.9	57.9	57.9	58.7	58.7	58.7
			SHC	34.4	43.3	52.1	34.5	43.3	52.2	35.4	44.7	54.0	34.5	43.3	52.2	35.4	44.7	54.0
		72	TC	63.8	63.8	63.8	63.7	63.7	63.7	63.7	63.7	63.7	63.7	63.7	63.7	63.8	63.8	63.8
			SHC	25.7	34.3	42.8	25.7	34.3	42.8	25.7	34.3	42.8	25.7	34.3	42.8	25.7	34.2	42.7
		76	TC	—	69.6	69.6	—	69.6	69.6	—	70.0	70.0	—	70.0	70.0	—	69.6	69.6
			SHC	—	27.6	35.7	—	27.6	35.7	—	28.4	37.9	—	28.4	37.8	—	27.6	35.7
2100 cfm	EA (wb)	58	TC	55.6	55.6	62.8	55.6	55.6	62.8	55.6	55.6	62.8	55.6	55.6	62.8	55.6	55.6	62.8
			SHC	48.4	55.6	62.8	48.4	55.6	62.8	48.4	55.6	62.8	48.4	55.6	62.8	48.4	55.6	62.8
		62	TC	55.9	55.9	64.4	56.1	56.1	64.2	55.6	55.6	65.2	56.1	56.1	63.9	55.9	55.9	64.5
			SHC	45.7	55.0	64.4	45.6	54.9	64.2	46.0	55.6	65.2	45.5	54.7	63.9	45.7	55.1	64.5
		67	TC	59.6	59.6	59.6	59.6	59.6	59.6	59.6	59.6	59.6	59.6	59.6	59.6	59.6	59.6	59.6
			SHC	37.0	47.4	57.7	37.0	47.4	57.7	37.0	47.4	57.7	37.1	47.4	57.7	37.1	47.4	57.7
		72	TC	65.7	65.7	65.7	65.7	65.7	65.7	65.7	65.7	65.7	66.3	66.3	66.3	65.7	65.7	65.7
			SHC	26.8	36.9	47.0	26.8	36.9	47.0	26.8	36.9	47.0	27.3	38.0	48.7	26.8	36.9	47.0
		76	TC	—	70.7	70.7	—	70.9	70.9	—	70.8	70.8	—	70.9	70.9	—	70.9	70.9
			SHC	—	28.4	37.8	—	28.5	38.0	—	28.4	37.7	—	28.5	38.0	—	28.5	38.0
2400 cfm	EA (wb)	58	TC	57.7	57.7	65.1	57.7	57.7	65.2	57.7	57.7	65.1	57.7	57.7	65.1	57.7	57.7	65.1
			SHC	50.3	57.7	65.1	50.3	57.7	65.2	50.3	57.7	65.1	50.2	57.7	65.1	50.2	57.7	65.1
		62	TC	56.1	56.1	67.2	57.7	57.7	67.7	57.1	57.1	67.0	57.0	57.0	66.9	57.0	57.0	66.9
			SHC	44.9	56.1	67.2	47.8	57.7	67.7	47.3	57.1	67.0	47.2	57.0	66.9	47.2	57.0	66.9
		67	TC	60.8	60.8	63.0	60.8	60.8	63.0	60.8	60.8	63.0	60.8	60.8	63.0	60.8	60.8	63.0
			SHC	39.4	51.2	63.0	39.4	51.2	63.0	39.4	51.2	63.0	39.4	51.2	63.0	39.4	51.2	63.0
		72	TC	67.0	67.0	67.0	67.0	67.0	67.0	67.0	67.0	67.0	67.0	67.0	67.0	67.0	67.0	67.0
			SHC	27.7	39.2	50.7	27.7	39.2	50.7	27.7	39.2	50.7	27.7	39.2	50.6	27.7	39.2	50.7
		76	TC	—	72.3	72.3	—	72.3	72.3	—	72.3	72.3	—	72.5	72.5	—	72.3	72.3
			SHC	—	29.7	40.7	—	29.7	40.7	—	29.7	40.7	—	29.7	40.7	—	29.7	40.7
2700 cfm	EA (wb)	58	TC	58.9	58.9	66.5	59.0	59.0	66.6	59.1	59.1	66.7	59.1	59.1	66.7	59.1	59.1	66.7
			SHC	51.3	58.9	66.5	51.4	59.0	66.6	51.4	59.1	66.7	51.4	59.1	66.7	51.4	59.1	66.7
		62	TC	58.9	58.9	69.1	59.1	59.1	69.3	59.2	59.2	69.4	59.2	59.2	69.3	59.2	59.2	69.3
			SHC	48.8	58.9	69.1	48.9	59.1	69.3	49.0	59.2	69.4	49.0	59.2	69.3	49.0	59.2	69.3
		67	TC	61.7	61.7	67.6	61.7	61.7	67.6	61.7	61.7	67.7	61.7	61.7	67.7	61.7	61.7	67.6
			SHC	41.6	54.6	67.6	41.6	54.6	67.6	41.6	54.6	67.7	41.6	54.6	67.7	41.6	54.6	67.6
		72	TC	68.0	68.0	68.0	68.0	68.0	68.0	68.0	68.0	68.0	67.9	67.9	67.9	68.0	68.0	68.0
			SHC	28.5	41.4	54.2	28.5	41.4	54.2	28.5	41.4	54.2	28.5	41.3	54.2	28.5	41.4	54.2
		76	TC	—	73.2	73.2	—	73.2	73.2	—	73.2	73.2	—	73.2	73.2	—	73.2	73.2
			SHC	—	30.6	42.9	—	30.6	42.9	—	30.6	42.9	—	30.6	42.9	—	30.6	42.9

LEGEND

- db — dry bulb
- EA — Entering Air Temperature (°F)
- SHC — Sensible Heat Capacity (1000 Btuh) gross
- TC — Total Capacity (1000 Btuh) gross
- wb — wet bulb

38AXZ08/40RLA08 Stage 2 Combination Ratings — 60 Hz

38AXZ08/40RLA08			AMBIENT TEMPERATURE (°F)																
			85			95			105			115			125				
			EA (db)			EA (db)			EA (db)			EA (db)			EA (db)				
			75	80	85	75	80	85	75	80	85	75	80	85	75	80	85		
2250 cfm	EA (wb)	58	TC	80.1	80.1	88.0	74.7	74.7	85.3	70.1	70.1	80.4	65.2	65.2	75.0	59.9	59.9	69.3	
			SHC	67.1	77.6	88.0	64.1	74.7	85.3	59.8	70.1	80.4	55.4	65.2	75.0	50.5	59.9	69.3	
		62	TC	84.0	84.0	84.0	79.6	79.6	80.2	76.5	76.5	76.5	68.1	68.1	72.9	61.7	61.7	69.0	
			SHC	59.4	70.6	81.7	57.1	68.7	80.2	52.4	63.2	74.0	49.9	61.4	72.9	46.0	57.5	69.0	
		67	TC	93.1	93.1	93.1	88.5	88.5	88.5	82.8	82.8	82.8	76.4	76.4	76.4	69.4	69.4	69.4	
			SHC	48.7	59.5	70.4	46.0	57.2	68.5	42.7	54.1	65.4	39.0	50.4	61.8	35.1	46.6	58.0	
	72	TC	103.5	103.5	103.5	98.3	98.3	98.3	92.2	92.2	92.2	85.3	85.3	85.3	77.8	77.8	77.8		
		SHC	38.5	49.0	59.5	35.4	46.2	57.0	31.9	42.9	53.9	28.1	39.2	50.3	24.2	35.4	46.5		
	76	TC	—	112.1	112.1	—	106.7	106.7	—	100.2	100.2	—	92.7	92.7	—	85.1	85.1		
		SHC	—	40.3	52.7	—	36.9	49.3	—	33.7	46.1	—	30.1	39.1	—	26.4	36.6		
	2625 cfm	EA (wb)	58	TC	84.1	84.1	95.6	80.0	80.0	91.2	75.0	75.0	85.8	69.8	69.8	80.1	64.3	64.3	74.1
				SHC	72.6	84.1	95.6	68.7	80.0	91.2	64.2	75.0	85.8	59.4	69.8	80.1	54.4	64.3	74.1
62			TC	88.3	88.3	92.9	82.8	82.8	89.4	77.0	77.0	85.6	70.8	70.8	81.5	64.9	64.9	75.5	
			SHC	66.2	79.6	92.9	62.7	76.0	89.4	59.0	72.3	85.6	55.1	68.3	81.5	50.2	62.9	75.5	
67			TC	97.6	97.6	97.6	92.0	92.0	92.0	85.7	85.7	85.7	78.9	78.9	78.9	71.6	71.6	71.6	
			SHC	53.0	66.0	79.1	49.9	63.1	76.4	46.3	59.5	72.8	42.5	55.8	69.1	38.6	51.9	65.2	
72		TC	108.0	108.0	108.0	102.0	102.0	102.0	95.2	95.2	95.2	87.9	87.9	87.9	80.4	80.4	80.4		
		SHC	40.5	53.1	65.7	37.1	49.9	62.8	33.4	46.3	59.2	29.6	42.5	55.5	25.7	38.7	51.7		
76		TC	—	116.9	116.9	—	110.4	110.4	—	103.3	103.3	—	95.2	95.2	—	87.0	87.0		
		SHC	—	42.5	57.1	—	39.3	49.8	—	35.7	47.3	—	31.9	44.0	—	28.0	40.3		
3000 cfm		EA (wb)	58	TC	88.4	88.4	100.4	83.8	83.8	95.5	78.6	78.6	89.8	73.1	73.1	83.8	67.1	67.1	77.2
				SHC	76.4	88.4	100.4	72.2	83.8	95.5	67.4	78.6	89.8	62.3	73.1	83.8	56.9	67.1	77.2
	62		TC	90.6	90.6	100.1	85.1	85.1	96.6	79.3	79.3	92.2	73.6	73.6	86.4	67.2	67.2	80.7	
			SHC	70.5	85.3	100.1	67.1	81.9	96.6	63.1	77.7	92.2	58.4	72.4	86.4	53.6	67.2	80.7	
	67		TC	100.3	100.3	100.3	94.1	94.1	94.1	87.6	87.6	87.6	80.6	80.6	80.6	73.1	73.1	73.1	
			SHC	56.4	71.2	86.0	52.9	67.8	82.6	49.2	64.1	79.0	45.4	60.3	75.2	41.4	56.3	71.3	
	72	TC	110.8	110.8	110.8	104.2	104.2	104.2	97.1	97.1	97.1	89.6	89.6	89.6	81.7	81.7	81.7		
		SHC	41.9	56.3	70.8	38.3	52.8	67.3	34.6	49.1	63.6	30.7	45.2	59.8	26.7	41.3	55.8		
	76	TC	—	119.9	119.9	—	112.5	112.5	—	104.9	104.9	—	96.9	96.9	—	88.5	88.5		
		SHC	—	44.4	57.1	—	40.7	54.0	—	37.1	50.6	—	33.2	47.0	—	29.3	43.3		
	3375 cfm	EA (wb)	58	TC	92.5	92.5	105.0	87.4	87.4	99.5	82.0	82.0	93.6	76.2	76.2	87.3	70.0	70.0	80.5
				SHC	80.0	92.5	105.0	75.4	87.4	99.5	70.4	82.0	93.6	65.1	76.2	87.3	59.5	70.0	80.5
62			TC	93.1	93.1	107.0	88.2	88.2	102.3	83.9	83.9	93.2	76.3	76.3	91.1	70.1	70.1	84.1	
			SHC	74.8	90.9	107.0	70.8	86.6	102.3	64.7	78.9	93.2	61.5	76.3	91.1	56.1	70.1	84.1	
67			TC	102.7	102.7	102.7	96.1	96.1	96.1	89.3	89.3	89.3	82.1	82.1	82.1	74.6	74.6	77.9	
			SHC	59.8	76.5	93.1	56.1	72.8	89.5	52.4	69.1	85.8	48.5	65.2	82.0	44.6	61.3	77.9	
72		TC	113.1	113.1	113.1	106.2	106.2	106.2	98.9	98.9	98.9	91.2	91.2	91.2	83.0	83.0	83.0		
		SHC	43.2	59.4	75.6	39.5	55.8	72.0	35.8	52.0	68.3	31.8	48.1	64.4	27.8	44.1	60.4		
76		TC	—	121.7	121.7	—	114.4	114.4	—	106.6	106.6	—	98.3	98.3	—	89.4	89.4		
		SHC	—	45.8	60.8	—	42.2	57.4	—	38.4	53.9	—	34.5	50.1	—	30.4	46.1		
3750 cfm		EA (wb)	58	TC	95.5	95.5	108.3	90.2	90.2	102.6	84.6	84.6	96.5	78.5	78.5	89.9	72.1	72.1	82.8
				SHC	82.7	95.5	108.3	77.8	90.2	102.6	72.7	84.6	96.5	67.2	78.5	89.9	61.4	72.1	82.8
	62		TC	96.8	96.8	109.6	90.3	90.3	106.8	84.7	84.7	100.6	78.7	78.7	93.8	72.2	72.2	86.5	
			SHC	77.0	93.3	109.6	73.8	90.3	106.8	68.8	84.7	100.6	63.5	78.7	93.8	57.9	72.2	86.5	
	67		TC	104.0	104.0	104.0	97.7	97.7	97.7	90.5	90.5	91.6	83.2	83.2	87.5	75.5	75.5	83.3	
			SHC	62.5	80.7	98.9	58.9	77.2	95.4	55.1	73.3	91.6	51.1	69.3	87.5	47.0	65.2	83.3	
	72	TC	114.6	114.6	114.6	107.6	107.6	107.6	100.2	100.2	100.2	92.3	92.3	92.3	84.0	84.0	84.0		
		SHC	44.2	61.9	79.7	40.5	58.3	76.0	36.7	54.5	72.2	32.7	50.5	68.3	28.7	46.4	64.2		
	76	TC	—	123.5	123.5	—	115.6	115.6	—	107.7	107.7	—	99.2	99.2	—	90.2	90.2		
		SHC	—	47.0	63.7	—	43.2	60.1	—	39.5	56.4	—	35.5	52.5	—	31.3	48.3		

LEGEND

- db — dry bulb
- EA — Entering Air Temperature (°F)
- SHC — Sensible Heat Capacity (1000 Btuh) gross
- TC — Total Capacity (1000 Btuh) gross
- wb — wet bulb

38AXZ08/40RLA08 Stage 1 Combination Ratings — 60 Hz

38AXZ08/40RLA08			AMBIENT TEMPERATURE (°F)																
			85			95			105			115			125				
			EA (db)			EA (db)			EA (db)			EA (db)			EA (db)				
			75	80	85	75	80	85	75	80	85	75	80	85	75	80	85		
1900 cfm	EA (wb)	58	TC	60.9	60.9	70.8	57.8	57.8	70.4	54.4	54.4	66.3	51.5	51.5	62.8	46.3	46.3	56.7	
			SHC	51.0	60.9	70.8	45.2	57.8	70.4	42.4	54.4	66.3	40.1	51.5	62.8	36.0	46.3	56.7	
		62	TC	60.9	60.9	74.1	57.8	57.8	70.4	55.4	55.4	71.6	51.4	51.4	62.1	48.0	48.0	58.3	
			SHC	47.7	60.9	74.1	45.2	57.8	70.4	39.2	55.4	71.6	40.7	51.4	62.1	37.7	48.0	58.3	
		67	TC	69.2	69.2	69.2	65.1	65.1	65.1	54.7	54.7	70.8	51.5	51.5	67.7	47.0	47.0	61.5	
			SHC	34.6	51.9	69.2	31.6	48.0	64.5	38.6	54.7	70.8	35.2	51.5	67.7	32.3	46.9	61.5	
	72	TC	76.2	76.2	76.2	72.9	72.9	72.9	68.4	68.4	68.4	63.4	63.4	63.4	59.2	59.2	59.2		
		SHC	23.6	40.8	58.1	22.4	39.7	57.0	23.2	40.6	57.9	18.6	35.9	53.2	16.7	33.3	49.9		
	76	TC	—	83.8	83.8	—	79.1	79.1	—	75.0	75.0	—	69.1	69.1	—	65.2	65.2		
		SHC	—	32.9	49.6	—	31.0	47.6	—	29.5	46.4	—	27.0	42.8	—	25.6	41.9		
	2250 cfm	EA (wb)	58	TC	65.0	65.0	79.1	61.2	61.2	71.2	57.8	57.8	70.4	54.4	54.4	66.5	51.6	51.6	63.2
				SHC	50.9	65.0	79.1	51.2	61.2	71.2	45.1	57.8	70.4	42.4	54.4	66.5	40.1	51.6	63.2
62			TC	65.6	65.6	84.6	61.3	61.3	73.9	57.8	57.8	70.4	55.1	55.1	71.4	50.2	50.2	65.2	
			SHC	46.6	65.6	84.6	48.7	61.3	73.9	45.1	57.8	70.4	38.8	55.1	71.4	35.3	50.2	65.2	
67			TC	71.6	71.6	77.7	68.4	68.4	76.0	58.0	58.0	75.7	58.4	58.4	71.0	50.2	50.2	67.2	
			SHC	36.5	57.1	77.7	34.8	55.4	76.0	40.3	58.0	75.7	30.1	50.6	71.0	33.3	50.2	67.2	
72		TC	79.6	79.6	79.6	74.2	74.2	74.2	70.0	70.0	70.0	66.1	66.1	66.1	60.5	60.5	60.5		
		SHC	24.2	44.8	65.4	22.2	42.8	63.4	20.5	41.1	61.8	18.6	39.1	59.7	16.4	36.9	57.5		
76		TC	—	84.6	84.6	—	80.1	80.1	—	76.1	76.1	—	71.7	71.7	—	63.5	63.5		
		SHC	—	33.8	52.6	—	32.1	51.0	—	30.9	50.8	—	29.1	49.0	—	28.9	49.5		
2650 cfm		EA (wb)	58	TC	69.1	69.1	84.0	65.2	65.2	79.3	61.2	61.2	71.2	58.3	58.3	71.0	53.2	53.2	65.0
				SHC	54.3	69.1	84.0	51.1	65.2	79.3	51.2	61.2	71.2	45.5	58.3	71.0	41.4	53.2	65.0
	62		TC	69.5	69.5	89.4	64.8	64.8	83.5	61.0	61.0	74.0	59.3	59.3	76.6	54.0	54.0	69.9	
			SHC	49.5	69.4	89.4	46.1	64.8	83.5	48.0	61.0	74.0	41.9	59.3	76.6	38.0	54.0	69.9	
	67		TC	73.2	73.2	86.7	69.2	69.2	85.0	65.4	65.4	83.0	60.7	60.7	77.8	55.2	55.2	78.8	
			SHC	38.3	62.5	86.7	36.6	60.8	85.0	34.8	58.9	83.0	32.2	55.0	77.8	30.6	54.7	78.8	
	72	TC	81.5	81.5	81.5	74.9	74.9	74.9	72.3	72.3	72.3	66.4	66.4	67.1	61.2	61.2	64.6		
		SHC	24.2	48.4	72.6	25.5	49.7	73.9	20.6	43.9	67.2	18.7	42.9	67.1	16.3	40.4	64.6		
	76	TC	—	87.1	87.1	—	83.3	83.3	—	78.0	78.0	—	72.5	72.5	—	65.3	65.3		
		SHC	—	35.8	58.5	—	34.5	57.7	—	32.5	55.2	—	30.2	52.3	—	27.1	47.5		
	3000 cfm	EA (wb)	58	TC	70.8	70.8	86.0	68.6	68.6	83.5	63.8	63.8	77.7	60.9	60.9	74.3	56.4	56.4	68.9
				SHC	55.5	70.8	86.0	53.7	68.6	83.5	49.8	63.8	77.7	47.5	60.9	74.3	43.9	56.4	68.9
62			TC	71.0	71.0	91.4	67.0	67.0	86.4	64.1	64.1	82.8	59.6	59.6	77.0	56.0	56.0	72.6	
			SHC	50.5	71.0	91.4	47.6	67.0	86.4	45.4	64.1	82.8	42.1	59.6	77.0	39.5	56.0	72.6	
67			TC	74.4	74.4	94.4	70.7	70.7	90.8	65.8	65.8	86.2	61.2	61.2	80.6	58.3	58.3	76.6	
			SHC	39.9	67.2	94.4	38.0	64.4	90.8	35.4	60.8	86.2	32.8	56.7	80.6	31.1	53.8	76.6	
72		TC	81.9	81.9	81.9	75.3	75.3	81.9	72.7	72.7	73.5	67.5	67.5	72.9	60.9	60.9	70.0		
		SHC	23.8	49.9	76.0	26.9	54.4	81.9	20.2	46.8	73.5	18.1	45.5	72.9	15.8	42.9	70.0		
76		TC	—	87.7	87.7	—	75.3	81.9	—	78.6	78.6	—	73.6	73.6	—	67.6	67.6		
		SHC	—	36.6	61.2	—	54.4	81.9	—	33.4	58.8	—	31.2	55.4	—	29.1	53.5		
3400 cfm		EA (wb)	58	TC	74.6	74.6	90.6	69.7	69.7	84.8	66.9	66.9	81.4	62.5	62.5	76.2	57.7	57.7	70.4
				SHC	58.6	74.6	90.6	54.7	69.7	84.8	52.4	66.9	81.4	48.8	62.5	76.2	45.0	57.7	70.4
	62		TC	74.2	74.2	95.5	69.4	69.4	89.4	66.5	66.5	85.8	62.9	62.9	81.2	57.9	57.9	74.9	
			SHC	52.9	74.2	95.5	49.4	69.4	89.4	47.2	66.5	85.8	44.5	62.9	81.2	40.8	57.9	74.9	
	67		TC	75.8	75.8	97.4	72.0	72.0	94.4	70.1	70.1	83.3	61.9	61.9	88.5	58.0	58.0	83.4	
			SHC	41.1	69.2	97.4	39.2	66.8	94.4	34.2	58.8	83.3	35.3	61.9	88.5	32.6	58.0	83.4	
	72	TC	83.2	83.2	83.2	77.9	77.9	81.9	73.6	73.6	79.6	68.1	68.1	78.3	61.7	61.7	76.8		
		SHC	23.8	53.4	82.9	21.8	51.9	81.9	20.1	49.9	79.6	18.1	48.2	78.3	15.8	46.3	76.8		
	76	TC	—	89.7	89.7	—	85.0	85.0	—	79.5	79.5	—	74.5	74.5	—	68.7	68.7		
		SHC	—	38.6	67.3	—	36.9	65.4	—	34.3	61.6	—	33.7	63.6	—	30.5	57.6		

LEGEND

- db — dry bulb
- EA — Entering Air Temperature (°F)
- SHC — Sensible Heat Capacity (1000 Btuh) gross
- TC — Total Capacity (1000 Btuh) gross
- wb — wet bulb

38AXZ12/40RLA12 Stage 2 Combination Ratings — 60 Hz

38AXZ12/40RLA12			AMBIENT TEMPERATURE (°F)																
			85			95			105			115			125				
			EA (db)			EA (db)			EA (db)			EA (db)			EA (db)				
			75	80	85	75	80	85	75	80	85	75	80	85	75	80	85		
3000 cfm	EA (wb)	58	TC	108.9	108.9	123.2	105.5	105.5	119.3	101.8	101.8	114.9	97.6	97.6	110.4	93.1	93.1	105.3	
			SHC	94.7	108.9	123.2	91.7	105.5	119.3	88.3	101.6	114.9	84.8	97.6	110.4	80.9	93.1	105.3	
		62	TC	114.4	114.4	117.1	109.9	109.9	114.8	105.2	105.2	112.4	100.0	100.0	109.7	94.5	94.5	106.7	
			SHC	85.7	101.4	117.1	83.5	99.2	114.8	81.2	96.8	112.4	78.6	94.1	109.7	75.7	91.2	106.7	
		67	TC	125.3	125.3	125.3	120.4	120.4	120.4	115.1	115.1	115.1	109.3	109.3	109.3	103.1	103.1	103.1	
			SHC	71.3	87.1	102.9	69.1	84.8	100.6	66.7	82.5	98.2	64.2	79.9	95.7	61.5	77.2	93.0	
	72	TC	137.3	137.3	137.3	132.2	132.2	132.2	126.1	126.1	126.1	119.7	119.7	119.7	112.8	112.8	112.8		
		SHC	56.0	72.0	87.9	54.0	69.9	85.7	51.6	67.4	83.3	49.1	64.9	80.7	46.4	62.2	78.0		
	76	TC	—	147.5	147.5	—	141.7	141.7	—	135.3	135.3	—	128.4	128.4	—	121.1	121.1		
		SHC	—	59.4	75.9	—	57.3	73.8	—	54.9	71.3	—	52.4	68.7	—	49.8	65.9		
	3500 cfm	EA (wb)	58	TC	114.3	114.3	129.3	110.6	110.6	125.2	106.5	106.5	120.5	102.0	102.0	115.5	97.1	97.1	109.9
				SHC	99.3	114.3	129.3	96.1	110.6	125.2	92.5	106.5	120.5	88.6	102.0	115.5	84.3	97.1	109.9
62			TC	117.4	117.4	127.6	112.8	112.8	125.1	107.9	107.9	122.2	103.3	103.3	115.7	97.2	97.2	114.3	
			SHC	91.5	109.5	127.6	89.2	107.1	125.1	86.6	104.4	122.2	82.2	99.0	115.7	80.1	97.2	114.3	
67			TC	128.3	128.3	128.3	123.2	123.2	123.2	117.5	117.5	117.5	111.4	111.4	111.4	105.0	105.0	105.0	
			SHC	74.7	92.9	111.1	72.5	90.7	108.9	70.1	88.3	106.4	67.5	85.6	103.8	64.8	83.0	101.1	
72		TC	140.6	140.6	140.6	134.9	134.9	134.9	128.7	128.7	128.7	121.9	121.9	121.9	114.7	114.7	114.7		
		SHC	57.2	75.5	93.7	55.0	73.3	91.5	52.6	70.8	89.1	50.1	68.2	86.4	47.4	65.5	83.6		
76		TC	—	150.8	150.8	—	144.6	144.6	—	137.9	137.9	—	130.6	130.6	—	122.8	122.8		
		SHC	—	61.0	79.9	—	58.8	77.5	—	56.4	75.1	—	53.8	72.3	—	51.1	69.5		
4000 cfm		EA (wb)	58	TC	118.5	118.5	134.1	114.5	114.5	129.6	110.1	110.1	124.7	105.3	105.3	119.2	100.0	100.0	113.2
				SHC	102.9	118.5	134.1	99.4	114.5	129.6	95.5	110.1	124.7	91.3	105.3	119.2	86.7	100.0	113.2
	62		TC	119.8	119.8	136.7	115.2	115.2	133.5	110.2	110.2	129.7	105.4	105.4	124.1	100.1	100.1	117.8	
			SHC	96.5	116.6	136.7	93.8	113.6	133.5	90.8	110.2	129.7	86.8	105.4	124.1	82.4	100.1	117.8	
	67		TC	130.4	130.4	130.4	125.0	125.0	125.0	119.1	119.1	119.1	112.7	112.7	112.7	105.8	105.8	108.6	
			SHC	77.9	98.4	119.0	75.6	96.1	116.7	73.2	93.8	114.3	70.5	91.0	111.5	67.7	88.1	108.6	
	72	TC	142.7	142.7	142.7	136.8	136.8	136.8	130.4	130.4	130.4	123.3	123.3	123.3	116.0	116.0	116.0		
		SHC	58.1	78.7	99.3	55.8	76.4	97.0	53.4	73.9	94.5	50.8	71.3	91.7	48.1	68.5	88.9		
	76	TC	—	153.0	153.0	—	146.6	146.6	—	139.6	139.6	—	132.1	132.1	—	124.2	124.2		
		SHC	—	62.4	83.4	—	60.1	81.0	—	57.7	78.5	—	55.0	75.7	—	52.3	72.9		
	4500 cfm	EA (wb)	58	TC	121.8	121.8	138.0	117.5	117.5	133.2	112.9	112.9	127.9	107.9	107.9	122.3	102.2	102.2	115.9
				SHC	105.6	121.8	138.0	101.9	117.5	133.2	97.9	112.9	127.9	93.5	107.9	122.3	88.6	102.2	115.9
62			TC	121.9	121.9	143.6	117.7	117.7	138.5	113.0	113.0	133.0	107.9	107.9	127.0	102.3	102.3	120.5	
			SHC	100.3	121.9	143.6	96.8	117.7	138.5	92.9	113.0	133.0	88.7	107.9	127.0	84.1	102.3	120.5	
67			TC	131.7	131.7	131.7	126.1	126.1	126.1	120.0	120.0	121.5	113.5	113.5	118.6	106.5	106.5	115.5	
			SHC	80.7	103.6	126.4	78.4	101.2	124.0	75.9	98.7	121.5	73.2	95.9	118.6	70.3	92.9	115.5	
72		TC	144.2	144.2	144.2	138.0	138.0	138.0	131.4	131.4	131.4	124.1	124.1	124.1	116.4	116.4	116.4		
		SHC	58.6	81.5	104.4	56.4	79.3	102.2	53.9	76.7	99.5	51.3	74.0	96.7	48.5	71.1	93.8		
76		TC	—	154.4	154.4	—	147.7	147.7	—	140.5	140.5	—	132.8	132.8	—	124.6	124.6		
		SHC	—	63.4	86.6	—	61.1	84.2	—	58.6	81.6	—	55.9	78.7	—	53.1	75.8		
5000 cfm		EA (wb)	58	TC	124.3	124.3	141.0	119.9	119.9	135.9	115.1	115.1	130.5	109.7	109.7	124.4	103.9	103.9	117.8
				SHC	107.7	124.3	141.0	103.8	119.9	135.9	99.7	115.1	130.5	94.9	109.7	124.4	89.9	103.9	117.8
	62		TC	124.5	124.5	146.7	120.0	120.0	141.4	115.1	115.1	135.7	109.7	109.7	129.4	103.9	103.9	122.6	
			SHC	102.2	124.5	146.7	98.5	120.0	141.4	94.5	115.1	135.7	90.1	109.7	129.4	85.2	103.9	122.6	
	67		TC	132.4	132.4	133.4	126.7	126.7	130.8	120.5	120.5	128.1	113.8	113.8	125.2	106.7	106.7	121.8	
			SHC	83.2	108.3	133.4	80.8	105.8	130.8	78.3	103.2	128.1	75.5	100.3	125.2	72.4	97.1	121.8	
	72	TC	144.9	144.9	144.9	138.6	138.6	138.6	131.8	131.8	131.8	124.3	124.3	124.3	116.5	116.5	116.5		
		SHC	58.9	84.0	109.1	56.6	81.7	106.7	54.2	79.1	104.1	51.5	76.4	101.3	48.7	73.5	98.3		
	76	TC	—	155.1	155.1	—	148.3	148.3	—	140.9	140.9	—	132.9	132.9	—	124.7	124.7		
		SHC	—	64.1	89.4	—	61.7	87.0	—	59.2	84.3	—	56.5	81.4	—	53.7	78.3		

LEGEND

- db — dry bulb
- EA — Entering Air Temperature (°F)
- SHC — Sensible Heat Capacity (1000 Btuh) gross
- TC — Total Capacity (1000 Btuh) gross
- wb — wet bulb

38AXZ12/40RLA12 Stage 1 Combination Ratings — 60 Hz

38AXZ12/40RLA12			AMBIENT TEMPERATURE (°F)																
			85			95			105			115			125				
			EA (db)			EA (db)			EA (db)			EA (db)			EA (db)				
			75	80	85	75	80	85	75	80	85	75	80	85	75	80	85		
2500 cfm	EA (wb)	58	TC	78.8	78.8	89.0	75.4	75.4	85.2	71.5	71.5	80.9	67.4	67.4	76.2	62.8	62.8	71.1	
			SHC	68.5	78.8	89.0	65.5	75.4	85.2	62.2	71.5	80.9	58.6	67.4	76.2	54.6	62.8	71.1	
		62	TC	79.6	79.6	90.9	75.5	75.5	88.6	71.6	71.6	84.1	67.5	67.5	79.2	62.9	62.9	73.9	
			SHC	64.4	77.7	90.9	62.3	75.5	88.6	59.1	71.6	84.1	55.7	67.5	79.2	51.9	62.9	73.9	
		67	TC	87.3	87.3	87.3	82.7	82.7	82.7	77.7	77.7	77.7	72.2	72.2	72.2	66.3	66.3	70.2	
			SHC	51.9	65.4	78.9	50.1	63.5	77.0	48.0	61.5	74.9	45.8	59.2	72.7	43.4	56.8	70.2	
	72	TC	96.0	96.0	96.0	91.2	91.2	91.2	85.9	85.9	85.9	80.0	80.0	80.0	73.6	73.6	73.6		
		SHC	39.0	52.5	66.1	37.2	50.7	64.3	35.2	48.7	62.2	33.1	46.6	60.1	30.8	44.3	57.7		
	76	TC	—	103.4	103.4	—	98.4	98.4	—	92.8	92.8	—	86.6	86.6	—	79.8	79.8		
		SHC	—	41.9	55.6	—	40.2	53.8	—	38.3	51.9	—	36.2	49.8	—	33.9	47.4		
	3000 cfm	EA (wb)	58	TC	83.2	83.2	94.1	79.5	79.5	89.9	75.4	75.4	85.3	70.9	70.9	80.2	66.0	66.0	74.6
				SHC	72.3	83.2	94.1	69.1	79.5	89.9	65.5	75.4	85.3	61.6	70.9	80.2	57.3	66.0	74.6
62			TC	83.3	83.3	97.8	79.6	79.6	93.5	75.5	75.5	88.7	70.9	70.9	83.4	66.0	66.0	77.6	
			SHC	68.7	83.3	97.8	65.7	79.6	93.5	62.2	75.5	88.7	58.5	70.9	83.4	54.4	66.0	77.6	
67			TC	89.3	89.3	89.3	84.6	84.6	85.8	79.3	79.3	83.7	73.7	73.7	81.2	67.5	67.5	78.7	
			SHC	55.8	71.8	87.8	53.8	69.8	85.8	51.8	67.7	83.7	49.5	65.3	81.2	47.0	62.9	78.7	
72		TC	98.1	98.1	98.1	93.1	93.1	93.1	87.5	87.5	87.5	81.4	81.4	81.4	74.7	74.7	74.7		
		SHC	40.3	56.3	72.4	38.5	54.5	70.6	36.5	52.5	68.6	34.3	50.3	66.4	32.0	48.0	64.0		
76		TC	—	105.5	105.5	—	100.3	100.3	—	94.5	94.5	—	88.0	88.0	—	81.0	81.0		
		SHC	—	43.7	59.9	—	42.0	58.1	—	40.0	56.1	—	37.9	53.9	—	35.6	51.5		
3500 cfm		EA (wb)	58	TC	86.5	86.5	97.9	82.6	82.6	93.5	78.2	78.2	88.6	73.4	73.4	83.1	68.2	68.2	77.2
				SHC	75.1	86.5	97.9	71.7	82.6	93.5	67.9	78.2	88.6	63.7	73.4	83.1	59.2	68.2	77.2
	62		TC	86.6	86.6	101.8	82.7	82.7	97.2	78.3	78.3	91.9	73.5	73.5	86.5	68.3	68.3	80.3	
			SHC	71.3	86.6	101.8	68.1	82.7	97.2	64.4	78.1	91.9	60.5	73.5	86.5	56.2	68.3	80.3	
	67		TC	90.6	90.6	96.1	86.6	86.6	94.5	80.4	80.4	91.8	74.6	74.6	89.0	68.5	68.5	85.8	
			SHC	59.2	77.6	96.1	57.6	76.1	94.5	55.1	73.5	91.8	52.7	70.8	89.0	50.0	67.9	85.8	
	72	TC	99.3	99.3	99.3	94.6	94.6	94.6	88.4	88.4	88.4	82.1	82.1	82.1	75.2	75.2	75.2		
		SHC	41.3	59.9	78.4	39.6	58.2	76.7	37.5	56.0	74.5	35.3	53.8	72.3	33.0	51.4	69.8		
	76	TC	—	106.8	106.8	—	101.4	101.4	—	95.4	95.4	—	88.7	88.7	—	81.5	81.5		
		SHC	—	45.3	63.9	—	43.5	62.1	—	41.5	60.0	—	39.3	57.7	—	37.0	55.2		
	4000 cfm	EA (wb)	58	TC	88.9	88.9	100.7	84.8	84.8	96.1	80.3	80.3	90.9	75.3	75.3	85.2	69.7	69.7	79.1
				SHC	77.1	88.9	100.7	73.6	84.8	96.1	69.6	80.3	90.9	65.2	75.2	85.2	60.4	69.7	79.1
62			TC	89.0	89.0	104.7	84.9	84.9	99.9	80.3	80.3	94.6	75.3	75.3	88.7	69.7	69.7	82.2	
			SHC	73.2	89.0	104.7	69.9	84.9	99.9	66.1	80.3	94.6	61.9	75.3	88.7	57.3	69.7	82.2	
67			TC	91.3	91.3	103.8	86.5	86.5	101.6	81.1	81.1	98.9	75.6	75.6	93.9	69.8	69.8	88.5	
			SHC	62.3	83.1	103.8	60.3	80.9	101.6	58.0	78.5	98.9	54.7	74.3	93.9	51.2	69.8	88.5	
72		TC	99.9	99.9	99.9	94.7	94.7	94.7	88.8	88.8	88.8	82.3	82.3	82.3	75.3	75.3	75.3		
		SHC	42.1	63.1	84.1	40.3	61.3	82.2	38.3	59.2	80.1	36.1	56.9	77.8	33.7	54.5	75.3		
76		TC	—	107.4	107.4	—	101.9	101.9	—	95.8	95.8	—	89.0	89.0	—	81.6	81.6		
		SHC	—	46.5	67.5	—	44.7	65.6	—	42.7	63.5	—	40.5	61.1	—	38.1	58.4		
4500 cfm		EA (wb)	58	TC	90.6	90.6	102.7	86.4	86.4	98.0	81.7	81.7	92.6	76.4	76.4	86.7	70.7	70.7	80.2
				SHC	78.5	90.6	102.7	74.8	86.4	98.0	70.7	81.7	92.6	66.1	76.4	86.7	61.1	70.7	80.2
	62		TC	90.7	90.7	106.8	86.5	86.5	101.9	81.7	81.7	96.3	76.5	76.5	90.2	70.7	70.7	83.5	
			SHC	74.5	90.7	106.8	71.0	86.5	101.9	67.1	81.7	96.3	62.7	76.5	90.2	58.0	70.7	83.5	
	67		TC	91.7	91.7	110.7	86.9	86.9	107.9	81.8	81.8	103.7	76.5	76.5	97.1	70.8	70.8	89.8	
			SHC	64.9	87.8	110.7	62.7	85.3	107.9	59.9	81.8	103.7	56.0	76.5	97.1	51.7	70.8	89.8	
	72	TC	100.0	100.0	100.0	94.7	94.7	94.7	88.7	88.7	88.7	82.2	82.2	83.1	75.0	75.0	80.5		
		SHC	42.6	66.0	89.4	40.8	64.2	87.5	38.8	62.1	85.4	36.6	59.8	83.1	34.2	57.3	80.5		
	76	TC	—	107.5	107.5	—	102.0	102.0	—	95.7	95.7	—	88.8	88.8	—	81.2	81.2		
		SHC	—	47.5	70.8	—	45.7	68.8	—	43.7	66.6	—	41.4	64.1	—	38.8	61.2		

LEGEND

- db — dry bulb
- EA — Entering Air Temperature (°F)
- SHC — Sensible Heat Capacity (1000 Btuh) gross
- TC — Total Capacity (1000 Btuh) gross
- wb — wet bulb

38AXD12/40RLA12 Stage 3 Combination Ratings — 60 Hz

38AXD12/40RLA12				AMBIENT TEMPERATURE (°F)															
				85			95			105			115			125			
				EA (db)			EA (db)			EA (db)			EA (db)			EA (db)			
				75	80	85	75	80	85	75	80	85	75	80	85	75	80	85	
3000 cfm	EA (wb)	58	TC	101.5	101.5	115.7	97.9	97.9	111.6	94.4	94.4	107.6	90.3	90.3	103.0	86.1	86.1	98.1	
			SHC	87.3	101.5	115.7	84.2	97.9	111.6	81.2	94.4	107.6	77.7	90.3	103.0	74.0	86.1	98.1	
		62	TC	106.6	106.6	106.6	102.7	102.7	105.5	98.3	98.3	104.3	93.2	93.2	101.9	87.9	87.9	99.3	
			SHC	76.6	91.6	106.5	75.2	90.3	105.5	73.7	89.0	104.3	71.4	86.6	101.9	69.0	84.1	99.3	
		67	TC	119.2	119.2	119.2	114.5	114.5	114.5	109.7	109.7	109.7	103.9	103.9	103.9	97.6	97.6	97.6	
			SHC	62.9	77.8	92.7	61.1	76.1	91.1	59.4	74.6	89.7	57.2	72.4	87.6	54.8	70.1	85.3	
	72	TC	134.0	134.0	134.0	127.3	127.3	127.3	121.7	121.7	121.7	115.4	115.4	115.4	108.5	108.5	108.5		
		SHC	49.6	65.4	81.2	47.1	61.7	76.2	45.1	59.7	74.4	42.9	57.7	72.6	40.5	55.4	70.3		
	76	TC	—	143.8	143.8	—	138.2	138.2	—	132.0	132.0	—	125.0	125.0	—	117.7	117.7		
		SHC	—	51.2	67.7	—	49.7	66.2	—	47.9	62.8	—	45.8	59.3	—	43.6	57.7		
	3500 cfm	EA (wb)	58	TC	107.8	107.8	122.7	104.4	104.4	118.8	100.2	100.2	114.1	95.9	95.9	109.2	91.2	91.2	103.8
				SHC	92.9	107.8	122.7	89.9	104.4	118.8	86.4	100.2	114.1	82.7	95.9	109.2	78.6	91.2	103.8
62			TC	112.3	112.3	121.5	106.9	106.9	117.8	102.0	102.0	115.4	96.8	96.8	112.1	91.9	91.9	106.7	
			SHC	85.7	103.6	121.5	82.7	100.3	117.8	80.5	97.9	115.4	77.7	94.9	112.1	73.9	90.3	106.7	
67			TC	124.6	124.6	124.6	118.4	118.4	118.4	112.9	112.9	112.9	106.7	106.7	106.7	100.2	100.2	100.2	
			SHC	69.0	87.0	105.1	65.9	83.3	100.7	63.9	81.4	99.0	61.6	79.1	96.7	59.2	76.8	94.4	
72		TC	138.2	138.2	138.2	131.3	131.3	131.3	125.2	125.2	125.2	118.4	118.4	118.4	111.2	111.2	111.2		
		SHC	51.8	69.9	88.1	49.2	66.2	83.2	47.0	64.2	81.3	44.7	61.9	79.1	42.2	59.5	76.7		
76		TC	—	148.0	148.0	—	142.0	142.0	—	135.3	135.3	—	128.0	128.0	—	120.1	120.1		
		SHC	—	54.1	71.4	—	52.2	67.4	—	50.3	66.2	—	48.1	64.4	—	45.7	62.3		
4000 cfm		EA (wb)	58	TC	113.0	113.0	128.5	109.2	109.2	124.1	105.3	105.3	119.7	100.5	100.5	114.2	95.4	95.4	108.4
				SHC	97.5	113.0	128.5	94.3	109.2	124.1	90.9	105.3	119.7	86.7	100.5	114.2	82.4	95.4	108.4
	62		TC	115.7	115.7	132.1	110.4	110.4	127.5	105.8	105.8	122.3	100.6	100.6	118.8	95.5	95.5	112.9	
			SHC	92.2	112.2	132.1	88.8	108.1	127.5	85.1	103.7	122.3	82.2	100.5	118.8	78.1	95.5	112.9	
	67		TC	126.7	126.7	126.7	121.3	121.3	121.3	115.4	115.4	115.4	109.0	109.0	109.0	102.1	102.1	103.1	
			SHC	72.1	91.8	111.5	70.2	90.1	109.9	68.1	88.0	107.8	65.8	85.7	105.6	63.3	83.2	103.1	
	72	TC	140.3	140.3	140.3	134.3	134.3	134.3	127.7	127.7	127.7	120.7	120.7	120.7	113.1	113.1	113.1		
		SHC	52.9	72.2	91.4	50.9	70.2	89.5	48.7	68.1	87.6	46.3	65.8	85.3	43.8	63.3	82.8		
	76	TC	—	151.4	151.4	—	145.0	145.0	—	137.9	137.9	—	130.3	130.3	—	122.2	122.2		
		SHC	—	56.2	73.8	—	54.3	72.4	—	52.2	70.8	—	50.0	68.7	—	47.5	66.4		
	4500 cfm	EA (wb)	58	TC	117.7	117.7	133.6	113.5	113.5	128.9	109.2	109.2	124.0	104.2	104.2	118.4	98.8	98.8	112.2
				SHC	101.7	117.7	133.6	98.1	113.5	128.9	94.3	109.2	124.0	90.1	104.2	118.4	85.4	98.8	112.2
62			TC	119.7	119.7	133.3	114.3	114.3	133.4	109.3	109.3	129.0	104.3	104.3	123.2	98.9	98.9	116.8	
			SHC	93.9	113.6	133.3	92.8	113.1	133.4	89.5	109.3	129.0	85.5	104.3	123.2	81.1	98.9	116.8	
67			TC	129.4	129.4	129.4	123.8	123.8	123.8	117.4	117.4	117.4	110.7	110.7	113.9	104.1	104.1	111.3	
			SHC	76.4	98.5	120.6	74.5	96.6	118.7	72.1	94.3	116.4	69.7	91.8	113.9	67.3	89.3	111.3	
72		TC	142.7	142.7	142.7	136.5	136.5	136.5	129.7	129.7	129.7	122.5	122.5	122.5	114.9	114.9	114.9		
		SHC	54.4	75.9	97.5	52.4	74.0	95.6	50.1	71.7	93.4	47.7	69.4	91.1	45.3	67.0	88.7		
76		TC	—	154.1	154.1	—	147.2	147.2	—	139.9	139.9	—	131.9	131.9	—	123.7	123.7		
		SHC	—	58.2	78.5	—	56.1	76.7	—	53.9	74.7	—	51.5	72.6	—	49.1	70.2		
5000 cfm		EA (wb)	58	TC	121.9	121.9	138.3	117.4	117.4	133.2	112.6	112.6	127.8	107.5	107.5	121.9	101.8	101.8	115.6
				SHC	105.5	121.9	138.3	101.5	117.4	133.2	97.4	112.6	127.8	93.0	107.5	121.9	88.1	101.8	115.6
	62		TC	121.7	121.7	143.5	117.5	117.5	138.6	112.8	112.8	133.0	107.6	107.6	126.9	101.8	101.8	120.0	
			SHC	99.8	121.7	143.5	96.4	117.5	138.6	92.5	112.8	133.0	88.2	107.6	126.9	83.5	101.8	120.0	
	67		TC	131.2	131.2	131.2	125.2	125.2	126.8	118.8	118.8	124.3	112.1	112.1	121.8	105.0	105.0	119.1	
			SHC	80.3	104.6	128.9	78.2	102.5	126.8	75.8	100.1	124.3	73.4	97.6	121.8	70.9	95.0	119.1	
	72	TC	144.9	144.9	144.9	138.3	138.3	138.3	131.3	131.3	131.3	123.9	123.9	123.9	116.0	116.0	116.0		
		SHC	55.8	79.6	103.4	53.7	77.5	101.3	51.4	75.2	99.1	49.0	72.8	96.7	46.4	70.3	94.2		
	76	TC	—	156.1	156.1	—	148.9	148.9	—	141.3	141.3	—	133.2	133.2	—	124.8	124.8		
		SHC	—	59.7	82.4	—	57.6	80.4	—	55.3	78.4	—	52.9	76.1	—	50.4	73.7		

LEGEND

- db — dry bulb
- EA — Entering Air Temperature (°F)
- SHC — Sensible Heat Capacity (1000 Btuh) gross
- TC — Total Capacity (1000 Btuh) gross
- wb — wet bulb

38AXD12/40RLA12 Stage 2 Combination Ratings — 60 Hz

38AXD12/40RLA12				AMBIENT TEMPERATURE (°F)															
				85			95			105			115			125			
				EA (db)			EA (db)			EA (db)			EA (db)			EA (db)			
				75	80	85	75	80	85	75	80	85	75	80	85	75	80	85	
2500 cfm	EA (wb)	58	TC	86.5	86.5	95.5	83.2	83.2	93.0	80.1	80.1	89.7	75.7	75.7	85.9	71.5	71.5	81.2	
			SHC	73.2	84.3	95.5	71.1	82.1	93.0	68.5	79.1	89.7	65.4	75.6	85.9	61.8	71.5	81.2	
		62	TC	90.8	90.8	92.0	87.0	87.0	89.4	83.0	83.0	86.5	78.4	78.4	82.9	73.4	73.4	79.3	
			SHC	66.8	79.4	92.0	64.6	77.0	89.4	62.1	74.3	86.5	59.3	71.1	82.9	56.2	67.7	79.3	
		67	TC	101.4	101.4	101.4	96.6	96.6	96.6	91.7	91.7	91.7	86.1	86.1	86.1	79.9	79.9	79.9	
			SHC	55.5	68.6	81.6	53.1	65.7	78.3	51.1	63.7	76.4	48.9	61.6	74.2	46.5	59.2	71.9	
	72	TC	112.4	112.4	112.4	107.0	107.0	107.0	101.7	101.7	101.7	95.7	95.7	95.7	89.3	89.3	89.3		
		SHC	43.0	56.2	69.4	41.0	52.9	64.9	39.0	51.3	63.5	36.8	49.2	61.5	34.6	47.7	60.8		
	76	TC	—	120.9	120.9	—	115.9	115.9	—	110.2	110.2	—	103.8	103.8	—	96.5	96.5		
		SHC	—	44.8	57.3	—	43.1	55.8	—	41.2	54.1	—	38.8	51.9	—	36.8	49.9		
	3000 cfm	EA (wb)	58	TC	92.0	92.0	104.4	88.7	88.7	100.6	85.3	85.3	96.8	80.8	80.8	91.6	76.0	76.0	86.2
				SHC	79.7	92.0	104.4	76.8	88.7	100.6	73.9	85.3	96.8	70.0	80.8	91.6	65.8	76.0	86.2
62			TC	95.5	95.5	100.6	91.6	91.6	97.6	87.2	87.2	94.6	82.3	82.3	90.9	76.9	76.9	86.9	
			SHC	72.2	86.4	100.6	69.7	83.7	97.6	67.2	80.9	94.6	64.2	77.6	90.9	61.0	73.9	86.9	
67			TC	104.6	104.6	104.6	99.9	99.9	99.9	94.7	94.7	94.7	88.6	88.6	88.6	82.4	82.4	82.4	
			SHC	59.0	73.8	88.7	57.4	72.4	87.3	55.4	70.3	85.3	53.1	68.1	83.1	50.7	65.7	80.7	
72		TC	115.7	115.7	115.7	110.6	110.6	110.6	104.9	104.9	104.9	98.5	98.5	98.5	91.4	91.4	91.4		
		SHC	44.6	58.9	73.2	42.8	57.2	71.7	40.7	55.4	70.0	38.5	53.2	67.9	36.0	50.8	65.6		
76		TC	—	125.2	125.2	—	119.8	119.8	—	113.5	113.5	—	107.1	107.1	—	99.0	99.0		
		SHC	—	46.7	62.0	—	45.0	60.4	—	43.2	58.8	—	41.3	54.7	—	38.8	52.9		
3500 cfm		EA (wb)	58	TC	97.4	97.4	110.4	93.5	93.5	106.0	89.5	89.5	101.4	84.8	84.8	96.1	79.7	79.7	90.3
				SHC	84.4	97.4	110.4	81.0	93.5	106.0	77.5	89.5	101.4	73.5	84.8	96.1	69.1	79.7	90.3
	62		TC	99.2	99.2	108.6	95.1	95.1	105.4	90.5	90.5	102.0	85.5	85.5	98.1	80.1	80.1	93.2	
			SHC	77.1	92.9	108.6	74.6	90.0	105.4	71.9	86.9	102.0	68.8	83.4	98.1	65.3	79.2	93.2	
	67		TC	107.3	107.3	107.3	102.4	102.4	102.4	96.8	96.8	96.8	90.7	90.7	91.3	84.2	84.2	87.4	
			SHC	63.2	80.4	97.6	61.4	78.6	95.8	59.3	76.5	93.8	56.9	74.1	91.3	53.9	70.7	87.4	
	72	TC	118.7	118.7	118.7	113.3	113.3	113.3	107.2	107.2	107.2	100.5	100.5	100.5	93.1	93.1	93.1		
		SHC	46.1	62.9	79.6	44.3	61.1	78.0	42.2	59.1	76.1	39.9	56.9	73.9	37.4	54.5	71.5		
	76	TC	—	128.2	128.2	—	122.4	122.4	—	115.9	115.9	—	108.7	108.7	—	100.9	100.9		
		SHC	—	48.7	66.7	—	47.1	62.3	—	45.1	61.0	—	42.9	59.2	—	40.6	57.0		
	4000 cfm	EA (wb)	58	TC	101.2	101.2	114.6	97.4	97.4	110.3	93.0	93.0	105.4	88.2	88.2	99.9	82.7	82.7	93.7
				SHC	87.8	101.2	114.6	84.5	97.4	110.3	80.7	93.0	105.4	76.5	88.2	99.9	71.7	82.7	93.7
62			TC	102.4	102.4	115.6	98.1	98.1	112.3	93.4	93.4	108.5	88.6	88.6	102.2	82.8	82.8	97.3	
			SHC	81.5	98.6	115.6	78.9	95.6	112.3	76.1	92.3	108.5	71.8	87.0	102.2	68.1	82.7	97.3	
67			TC	109.4	109.4	109.4	104.3	104.3	104.3	98.6	98.6	101.5	92.5	92.5	97.9	86.2	86.2	93.1	
			SHC	67.1	86.5	105.9	65.1	84.5	103.9	62.9	82.2	101.5	60.1	79.0	97.9	56.6	74.9	93.1	
72		TC	120.9	120.9	120.9	115.2	115.2	115.2	109.0	109.0	109.0	102.1	102.1	102.1	94.5	94.5	94.5		
		SHC	47.5	66.6	85.6	45.6	64.7	83.8	43.5	62.7	81.8	41.2	60.4	79.6	38.7	58.0	77.2		
76		TC	—	130.5	130.5	—	124.4	124.4	—	117.7	117.7	—	110.3	110.3	—	102.3	102.3		
		SHC	—	50.5	68.2	—	48.7.0	66.8	—	46.7	65.0	—	44.5	63.0	—	42.0	60.7		
4500 cfm		EA (wb)	58	TC	104.7	104.7	118.5	100.6	100.6	113.9	96.1	96.1	108.8	90.9	90.9	103.0	85.2	85.2	96.5
				SHC	90.8	104.7	118.5	87.3	100.6	113.9	83.4	96.1	108.8	78.9	90.9	103.0	73.9	85.2	96.5
	62		TC	105.1	105.1	121.9	100.9	100.9	117.5	96.5	96.5	112.0	91.0	91.0	106.9	85.3	85.3	100.3	
			SHC	85.7	103.8	121.9	82.5	100.0	117.5	78.7	95.3	112.0	74.9	90.9	106.9	70.3	85.3	100.3	
	67		TC	111.1	111.1	113.5	106.0	106.0	111.1	100.4	100.4	107.4	94.4	94.4	103.0	87.2	87.2	98.3	
			SHC	70.6	92.0	113.5	68.5	89.8	111.1	65.7	86.6	107.4	62.5	82.7	103.0	57.3	77.8	98.3	
	72	TC	122.6	122.6	122.6	116.8	116.8	116.8	110.4	110.4	110.4	103.3	103.3	103.3	95.5	95.5	95.5		
		SHC	48.7	69.9	91.2	46.7	68.0	89.4	44.6	66.0	87.3	42.3	63.7	85.1	39.9	61.3	82.7		
	76	TC	—	132.2	132.2	—	126.0	126.0	—	119.1	119.1	—	111.6	111.6	—	103.3	103.3		
		SHC	—	51.9	72.1	—	50.1	70.4	—	48.0	68.6	—	45.7	66.4	—	43.3	64.1		

LEGEND

- db — dry bulb
- EA — Entering Air Temperature (°F)
- SHC — Sensible Heat Capacity (1000 Btuh) gross
- TC — Total Capacity (1000 Btuh) gross
- wb — wet bulb

38AXD12/40RLA12 Stage 1 Combination Ratings — 60 Hz

38AXD12/40RLA12			AMBIENT TEMPERATURE (°F)																
			85			95			105			115			125				
			EA (db)			EA (db)			EA (db)			EA (db)			EA (db)				
			75	80	85	75	80	85	75	80	85	75	80	85	75	80	85		
2500 cfm	EA (wb)	58	TC	40.5	40.5	49.1	38.8	38.8	47.1	36.9	36.9	44.8	34.8	34.8	42.3	32.4	32.4	39.3	
			SHC	31.8	40.5	49.1	30.5	38.8	47.1	29.1	36.9	44.8	27.4	34.8	42.3	25.4	32.4	39.3	
		62	TC	40.5	40.5	52.0	38.9	38.9	49.9	37.0	37.0	47.5	34.8	34.8	44.7	32.4	32.4	41.7	
			SHC	29.0	40.5	52.0	27.8	38.9	49.9	26.5	37.0	47.5	24.9	34.8	44.7	23.2	32.4	41.7	
		67	TC	42.1	42.1	44.6	40.1	40.1	43.9	37.9	37.9	43.1	35.3	35.3	42.2	32.5	32.5	41.3	
			SHC	18.3	31.5	44.6	17.6	30.7	43.9	16.8	29.9	43.1	16.0	29.1	42.2	15.3	28.3	41.3	
	72	TC	46.7	46.7	46.7	44.5	44.5	44.5	42.0	42.0	42.0	39.2	39.2	39.2	36.0	36.0	36.0		
		SHC	11.9	25.1	38.3	11.1	24.3	37.5	10.2	23.4	36.6	9.2	22.4	35.6	8.2	21.3	34.5		
	76	TC	—	50.6	50.6	—	48.2	48.2	—	45.6	45.6	—	42.6	42.6	—	39.2	39.2		
		SHC	—	19.9	33.4	—	19.2	32.5	—	18.3	31.6	—	17.3	30.6	—	16.2	29.5		
	3000 cfm	EA (wb)	58	TC	43.0	43.0	51.9	41.2	41.2	49.7	39.2	39.2	47.2	36.9	36.9	44.5	34.2	34.2	41.3
				SHC	34.2	43.0	51.9	32.7	41.2	49.7	31.1	39.2	47.2	29.3	36.9	44.5	27.2	34.2	41.3
62			TC	43.1	43.1	54.8	41.3	41.3	52.6	39.2	39.2	50.0	36.9	36.9	47.0	34.3	34.3	43.6	
			SHC	31.3	43.1	54.8	30.0	41.3	52.6	28.5	39.2	50.0	26.8	36.9	47.0	24.8	34.2	43.6	
67			TC	43.6	43.6	51.3	41.6	41.6	50.6	39.2	39.2	49.9	36.6	36.6	49.2	34.3	34.3	48.4	
			SHC	20.3	35.8	51.3	19.7	35.1	50.6	19.2	34.5	49.9	18.8	34.0	49.2	20.2	34.3	48.4	
72		TC	48.1	48.1	48.1	45.8	45.8	45.8	43.2	43.2	43.2	40.2	40.2	40.2	36.9	36.9	39.1		
		SHC	11.8	27.4	43.0	11.0	26.6	42.2	10.1	25.7	41.3	9.1	24.7	40.2	8.0	23.6	39.1		
76		TC	—	52.2	52.2	—	49.7	49.7	—	46.9	46.9	—	43.7	43.7	—	40.2	40.2		
		SHC	—	21.0	36.8	—	20.2	35.9	—	19.3	35.0	—	18.3	33.9	—	17.2	32.7		
3500 cfm		EA (wb)	58	TC	44.9	44.9	53.9	43.0	43.0	51.6	40.8	40.8	49.0	38.4	38.4	46.1	35.6	35.6	42.7
				SHC	35.9	44.9	53.9	34.4	43.0	51.6	32.6	40.8	49.0	30.7	38.4	46.1	28.4	35.6	42.7
	62		TC	45.0	45.0	57.0	43.1	43.1	54.5	40.9	40.9	51.8	38.4	38.4	48.7	35.6	35.6	45.1	
			SHC	33.0	45.0	57.0	31.6	43.1	54.5	30.0	40.9	51.8	28.2	38.4	48.7	26.1	35.6	45.1	
	67		TC	45.0	45.0	58.3	42.8	42.8	57.7	40.6	40.6	57.0	38.5	38.5	53.8	35.7	35.7	49.9	
			SHC	23.3	40.8	58.3	23.1	40.4	57.7	23.4	40.2	57.0	23.1	38.5	53.8	21.4	35.7	49.9	
	72	TC	49.3	49.3	49.3	46.8	46.8	46.8	44.1	44.1	45.9	41.0	41.0	44.8	37.5	37.5	43.7		
		SHC	11.9	29.8	47.6	11.1	28.9	46.8	10.2	28.0	45.9	9.2	27.0	44.8	8.1	25.9	43.7		
	76	TC	—	53.3	53.3	—	50.7	50.7	—	47.8	47.8	—	44.5	44.5	—	40.9	40.9		
		SHC	—	22.0	40.0	—	21.2	39.1	—	20.3	38.2	—	19.3	37.1	—	18.1	35.9		
	4000 cfm	EA (wb)	58	TC	46.5	46.5	55.6	44.5	44.5	53.2	42.2	42.2	50.4	39.6	39.6	47.3	36.6	36.6	43.8
				SHC	37.4	46.5	55.6	35.7	44.5	53.2	33.9	42.2	50.4	31.8	39.6	47.3	29.4	36.6	43.8
62			TC	46.5	46.5	58.6	44.5	44.5	56.1	42.2	42.2	53.2	39.6	39.6	49.9	36.7	36.7	46.3	
			SHC	34.4	46.5	58.6	32.9	44.5	56.1	31.2	42.2	53.2	29.3	39.6	49.9	27.1	36.7	46.3	
67			TC	46.3	46.3	65.0	44.6	44.6	61.9	42.3	42.3	58.7	39.7	39.7	55.1	36.7	36.7	51.1	
			SHC	27.7	46.3	65.0	27.2	44.6	61.9	25.8	42.3	58.7	24.2	39.7	55.1	22.4	36.7	51.1	
72		TC	50.1	50.1	52.2	47.6	47.6	51.3	44.7	44.7	50.4	41.6	41.6	49.4	38.0	38.0	48.4		
		SHC	12.0	32.1	52.2	11.2	31.3	51.3	10.4	30.4	50.4	9.4	29.4	49.4	8.6	28.5	48.4		
76		TC	—	54.2	54.2	—	51.5	51.5	—	48.5	48.5	—	45.1	45.1	—	41.4	41.4		
		SHC	—	22.9	43.0	—	22.1	42.1	—	21.1	41.1	—	20.1	40.0	—	19.0	38.7		
4500 cfm		EA (wb)	58	TC	47.7	47.7	56.9	45.6	45.6	54.4	43.3	43.3	51.6	40.6	40.6	48.4	37.5	37.5	44.7
				SHC	38.6	47.7	56.9	36.9	45.6	54.4	34.9	43.3	51.6	32.7	40.6	48.4	30.3	37.5	44.7
	62		TC	47.8	47.8	60.0	45.7	45.7	57.4	43.3	43.3	54.4	40.6	40.6	51.0	37.5	37.5	47.2	
			SHC	35.6	47.8	60.0	34.0	45.7	57.4	32.2	43.3	54.4	30.2	40.6	51.0	27.9	37.5	47.2	
	67		TC	47.8	47.8	66.1	45.7	45.7	63.2	43.3	43.3	59.9	40.6	40.6	56.1	37.6	37.6	52.0	
			SHC	29.6	47.8	66.1	28.3	45.7	63.2	26.8	43.3	59.9	25.1	40.6	56.1	23.2	37.6	52.0	
	72	TC	50.7	50.7	56.6	48.1	48.1	55.8	45.2	45.2	54.9	42.0	42.0	54.0	38.4	38.4	53.0		
		SHC	12.2	34.4	56.6	11.5	33.6	55.8	10.7	32.8	54.9	10.1	32.1	54.0	9.4	31.2	53.0		
	76	TC	—	54.9	54.9	—	52.1	52.1	—	49.0	49.0	—	45.6	45.6	—	41.7	41.7		
		SHC	—	23.6	45.8	—	22.8	44.9	—	21.9	43.8	—	20.8	42.7	—	19.7	41.4		

LEGEND

- db — dry bulb
- EA — Entering Air Temperature (°F)
- SHC — Sensible Heat Capacity (1000 Btuh) gross
- TC — Total Capacity (1000 Btuh) gross
- wb — wet bulb

38AXZ14/40RLA14 Stage 2 Combination Ratings — 60 Hz

38AXZ14/40RLA14			AMBIENT TEMPERATURE (°F)																
			85			95			105			115			125				
			EA (db)			EA (db)			EA (db)			EA (db)			EA (db)				
			75	80	85	75	80	85	75	80	85	75	80	85	75	80	85		
3750 cfm	EA (wb)	58	TC	124.4	124.4	141.8	119.9	119.9	136.8	115.0	115.0	131.2	109.7	109.7	125.1	104.0	104.0	118.6	
			SHC	106.9	124.4	141.8	103.1	119.9	136.8	98.9	115.0	131.2	94.3	109.7	125.1	89.4	104.0	118.6	
		62	TC	130.6	130.6	137.1	124.6	124.6	134.4	118.1	118.1	131.4	111.2	111.2	128.0	104.0	104.0	123.7	
			SHC	96.9	117.0	137.1	94.3	114.3	134.4	91.4	111.4	131.4	88.3	108.2	128.0	84.2	104.0	123.7	
		67	TC	145.9	145.9	145.9	139.2	139.2	139.2	132.0	132.0	132.0	124.2	124.2	124.2	116.2	116.2	116.2	
			SHC	78.6	98.8	119.0	75.9	96.1	116.3	73.2	93.3	113.5	70.2	90.4	110.6	67.2	87.4	107.5	
	72	TC	162.5	162.5	162.5	155.1	155.1	155.1	147.2	147.2	147.2	138.7	138.7	138.7	130.0	130.0	130.0		
		SHC	59.8	80.1	100.4	57.2	77.5	97.8	54.4	74.7	95.0	51.4	71.7	92.0	48.5	68.7	89.0		
	76	TC	—	176.5	176.5	—	168.4	168.4	—	159.8	159.8	—	150.8	150.8	—	141.3	141.3		
		SHC	—	64.8	85.5	—	62.2	82.8	—	59.4	80.0	—	56.6	77.1	—	53.5	74.0		
	4400 cfm	EA (wb)	58	TC	133.0	133.0	151.4	128.1	128.1	145.8	122.7	122.7	139.7	116.8	116.8	132.9	110.7	110.7	125.9
				SHC	114.6	133.0	151.4	110.4	128.1	145.8	105.7	122.7	139.7	100.6	116.8	132.9	95.4	110.7	125.9
62			TC	135.8	135.8	153.0	129.5	129.5	149.8	123.0	123.0	145.7	117.0	117.0	138.6	110.8	110.8	131.2	
			SHC	106.7	129.9	153.0	103.7	126.8	149.8	100.3	123.0	145.7	95.4	117.0	138.6	90.4	110.8	131.2	
67			TC	150.9	150.9	150.9	143.8	143.8	143.8	136.1	136.1	136.1	127.9	127.9	127.9	119.5	119.5	120.2	
			SHC	85.0	108.6	132.1	82.3	105.9	129.4	79.5	103.0	126.5	76.4	99.9	123.4	73.3	96.8	120.2	
72		TC	167.6	167.6	167.6	159.8	159.8	159.8	151.4	151.4	151.4	142.5	142.5	142.5	133.3	133.3	133.3		
		SHC	62.6	86.3	110.0	59.9	83.5	107.2	57.0	80.7	104.3	54.0	77.6	101.2	51.0	74.6	98.1		
76		TC	—	181.6	181.6	—	173.1	173.1	—	164.1	164.1	—	154.5	154.5	—	144.6	144.6		
		SHC	—	68.2	92.2	—	65.4	89.4	—	62.5	86.4	—	59.5	83.3	—	56.4	80.2		
5000 cfm		EA (wb)	58	TC	139.7	139.7	158.8	134.3	134.3	152.7	128.5	128.5	146.1	122.2	122.2	138.9	115.6	115.6	131.4
				SHC	120.6	139.7	158.8	116.0	134.3	152.7	111.0	128.5	146.1	105.5	122.2	138.9	99.8	115.6	131.4
	62		TC	140.6	140.6	163.9	134.5	134.5	159.1	128.7	128.7	152.2	122.4	122.4	144.7	115.8	115.8	136.9	
			SHC	113.7	138.8	163.9	110.0	134.5	159.1	105.2	128.7	152.2	100.1	122.4	144.7	94.7	115.8	136.9	
	67		TC	154.4	154.4	154.4	147.0	147.0	147.0	139.0	139.0	139.0	130.5	130.5	134.8	121.8	121.8	131.5	
			SHC	90.7	117.2	143.8	87.9	114.4	141.0	85.0	111.5	138.0	81.9	108.3	134.8	78.7	105.1	131.5	
	72	TC	171.3	171.3	171.3	163.1	163.1	163.1	154.4	154.4	154.4	145.2	145.2	145.2	135.6	135.6	135.6		
		SHC	64.9	91.6	118.3	62.1	88.8	115.4	59.2	85.8	112.5	56.1	82.8	109.4	53.0	79.6	106.2		
	76	TC	—	185.3	185.3	—	176.4	176.4	—	167.0	167.0	—	157.1	157.1	—	146.9	146.9		
		SHC	—	70.7	97.7	—	67.9	94.9	—	64.9	91.8	—	61.9	88.7	—	58.7	85.4		
	5650 cfm	EA (wb)	58	TC	145.8	145.8	165.5	140.1	140.1	159.0	133.9	133.9	152.0	127.2	127.2	144.4	120.2	120.2	136.5
				SHC	126.0	145.8	165.5	121.1	140.1	159.0	115.8	133.9	152.0	109.9	127.2	144.4	103.9	120.2	136.5
62			TC	146.0	146.0	172.3	140.2	140.2	165.6	134.0	134.0	158.2	127.3	127.3	150.3	120.3	120.3	142.0	
			SHC	119.6	146.0	172.3	114.9	140.2	165.6	109.8	134.0	158.2	104.3	127.3	150.3	98.6	120.3	142.0	
67			TC	157.5	157.5	157.5	149.7	149.7	153.1	141.5	141.5	150.0	132.8	132.8	146.6	123.9	123.9	143.0	
			SHC	96.5	126.2	156.0	93.7	123.4	153.1	90.7	120.3	150.0	87.6	117.1	146.6	84.3	113.7	143.0	
72		TC	174.4	174.4	174.4	165.9	165.9	165.9	156.9	156.9	156.9	147.4	147.4	147.4	137.6	137.6	137.6		
		SHC	67.0	97.0	126.9	64.2	94.1	124.0	61.3	91.1	121.0	58.2	88.0	117.9	55.1	84.9	114.7		
76		TC	—	188.4	188.4	—	179.2	179.2	—	169.5	169.5	—	159.3	159.3	—	148.8	148.8		
		SHC	—	73.1	103.3	—	70.2	100.4	—	67.2	97.2	—	64.1	94.0	—	60.9	90.7		
6250 cfm		EA (wb)	58	TC	150.6	150.6	170.9	144.6	144.6	164.0	138.1	138.1	156.6	131.0	131.0	148.7	123.7	123.7	140.4
				SHC	130.4	150.6	170.9	125.1	144.6	164.0	119.5	138.1	156.6	113.4	131.0	148.7	107.1	123.7	140.4
	62		TC	150.8	150.8	177.8	144.7	144.7	170.7	138.2	138.2	163.0	131.2	131.2	154.7	123.9	123.9	146.1	
			SHC	123.7	150.8	177.8	118.8	144.7	170.7	113.4	138.2	163.0	107.7	131.2	154.7	101.7	123.9	146.1	
	67		TC	159.8	159.8	166.9	151.9	151.9	163.8	143.5	143.5	160.5	134.6	134.6	156.9	125.6	125.6	152.9	
			SHC	101.7	134.3	166.9	98.9	131.4	163.8	95.8	128.2	160.5	92.6	124.8	156.9	89.2	121.0	152.9	
	72	TC	176.7	176.7	176.7	168.0	168.0	168.0	158.8	158.8	158.8	149.1	149.1	149.1	139.0	139.0	139.0		
		SHC	68.8	101.7	134.6	66.0	98.8	131.7	63.0	95.8	128.7	60.0	92.7	125.5	56.9	89.6	122.3		
	76	TC	—	190.7	190.7	—	181.3	181.3	—	171.3	171.3	—	160.9	160.9	—	150.2	150.2		
		SHC	—	75.0	108.1	—	72.1	105.1	—	69.0	101.9	—	65.9	98.6	—	62.6	95.2		

LEGEND

- db — dry bulb
- EA — Entering Air Temperature (°F)
- SHC — Sensible Heat Capacity (1000 Btuh) gross
- TC — Total Capacity (1000 Btuh) gross
- wb — wet bulb

38AXZ14/40RLA14 Stage 1 Combination Ratings — 60 Hz

38AXZ14/40RLA14			AMBIENT TEMPERATURE (°F)																
			85			95			105			115			125				
			EA (db)			EA (db)			EA (db)			EA (db)			EA (db)				
			75	80	85	75	80	85	75	80	85	75	80	85	75	80	85		
3750 cfm	EA (wb)	58	TC	80.5	80.5	91.3	78.4	78.4	88.8	73.9	73.9	83.8	70.5	70.5	80.0	72.2	72.2	81.3	
			SHC	69.8	80.5	91.3	67.9	78.4	88.8	64.0	73.9	83.8	61.1	70.5	80.0	63.1	72.2	81.3	
		62	TC	77.9	77.9	87.6	75.2	75.2	88.6	73.6	73.6	86.7	70.2	70.2	82.8	71.5	71.5	83.5	
			SHC	61.8	74.7	87.6	61.8	75.2	88.6	60.5	73.6	86.7	57.7	70.2	82.8	59.5	71.5	83.5	
		67	TC	92.8	92.8	92.8	88.6	88.6	88.6	88.5	88.5	88.5	74.1	74.1	75.7	73.3	73.3	83.9	
			SHC	55.1	68.5	81.9	52.0	64.3	76.5	57.1	71.9	86.7	46.8	61.2	75.7	54.9	69.4	83.9	
	72	TC	90.8	90.8	90.8	86.7	86.7	86.7	84.4	84.4	84.4	78.9	78.9	78.9	81.7	81.7	81.7		
		SHC	38.0	55.3	72.6	35.3	52.6	70.0	34.4	51.5	68.6	32.9	50.2	67.5	34.1	47.3	60.4		
	76	TC	—	96.9	96.9	—	93.3	93.3	—	90.6	90.6	—	85.9	85.9	—	74.2	74.2		
		SHC	—	39.5	56.2	—	38.8	56.1	—	37.9	55.2	—	36.9	54.3	—	33.2	48.0		
	4400 cfm	EA (wb)	58	TC	86.1	86.1	97.5	81.4	81.4	92.2	76.3	76.3	86.5	75.5	75.5	85.4	74.9	74.9	84.4
				SHC	74.7	86.1	97.5	70.6	81.4	92.2	66.2	76.3	86.5	65.5	75.5	85.4	65.5	74.9	84.4
62			TC	82.6	82.6	97.1	81.8	81.8	96.2	79.3	79.3	93.3	76.1	76.1	89.6	75.7	75.7	88.4	
			SHC	68.0	82.6	97.1	67.3	81.8	96.2	65.3	79.3	93.3	62.7	76.1	89.6	63.0	75.7	88.4	
67			TC	91.3	91.3	91.3	86.7	86.7	86.7	90.4	90.4	90.4	82.7	82.7	82.7	75.3	75.3	95.3	
			SHC	27.7	48.3	68.9	45.6	54.7	63.8	57.7	73.4	89.2	—2.9	17.7	38.3	55.2	75.3	95.3	
72		TC	98.7	98.7	98.7	91.0	91.0	91.0	91.3	91.3	91.3	83.4	83.4	83.4	82.8	82.8	82.8		
		SHC	37.8	50.2	62.6	38.4	59.1	79.7	38.2	58.5	78.8	32.6	45.9	59.2	36.8	54.8	72.9		
76		TC	—	100.3	100.3	—	96.7	96.7	—	98.3	98.3	—	87.1	87.1	—	76.7	76.7		
		SHC	—	41.4	60.0	—	40.6	59.5	—	42.1	60.7	—	39.5	60.1	—	37.1	56.2		
5000 cfm		EA (wb)	58	TC	86.0	86.0	97.3	86.3	86.3	97.7	81.8	81.8	92.5	72.7	72.7	82.3	76.5	76.5	86.2
				SHC	74.7	86.0	97.3	75.0	86.3	97.7	71.0	81.8	92.5	63.1	72.7	82.3	66.9	76.5	86.2
	62		TC	87.2	87.2	102.5	85.9	85.9	101.0	81.2	81.2	95.5	79.4	79.4	93.3	77.4	77.4	90.4	
			SHC	71.9	87.2	102.5	70.8	85.9	101.0	67.0	81.2	95.5	65.5	79.4	93.3	64.4	77.4	90.4	
	67		TC	89.8	89.8	114.0	87.0	87.0	111.2	94.7	94.7	94.7	78.2	78.2	97.5	78.6	78.6	98.4	
			SHC	65.6	89.8	114.0	62.8	87.0	111.2	60.3	76.9	93.4	57.2	77.4	97.5	58.8	78.6	98.4	
	72	TC	97.6	97.6	97.6	98.5	98.5	98.5	92.6	92.6	92.6	87.3	87.3	87.3	83.3	83.3	83.3		
		SHC	38.1	53.6	69.0	19.7	43.9	68.1	40.6	64.8	89.0	33.2	45.3	57.3	37.7	57.1	76.6		
	76	TC	—	104.0	104.0	—	99.8	99.8	—	92.0	92.0	—	89.6	89.6	—	85.9	85.9		
		SHC	—	46.0	70.2	—	44.8	69.0	—	42.8	67.0	—	41.7	65.8	—	43.3	67.0		
	5650 cfm	EA (wb)	58	TC	90.8	90.8	102.7	87.4	87.4	98.8	84.6	84.6	95.7	80.0	80.0	90.5	77.7	77.7	87.5
				SHC	78.9	90.8	102.7	76.0	87.4	98.8	73.5	84.6	95.7	69.6	80.0	90.5	67.9	77.7	87.5
62			TC	90.1	90.1	105.8	89.9	89.9	105.6	85.4	85.4	99.4	80.9	80.9	95.0	78.5	78.5	91.7	
			SHC	74.4	90.1	105.8	74.2	89.9	105.6	71.5	85.4	99.4	66.8	80.9	95.0	65.3	78.5	91.7	
67			TC	92.4	92.4	102.3	90.2	90.2	113.5	97.2	97.2	98.1	79.3	79.3	100.0	79.2	79.2	99.2	
			SHC	62.1	82.2	102.3	66.6	90.1	113.5	59.6	78.9	98.1	58.6	79.3	100.0	59.3	79.2	99.2	
72		TC	100.6	100.6	100.6	98.0	98.0	98.0	95.0	95.0	95.0	88.8	88.8	88.8	83.7	83.7	83.7		
		SHC	38.8	55.0	71.2	38.1	54.8	71.4	35.2	46.5	57.7	37.1	57.5	78.0	39.3	61.3	83.3		
76		TC	—	105.5	105.5	—	97.3	97.3	—	94.2	94.2	—	89.6	89.6	—	86.7	86.7		
		SHC	—	48.3	75.8	—	46.4	73.9	—	45.1	72.6	—	43.8	71.3	—	38.5	55.2		
6250 cfm		EA (wb)	58	TC	94.4	94.4	106.9	89.4	89.4	101.0	87.4	87.4	98.8	84.2	84.2	95.1	78.7	78.7	88.6
				SHC	82.0	94.4	106.9	77.8	89.4	101.0	76.0	87.4	98.8	73.2	84.2	95.1	68.7	78.7	88.6
	62		TC	94.1	94.1	110.5	92.0	92.0	108.0	87.3	87.3	102.5	84.4	84.4	99.1	79.1	79.1	92.4	
			SHC	77.8	94.1	110.5	76.0	92.0	108.0	72.0	87.2	102.5	69.7	84.4	99.1	65.7	79.1	92.4	
	67		TC	93.7	93.7	104.4	89.1	89.1	111.5	89.2	89.2	92.2	85.0	85.0	107.1	80.1	80.1	100.2	
			SHC	63.3	83.9	104.4	65.6	88.6	111.5	19.2	55.7	92.2	62.9	85.0	107.1	59.9	80.1	100.2	
	72	TC	106.6	106.6	106.6	101.4	101.4	101.4	95.3	95.3	95.3	89.5	89.5	89.5	84.1	84.1	88.2		
		SHC	48.3	72.9	97.5	46.5	71.0	95.6	38.3	58.2	78.1	38.5	61.6	84.8	38.7	63.4	88.2		
	76	TC	—	107.5	107.5	—	100.8	100.8	—	97.4	97.4	—	91.0	91.0	—	87.0	87.0		
		SHC	—	50.6	81.7	—	48.7	79.8	—	48.0	79.0	—	46.1	77.2	—	39.7	58.0		

LEGEND

- db — dry bulb
- EA — Entering Air Temperature (°F)
- SHC — Sensible Heat Capacity (1000 Btuh) gross
- TC — Total Capacity (1000 Btuh) gross
- wb — wet bulb

38AXD14/40RLA14 Stage 3 Combination Ratings — 60 Hz

38AXD14/40RLA14			AMBIENT TEMPERATURE (°F)																	
			85			95			105			115			125					
			EA (db)			EA (db)			EA (db)			EA (db)			EA (db)					
			75	80	85	75	80	85	75	80	85	75	80	85	75	80	85			
3750 cfm	EA (wb)	58	TC	129.7	129.7	147.0	125.4	125.4	142.1	120.7	120.7	136.8	115.6	115.6	131.0	110.1	110.1	124.8		
		58	SHC	112.3	129.7	147.0	108.6	125.3	142.1	104.5	120.7	136.8	100.1	115.6	131.0	95.4	110.1	124.8		
		62	TC	136.1	136.1	140.7	130.5	130.5	138.6	124.4	124.4	135.1	118.0	118.0	131.8	111.8	111.8	127.0		
		62	SHC	101.6	121.1	140.7	99.3	118.9	138.6	96.2	115.6	135.1	93.2	112.5	131.8	89.4	108.2	127.0		
		67	TC	150.1	150.1	150.1	143.8	143.8	143.8	137.1	137.1	137.1	130.1	130.1	130.1	122.7	122.7	122.7		
		67	SHC	82.5	102.2	121.8	80.0	99.6	119.3	77.4	97.0	116.6	74.6	94.2	113.8	71.7	91.3	110.9		
	EA (wb)	72	TC	165.2	165.2	165.2	158.1	158.1	158.1	151.0	151.0	151.0	143.1	143.1	143.1	135.5	135.5	135.5		
		72	SHC	63.1	82.8	102.5	60.5	80.3	100.1	57.9	77.6	97.4	55.1	74.9	94.6	52.4	72.1	91.8		
		76	TC	—	177.6	177.6	—	170.4	170.4	—	162.4	162.4	—	153.8	153.8	—	145.8	145.8		
		76	SHC	—	67.1	87.7	—	64.6	84.7	—	62.0	82.5	—	59.2	79.4	—	56.5	76.6		
		4375 cfm	EA (wb)	58	TC	137.4	137.4	155.6	132.7	132.7	150.3	127.8	127.8	144.8	122.1	122.1	138.3	116.2	116.2	131.7
				58	SHC	119.2	137.4	155.6	115.1	132.7	150.3	110.9	127.8	144.8	105.9	122.1	138.3	100.8	116.2	131.7
62	TC			140.5	140.5	155.0	134.9	134.9	152.2	128.8	128.8	148.1	122.8	122.8	142.3	116.3	116.3	136.9		
62	SHC			110.2	132.6	155.0	107.6	129.9	152.2	104.2	126.1	148.1	99.9	121.1	142.3	95.8	116.3	136.9		
67	TC			154.5	154.5	154.5	147.8	147.8	147.8	140.8	140.8	140.8	133.4	133.4	133.4	125.8	125.8	125.8		
67	SHC			88.3	111.1	133.8	85.8	108.6	131.3	83.0	105.8	128.5	80.2	102.9	125.6	77.3	100.0	122.6		
EA (wb)	72		TC	169.7	169.7	169.7	162.4	162.4	162.4	154.9	154.9	154.9	146.8	146.8	146.8	138.7	138.7	138.7		
	72		SHC	65.4	88.3	111.2	62.9	85.7	108.6	60.2	83.0	105.7	57.4	80.3	103.1	54.6	77.3	99.9		
	76		TC	—	182.1	182.1	—	174.3	174.3	—	166.2	166.2	—	157.3	157.3	—	148.8	148.8		
	76		SHC	—	69.9	93.4	—	67.3	90.7	—	64.6	87.8	—	61.8	85.1	—	58.9	81.9		
	5000 cfm		EA (wb)	58	TC	143.3	143.3	162.3	138.3	138.3	156.6	132.9	132.9	150.4	126.9	126.9	143.7	120.7	120.7	136.6
				58	SHC	124.4	143.3	162.3	120.1	138.3	156.6	115.3	132.9	150.4	110.2	126.9	143.7	104.8	120.7	136.6
62		TC		144.5	144.5	167.1	139.1	139.1	160.8	133.3	133.3	156.4	127.1	127.1	149.5	119.3	119.3	140.3		
62		SHC		117.6	142.3	167.1	113.2	137.0	160.8	109.7	133.0	156.4	104.8	127.1	149.5	98.3	119.3	140.3		
67		TC		157.6	157.6	157.6	150.7	150.7	150.7	143.5	143.5	143.5	135.7	135.7	136.0	128.0	128.0	132.9		
67		SHC		93.4	119.0	144.6	90.7	116.3	141.9	88.0	113.5	139.0	85.1	110.6	136.0	82.2	107.5	132.9		
EA (wb)		72	TC	172.9	172.9	172.9	165.5	165.5	165.5	157.6	157.6	157.6	149.3	149.3	149.3	140.8	140.8	140.8		
		72	SHC	67.4	93.0	118.7	64.8	90.3	115.9	62.1	87.6	113.1	59.2	84.7	110.2	56.4	81.8	107.3		
		76	TC	—	185.6	185.6	—	177.6	177.6	—	169.0	169.0	—	159.9	159.9	—	150.9	150.9		
		76	SHC	—	72.1	98.0	—	69.4	95.3	—	66.7	92.5	—	63.8	89.5	—	60.9	86.5		
		5625 cfm	EA (wb)	58	TC	148.6	148.6	168.1	143.4	143.4	162.2	136.3	136.3	154.2	131.3	131.3	148.6	124.9	124.9	141.3
				58	SHC	129.1	148.6	168.1	124.6	143.4	162.2	118.4	136.3	154.2	114.1	131.3	148.6	108.5	124.9	141.3
62	TC			149.8	149.8	171.2	143.6	143.6	168.7	137.6	137.6	161.7	130.9	130.9	153.4	124.8	124.8	146.7		
62	SHC			121.0	146.1	171.2	118.5	143.6	168.7	113.5	137.6	161.7	107.8	130.6	153.4	103.0	124.8	146.7		
67	TC			171.4	171.4	171.4	153.2	153.2	153.2	145.7	145.7	149.9	137.7	137.7	146.9	136.5	136.5	136.5		
67	SHC			55.0	61.9	68.7	95.9	124.4	152.8	93.1	121.5	149.9	90.2	118.5	146.9	50.8	62.6	74.4		
EA (wb)	72		TC	175.7	175.7	175.7	168.0	168.0	168.0	159.8	159.8	159.8	151.3	151.3	151.3	142.7	142.7	142.7		
	72		SHC	69.3	97.9	126.5	66.6	95.2	123.7	63.9	92.4	120.9	61.0	89.4	117.8	58.2	86.5	114.8		
	76		TC	—	188.3	188.3	—	179.9	179.9	—	170.8	170.8	—	162.0	162.0	—	153.0	153.0		
	76		SHC	—	74.2	103.0	—	71.4	100.2	—	68.7	97.4	—	65.7	94.1	—	62.8	90.9		
	6250 cfm		EA (wb)	58	TC	153.0	153.0	173.0	147.2	147.2	166.5	141.3	141.3	159.8	134.7	134.7	152.4	128.2	128.2	144.9
				58	SHC	132.9	152.9	173.0	127.9	147.2	166.5	122.8	141.3	159.8	117.1	134.7	152.4	111.4	128.1	144.9
62		TC		153.2	153.2	179.9	147.3	147.3	173.0	141.4	141.4	166.1	134.4	134.4	157.8	128.3	128.3	150.7		
62		SHC		126.5	153.2	179.9	121.6	147.3	173.0	116.8	141.4	166.1	111.0	134.4	157.8	106.0	128.3	150.7		
67		TC		162.3	162.3	165.6	155.0	155.0	162.7	147.4	147.4	159.7	139.5	139.5	155.7	131.4	131.4	152.4		
67		SHC		103.2	134.4	165.6	100.5	131.6	162.7	97.7	128.7	159.7	94.4	125.0	155.7	91.4	121.9	152.4		
EA (wb)		72	TC	177.8	177.8	177.8	169.8	169.8	169.8	161.6	161.6	161.6	152.9	152.9	152.9	144.1	144.1	144.1		
		72	SHC	70.8	102.0	133.2	68.1	99.4	130.6	65.4	96.5	127.5	62.5	93.5	124.5	59.7	90.6	121.5		
		76	TC	—	190.0	190.0	—	181.4	181.4	—	172.9	172.9	—	163.2	163.2	—	154.2	154.2		
		76	SHC	—	75.9	107.5	—	73.1	104.5	—	70.2	101.2	—	67.2	98.1	—	64.2	94.8		

LEGEND

- db — dry bulb
- EA — Entering Air Temperature (°F)
- SHC — Sensible Heat Capacity (1000 Btuh) gross
- TC — Total Capacity (1000 Btuh) gross
- wb — wet bulb

38AXD14/40RLA14 Stage 2 Combination Ratings — 60 Hz

38AXD14/40RLA14			AMBIENT TEMPERATURE (°F)																
			85			95			105			115			125				
			EA (db)			EA (db)			EA (db)			EA (db)			EA (db)				
			75	80	85	75	80	85	75	80	85	75	80	85	75	80	85		
3150 cfm	EA (wb)	58	TC	114.2	114.2	126.7	110.2	110.2	123.3	106.0	106.0	119.0	101.3	101.3	114.1	96.3	96.3	108.4	
			SHC	98.6	112.7	126.7	95.7	109.5	123.3	92.4	105.7	119.0	88.6	101.3	114.1	84.1	96.3	108.4	
		62	TC	119.1	119.1	121.3	114.2	114.2	118.5	109.6	109.6	114.4	104.1	104.1	110.8	98.3	98.3	106.7	
			SHC	89.7	105.5	121.3	87.2	102.9	118.5	83.9	99.1	114.4	80.8	95.8	110.8	77.3	92.0	106.7	
		67	TC	130.6	130.6	130.6	125.3	125.3	125.3	119.5	119.5	119.5	113.2	113.2	113.2	106.2	106.2	106.2	
			SHC	73.5	89.2	104.8	71.3	87.0	102.6	68.9	84.6	100.3	66.4	82.2	98.0	63.6	79.4	95.2	
	72	TC	142.8	142.8	142.8	136.9	136.9	136.9	130.6	130.6	130.6	123.7	123.7	123.7	116.4	116.4	116.4		
		SHC	57.4	72.2	87.0	55.0	70.0	85.0	52.5	67.7	82.9	49.9	65.2	80.5	47.2	62.6	78.0		
	76	TC	—	153.0	153.0	—	146.7	146.7	—	140.0	140.0	—	132.7	132.7	—	124.6	124.6		
		SHC	—	58.6	74.3	—	56.5	72.4	—	53.9	69.9	—	51.4	67.7	—	49.0	65.3		
	3750 cfm	EA (wb)	58	TC	120.3	120.3	135.5	116.2	116.2	130.9	111.7	111.7	125.8	106.6	106.6	120.1	101.2	101.2	114.0
				SHC	105.0	120.3	135.5	101.5	116.2	130.9	97.5	111.7	125.8	93.2	106.6	120.1	88.4	101.2	114.0
62			TC	123.7	123.7	131.0	118.8	118.8	127.2	113.8	113.8	123.9	108.2	108.2	119.5	102.0	102.0	115.2	
			SHC	95.6	113.3	131.0	92.5	109.9	127.2	89.6	106.7	123.9	86.0	102.8	119.5	82.5	98.8	115.2	
67			TC	134.4	134.4	134.4	128.7	128.7	128.7	122.5	122.5	122.5	115.9	115.9	115.9	108.6	108.6	108.6	
			SHC	78.2	96.6	115.1	75.9	94.4	112.9	73.5	92.1	110.6	70.9	89.4	108.0	68.1	86.6	105.2	
72		TC	146.8	146.8	146.8	140.5	140.5	140.5	133.8	133.8	133.8	126.6	126.6	126.6	119.0	119.0	119.0		
		SHC	58.8	76.6	94.4	56.5	74.4	92.3	54.0	72.0	90.0	51.4	69.5	87.6	48.7	66.9	85.0		
76		TC	—	157.2	157.2	—	150.3	150.3	—	143.1	143.1	—	135.3	135.3	—	127.2	127.2		
		SHC	—	60.1	79.1	—	58.1	77.3	—	55.9	75.1	—	53.5	70.0	—	50.9	68.0		
4400 cfm		EA (wb)	58	TC	125.9	125.9	141.9	121.5	121.5	136.9	116.6	116.6	131.4	111.2	111.2	125.3	105.4	105.4	118.7
				SHC	110.0	125.9	141.9	106.1	121.5	136.9	101.8	116.6	131.4	97.2	111.2	125.3	92.0	105.4	118.7
	62		TC	128.0	128.0	140.4	122.9	122.9	137.2	117.5	117.5	132.9	111.7	111.7	128.5	105.5	105.5	123.3	
			SHC	101.2	120.8	140.4	98.5	117.8	137.2	95.1	114.0	132.9	91.6	110.1	128.5	87.7	105.5	123.3	
	67		TC	137.3	137.3	137.3	131.3	131.3	131.3	124.8	124.8	124.8	118.0	118.0	118.2	110.6	110.6	115.1	
			SHC	82.9	104.3	125.7	80.6	102.0	123.4	78.2	99.6	120.9	75.5	96.9	118.2	72.6	93.8	115.1	
	72	TC	149.9	149.9	149.9	143.3	143.3	143.3	136.4	136.4	136.4	128.9	128.9	128.9	121.0	121.0	121.0		
		SHC	60.3	81.0	101.8	58.0	78.8	99.6	55.5	76.4	97.3	52.9	73.8	94.8	50.2	71.2	92.2		
	76	TC	—	160.1	160.1	—	153.1	153.1	—	145.5	145.5	—	137.4	137.4	—	129.1	129.1		
		SHC	—	62.3	84.7	—	60.1	79.1	—	57.8	77.3	—	55.3	75.1	—	52.6	72.7		
	5000 cfm	EA (wb)	58	TC	130.2	130.2	146.7	125.5	125.5	141.4	120.3	120.3	135.6	114.7	114.7	129.2	108.6	108.6	122.3
				SHC	113.7	130.2	146.7	109.6	125.5	141.4	105.1	120.3	135.6	100.1	114.7	129.2	94.8	108.6	122.3
62			TC	131.2	131.2	148.6	126.0	126.0	144.8	120.4	120.4	140.8	114.8	114.8	134.2	108.7	108.7	127.1	
			SHC	106.2	127.4	148.6	103.3	124.1	144.8	100.1	120.4	140.8	95.4	114.8	134.2	90.3	108.7	127.1	
67			TC	139.2	139.2	139.2	133.2	133.2	133.2	126.7	126.7	130.0	119.7	119.7	126.7	112.9	112.9	120.8	
			SHC	87.1	111.0	134.9	84.8	108.7	132.6	82.3	106.1	130.0	79.4	103.0	126.7	75.3	98.1	120.8	
72		TC	152.0	152.0	152.0	145.3	145.3	145.3	138.1	138.1	138.1	130.4	130.4	130.4	122.3	122.3	122.3		
		SHC	61.5	84.9	108.3	59.2	82.6	106.0	56.7	80.2	103.7	54.1	77.6	101.2	51.4	74.9	98.5		
76		TC	—	162.2	162.2	—	155.0	155.0	—	147.3	147.3	—	139.0	139.0	—	130.4	130.4		
		SHC	—	63.9	85.7	—	61.7	83.7	—	59.3	81.6	—	56.7	79.2	—	54.0	76.6		
5650 cfm		EA (wb)	58	TC	134.0	134.0	151.0	129.1	129.1	145.4	123.7	123.7	139.4	117.7	117.7	132.7	111.4	111.4	125.6
				SHC	117.0	134.0	151.0	112.7	129.1	145.4	108.0	123.7	139.4	102.8	117.7	132.7	97.3	111.4	125.6
	62		TC	134.1	134.1	156.8	129.1	129.1	151.0	123.7	123.7	144.6	117.8	117.8	137.7	111.5	111.5	130.3	
			SHC	111.5	134.1	156.8	107.3	129.1	151.0	102.8	123.7	144.6	97.9	117.8	137.7	92.6	111.5	130.3	
	67		TC	141.2	141.2	144.6	134.9	134.9	141.7	128.7	128.7	136.4	121.7	121.7	132.7	114.2	114.2	128.2	
			SHC	91.4	118.0	144.6	88.9	115.3	141.7	85.2	110.8	136.4	82.1	107.4	132.7	78.6	103.4	128.2	
	72	TC	153.9	153.9	153.9	147.0	147.0	147.0	139.6	139.6	139.6	131.8	131.8	131.8	123.5	123.5	123.5		
		SHC	62.7	88.8	115.0	60.4	86.5	112.7	57.9	84.1	110.3	55.3	81.5	107.8	52.6	78.8	105.1		
	76	TC	—	164.0	164.0	—	156.6	156.6	—	148.7	148.7	—	140.2	140.2	—	131.4	131.4		
		SHC	—	65.2	90.0	—	63.0	87.9	—	60.6	85.6	—	57.9	83.1	—	55.2	80.4		

LEGEND

- db — dry bulb
- EA — Entering Air Temperature (°F)
- SHC — Sensible Heat Capacity (1000 Btuh) gross
- TC — Total Capacity (1000 Btuh) gross
- wb — wet bulb

38AXD14/40RLA14 Stage 1 Combination Ratings — 60 Hz

38AXD14/40RLA14			AMBIENT TEMPERATURE (°F)																
			85			95			105			115			125				
			EA (db)			EA (db)			EA (db)			EA (db)			EA (db)				
			75	80	85	75	80	85	75	80	85	75	80	85	75	80	85		
3150 cfm	EA (wb)	58	TC	48.8	48.8	58.5	46.2	46.2	56.7	44.2	44.2	51.8	42.8	42.8	53.5	40.5	40.5	48.0	
		58	SHC	39.2	48.8	58.5	35.6	46.2	56.7	36.7	44.2	51.8	32.2	42.8	53.5	33.0	40.5	48.0	
		62	TC	50.3	50.3	60.4	48.0	48.0	58.8	44.2	44.2	54.9	44.2	44.2	54.4	40.5	40.5	50.2	
		62	SHC	36.1	48.2	60.4	32.8	45.8	58.8	33.6	44.2	54.9	28.8	41.6	54.4	30.7	40.5	50.2	
		67	TC	55.3	55.3	55.3	53.0	53.0	53.0	50.4	50.4	51.6	47.1	47.1	53.0	44.3	44.3	49.4	
		67	SHC	24.3	38.7	53.0	23.9	38.4	53.0	22.3	37.0	51.6	18.9	36.0	53.0	20.3	34.9	49.4	
	72	TC	60.5	60.5	60.5	57.8	57.8	57.8	55.3	55.3	55.3	52.1	52.1	52.1	48.5	48.5	48.5		
	72	SHC	16.9	30.6	44.3	16.0	30.0	43.9	14.5	28.9	43.3	13.5	27.8	42.0	12.3	26.8	41.3		
	76	TC	—	64.2	64.2	—	61.6	61.6	—	59.0	59.0	—	56.0	56.0	—	51.9	51.9		
	76	SHC	—	23.7	36.6	—	23.0	37.0	—	22.2	35.4	—	21.3	34.7	—	20.0	34.1		
	3750 cfm	EA (wb)	58	TC	52.3	52.3	62.8	48.2	48.2	59.5	47.0	47.0	57.4	44.9	44.9	53.2	43.1	43.1	53.9
			58	SHC	41.9	52.3	62.8	36.9	48.2	59.5	36.6	47.0	57.4	36.5	44.9	53.2	32.4	43.1	53.9
62			TC	52.3	52.3	66.2	48.8	48.8	62.7	47.0	47.0	60.9	44.7	44.7	60.0	43.0	43.0	53.7	
62			SHC	38.5	52.3	66.2	34.7	48.7	62.7	33.1	47.0	60.9	29.4	44.7	60.0	32.2	43.0	53.7	
67			TC	56.2	56.2	56.2	54.1	54.1	58.2	52.4	52.4	55.1	49.5	49.5	58.0	45.5	45.5	55.6	
67			SHC	27.8	41.6	55.5	24.3	41.3	58.2	27.2	41.1	55.1	23.0	40.5	58.0	21.1	38.3	55.6	
72		TC	61.9	61.9	61.9	59.3	59.3	59.3	56.5	56.5	56.5	53.3	53.3	53.3	49.7	49.7	49.7		
72		SHC	16.5	32.7	48.8	15.4	31.8	48.1	13.9	30.7	47.6	12.7	29.6	46.6	11.5	28.5	45.5		
76		TC	—	61.9	61.9	—	63.8	63.8	—	60.0	60.0	—	56.7	56.7	—	52.7	52.7		
76		SHC	—	32.7	47.9	—	24.0	39.8	—	22.9	39.8	—	21.9	38.1	—	20.7	37.0		
4400 cfm		EA (wb)	58	TC	52.4	52.4	63.9	50.8	50.8	62.4	48.7	48.7	59.7	47.0	47.0	58.6	44.1	44.1	55.1
			58	SHC	40.9	52.4	63.9	39.2	50.8	62.4	37.7	48.7	59.7	35.4	47.0	58.6	33.0	44.1	55.1
	62		TC	54.1	54.1	66.3	52.2	52.2	65.8	49.8	49.8	64.7	46.7	46.7	62.3	44.6	44.6	55.7	
	62		SHC	35.4	50.9	66.3	35.0	50.4	65.8	34.9	49.8	64.7	31.2	46.7	62.3	33.5	44.6	55.7	
	67		TC	57.7	57.7	65.4	54.9	54.9	60.6	52.3	52.3	58.6	49.2	49.2	62.4	46.0	46.0	60.6	
	67		SHC	26.3	45.8	65.4	29.7	45.1	60.6	28.8	43.7	58.6	23.1	42.8	62.4	20.9	40.8	60.6	
	72	TC	63.3	63.3	63.3	60.3	60.3	60.3	57.3	57.3	57.3	54.1	54.1	54.1	50.9	50.9	50.9		
	72	SHC	15.6	34.5	53.3	14.7	33.6	52.6	13.2	32.6	52.1	11.7	31.5	51.2	11.1	30.5	49.8		
	76	TC	—	63.3	63.3	—	64.1	64.1	—	60.5	60.5	—	57.7	57.7	—	53.8	53.8		
	76	SHC	—	34.5	53.3	—	24.5	42.3	—	23.3	41.9	—	22.5	41.0	—	21.3	39.7		
	5000 cfm	EA (wb)	58	TC	54.3	54.3	66.8	52.1	52.1	64.7	50.5	50.5	62.5	47.8	47.8	59.9	45.1	45.1	56.5
			58	SHC	41.9	54.3	66.8	39.5	52.1	64.7	38.6	50.5	62.5	35.8	47.8	59.9	33.8	45.1	56.5
62			TC	54.8	54.8	71.5	52.7	52.7	69.3	50.3	50.3	66.6	47.9	47.9	63.8	45.3	45.3	60.6	
62			SHC	38.0	54.8	71.5	36.0	52.6	69.3	34.0	50.3	66.6	32.0	47.9	63.8	30.0	45.3	60.6	
67			TC	58.5	58.5	71.2	55.8	55.8	69.8	52.9	52.9	62.6	49.9	49.9	66.6	45.3	45.3	66.8	
67			SHC	27.9	49.6	71.2	26.1	48.0	69.8	31.4	47.0	62.6	23.2	44.9	66.6	23.8	45.3	66.8	
72		TC	64.1	64.1	64.1	61.3	61.3	61.3	58.1	58.1	58.1	54.7	54.7	54.8	51.0	51.0	53.0		
72		SHC	15.0	36.1	57.2	13.7	35.1	56.5	13.1	34.2	55.2	11.5	33.2	54.8	10.9	31.9	53.0		
76		TC	—	68.6	68.6	—	65.4	65.4	—	62.1	62.1	—	58.5	58.5	—	54.6	54.6		
76		SHC	—	25.9	42.7	—	24.8	45.1	—	23.8	44.5	—	22.8	43.4	—	21.6	42.0		
5650 cfm		EA (wb)	58	TC	56.0	56.0	79.7	54.2	54.2	81.2	51.6	51.6	79.0	49.2	49.2	61.4	46.2	46.2	54.7
			58	SHC	32.2	56.0	79.7	27.1	54.2	81.2	24.2	51.6	79.0	37.0	49.2	61.4	37.6	46.2	54.7
	62		TC	55.7	55.7	82.8	54.1	54.1	81.3	52.5	52.5	78.7	49.2	49.2	65.6	46.2	46.2	61.6	
	62		SHC	28.7	55.7	82.8	26.9	54.1	81.3	26.2	52.4	78.7	32.8	49.2	65.6	30.8	46.2	61.6	
	67		TC	55.7	55.7	79.8	54.1	54.1	80.2	53.8	53.8	73.9	51.6	51.6	68.0	46.4	46.4	61.7	
	67		SHC	31.7	55.7	79.8	28.0	54.1	80.2	24.8	49.3	73.9	19.3	43.6	68.0	31.1	46.4	61.7	
	72	TC	64.8	64.8	68.7	61.9	61.9	67.8	53.8	53.8	73.9	55.3	55.3	58.5	51.5	51.5	57.1		
	72	SHC	6.6	37.6	68.7	5.7	36.7	67.8	24.8	49.3	73.9	10.7	34.6	58.5	9.3	33.2	57.1		
	76	TC	—	69.4	69.4	—	66.2	66.2	—	62.8	62.8	—	58.9	58.9	—	54.8	54.8		
	76	SHC	—	26.1	57.2	—	25.1	56.2	—	24.1	47.0	—	22.9	45.8	—	21.6	44.3		

LEGEND

- db — dry bulb
- EA — Entering Air Temperature (°F)
- SHC — Sensible Heat Capacity (1000 Btuh) gross
- TC — Total Capacity (1000 Btuh) gross
- wb — wet bulb

38AXZ16/40RLA16 Stage 2 Combination Ratings — 60 Hz

38AXZ16/40RLA16			AMBIENT TEMPERATURE (°F)																
			85			95			105			115			125				
			EA (db)			EA (db)			EA (db)			EA (db)			EA (db)				
			75	80	85	75	80	85	75	80	85	75	80	85	75	80	85		
4500 cfm	EA (wb)	58	TC	171.1	171.1	182.3	165.0	165.0	179.9	159.7	159.7	171.4	152.2	152.2	171.5	145.4	145.4	163.9	
			SHC	143.3	162.8	182.3	140.6	160.2	179.9	134.5	153.0	171.4	132.9	152.2	171.5	127.0	145.4	163.9	
		62	TC	184.1	184.1	184.1	176.8	176.8	177.2	169.0	169.0	173.4	158.2	158.2	164.6	149.6	149.6	160.7	
			SHC	134.7	157.7	180.7	131.2	154.2	177.2	127.6	150.5	173.4	120.6	142.6	164.6	116.7	138.7	160.7	
		67	TC	197.8	197.8	197.8	190.2	190.2	190.2	184.5	184.5	184.5	173.1	173.1	173.1	163.4	163.4	163.4	
			SHC	107.7	129.1	150.4	104.6	126.1	147.6	103.8	126.9	149.9	97.6	119.4	141.2	93.8	115.6	137.5	
	72	TC	216.0	216.0	216.0	207.7	207.7	207.7	198.5	198.5	198.5	188.7	188.7	188.7	178.2	178.2	178.2		
		SHC	85.1	105.2	125.3	81.7	102.2	122.7	78.1	99.0	119.8	74.3	95.4	116.5	70.4	91.7	113.0		
	76	TC	—	232.0	232.0	—	225.4	225.4	—	212.9	212.9	—	202.1	202.1	—	190.6	190.6		
		SHC	—	85.0	109.7	—	86.7	111.3	—	79.1	103.8	—	76.0	100.7	—	72.5	91.5		
	5250 cfm	EA (wb)	58	TC	179.5	179.5	190.4	172.2	172.2	194.1	166.1	166.1	187.2	159.4	159.4	179.7	152.1	152.1	171.4
				SHC	149.7	170.1	190.4	150.3	172.2	194.1	145.0	166.1	187.2	139.1	159.4	179.7	132.8	152.1	171.4
62			TC	185.7	185.7	189.8	181.7	181.7	193.1	170.8	170.8	183.3	162.3	162.3	179.0	153.6	153.6	174.0	
			SHC	139.6	164.7	189.8	140.5	166.8	193.1	133.1	158.2	183.3	129.0	154.0	179.0	124.6	149.3	174.0	
67			TC	203.2	203.2	203.2	195.2	195.2	195.2	186.4	186.4	186.4	177.0	177.0	177.0	166.9	166.9	166.9	
			SHC	113.3	138.2	163.0	110.1	135.1	160.1	106.7	131.7	156.7	103.0	128.1	153.3	99.1	124.3	149.5	
72		TC	221.6	221.6	221.6	212.8	212.8	212.8	203.2	203.2	203.2	192.8	192.8	192.8	181.8	181.8	181.8		
		SHC	86.8	110.5	134.3	83.4	107.4	131.5	79.8	104.1	128.4	76.0	100.5	124.9	72.1	96.7	121.3		
76		TC	—	237.5	237.5	—	227.6	227.6	—	217.2	217.2	—	206.1	206.1	—	194.2	194.2		
		SHC	—	87.8	116.7	—	85.0	113.9	—	81.8	102.8	—	78.4	101.0	—	74.7	98.2		
6000 cfm		EA (wb)	58	TC	185.1	185.1	208.7	179.1	179.1	201.9	172.5	172.5	194.5	165.4	165.4	186.5	157.6	157.6	177.7
				SHC	161.5	185.1	208.7	156.3	179.1	201.9	150.6	172.5	194.5	144.3	165.4	186.5	137.5	157.6	177.7
	62		TC	189.9	189.9	204.2	182.5	182.5	200.6	174.6	174.6	195.8	166.3	166.3	189.8	158.4	158.4	179.3	
			SHC	148.0	176.1	204.2	144.6	172.6	200.6	140.4	168.1	195.8	135.6	162.7	189.8	128.4	153.8	179.3	
	67		TC	207.3	207.3	207.3	198.9	198.9	198.9	189.8	189.8	189.8	180.0	180.0	180.0	169.5	169.5	169.5	
			SHC	118.5	146.6	174.7	115.3	143.6	171.8	111.9	140.2	168.5	108.2	136.6	165.0	104.3	132.7	161.2	
	72	TC	226.0	226.0	226.0	216.7	216.7	216.7	206.7	206.7	206.7	196.0	196.0	196.0	184.6	184.6	184.6		
		SHC	88.3	115.4	142.6	84.9	112.3	139.6	81.3	108.8	136.4	77.5	105.2	132.9	73.5	101.3	129.1		
	76	TC	—	245.4	245.4	—	235.0	235.0	—	220.8	220.8	—	209.2	209.2	—	197.0	197.0		
		SHC	—	94.8	125.7	—	91.3	122.0	—	84.0	109.8	—	80.4	106.8	—	76.6	103.5		
	6750 cfm	EA (wb)	58	TC	191.2	191.2	215.6	184.9	184.9	208.5	177.9	177.9	200.6	170.3	170.3	192.1	162.1	162.1	182.8
				SHC	166.8	191.2	215.6	161.3	184.9	208.5	155.2	177.9	200.6	148.6	170.3	192.1	141.4	162.1	182.8
62			TC	193.8	193.8	216.3	186.2	186.2	211.4	179.9	179.9	192.5	171.5	171.5	191.7	164.6	164.6	171.7	
			SHC	155.3	185.8	216.3	151.1	181.2	211.4	139.6	166.1	192.5	137.5	164.6	191.7	125.4	148.5	171.7	
67			TC	214.1	214.1	214.1	201.9	201.9	201.9	192.5	192.5	192.5	182.4	182.4	182.4	171.6	171.6	172.8	
			SHC	127.4	160.5	193.6	120.4	151.8	183.3	116.9	148.4	179.9	113.2	144.8	176.4	109.5	141.1	172.8	
72		TC	229.4	229.4	229.4	219.8	219.8	219.8	209.5	209.5	209.5	198.5	198.5	198.5	186.8	186.8	186.8		
		SHC	89.6	120.0	150.4	86.3	116.8	147.3	82.7	113.3	144.0	78.9	109.7	140.5	74.9	105.8	136.7		
76		TC	—	245.1	245.1	—	234.6	234.6	—	223.5	223.5	—	211.6	211.6	—	199.1	199.1		
		SHC	—	92.3	120.4	—	89.2	118.0	—	85.7	115.1	—	82.1	111.8	—	78.2	108.2		
7500 cfm		EA (wb)	58	TC	196.5	196.5	221.6	189.8	189.8	214.1	182.5	182.5	205.8	174.5	174.5	196.8	165.9	165.9	187.1
				SHC	171.4	196.5	221.6	165.6	189.8	214.1	159.2	182.5	205.8	152.2	174.5	196.8	144.7	165.9	187.1
	62		TC	197.6	197.6	225.0	190.6	190.6	218.0	183.6	183.6	206.8	176.5	176.5	190.3	166.1	166.1	194.3	
			SHC	160.7	192.9	225.0	155.5	186.7	218.0	148.0	177.4	206.8	137.6	163.9	190.3	137.9	166.1	194.3	
	67		TC	216.8	216.8	216.8	204.3	204.3	204.3	194.6	194.6	194.6	184.3	184.3	187.7	173.2	173.2	183.2	
			SHC	132.5	168.8	205.0	125.3	159.9	194.4	121.9	156.5	191.1	118.3	153.0	187.7	114.1	148.7	183.2	
	72	TC	232.2	232.2	232.2	222.3	222.3	222.3	211.8	211.8	211.8	200.5	200.5	200.5	188.6	188.6	188.6		
		SHC	90.9	124.4	157.9	87.5	121.1	154.8	83.9	117.7	151.4	80.1	113.9	147.8	76.2	110.0	143.9		
	76	TC	—	247.8	247.8	—	237.2	237.2	—	225.8	225.8	—	213.6	213.6	—	200.9	200.9		
		SHC	—	94.0	125.7	—	90.7	122.9	—	87.2	119.8	—	83.5	116.3	—	79.6	112.5		

LEGEND

- db — dry bulb
- EA — Entering Air Temperature (°F)
- SHC — Sensible Heat Capacity (1000 Btuh) gross
- TC — Total Capacity (1000 Btuh) gross
- wb — wet bulb

38AXZ16/40RLA16 Stage 1 Combination Ratings — 60 Hz

38AXZ16/40RLA16				AMBIENT TEMPERATURE (°F)															
				85			95			105			115			125			
				EA (db)			EA (db)			EA (db)			EA (db)			EA (db)			
				75	80	85	75	80	85	75	80	85	75	80	85	75	80	85	
3750 cfm	EA (wb)	58	TC	109.9	109.9	124.3	106.1	106.1	120.0	101.9	101.9	115.3	97.5	97.5	110.2	92.5	92.5	104.6	
			SHC	95.5	109.9	124.3	92.2	106.1	120.0	88.5	101.9	115.3	84.7	97.5	110.2	80.4	92.5	104.6	
		62	TC	110.1	110.1	129.2	106.2	106.2	124.7	102.0	102.0	119.8	97.5	97.5	114.5	92.3	92.3	108.7	
			SHC	90.9	110.1	129.2	87.7	106.2	124.7	84.2	102.0	119.8	80.5	97.5	114.5	76.0	92.3	108.7	
		67	TC	119.2	119.2	119.2	114.1	114.1	114.1	108.6	108.6	109.1	102.7	102.7	106.9	96.3	96.3	104.5	
			SHC	72.6	92.9	113.2	70.6	90.9	111.2	68.6	88.8	109.1	66.4	86.6	106.9	64.1	84.3	104.5	
	72	TC	131.2	131.2	131.2	125.5	125.5	125.5	119.4	119.4	119.4	113.0	113.0	113.0	106.0	106.0	106.0		
		SHC	52.2	72.6	93.0	50.3	70.6	91.0	48.2	68.6	88.9	46.0	66.4	86.7	43.7	64.1	84.4		
	76	TC	—	141.3	141.3	—	135.1	135.1	—	128.6	128.6	—	121.7	121.7	—	114.2	114.2		
		SHC	—	56.1	76.6	—	54.1	74.6	—	52.0	72.5	—	49.8	70.2	—	47.5	67.7		
	4500 cfm	EA (wb)	58	TC	116.1	116.1	131.3	111.9	111.9	126.5	107.3	107.3	121.3	102.4	102.4	115.8	97.0	97.0	109.7
				SHC	100.9	116.1	131.3	97.2	111.9	126.5	93.3	107.3	121.3	89.0	102.4	115.8	84.3	97.0	109.7
62			TC	116.2	116.2	136.4	111.9	111.9	131.4	107.4	107.4	126.1	102.5	102.5	120.3	97.1	97.1	114.0	
			SHC	96.0	116.2	136.4	92.4	111.9	131.4	88.8	107.4	126.1	84.7	102.5	120.3	80.2	97.1	114.0	
67			TC	122.1	122.1	127.5	116.7	116.7	125.4	111.0	111.0	123.2	104.9	104.9	120.8	98.5	98.5	118.1	
			SHC	79.2	103.3	127.5	77.2	101.3	125.4	75.1	99.1	123.2	72.8	96.8	120.8	70.4	94.3	118.1	
72		TC	134.1	134.1	134.1	128.2	128.2	128.2	121.8	121.8	121.8	115.1	115.1	115.1	107.9	107.9	107.9		
		SHC	54.7	78.9	103.2	52.7	76.9	101.2	50.6	74.8	99.1	48.4	72.6	96.8	46.1	70.3	94.4		
76		TC	—	144.3	144.3	—	137.9	137.9	—	131.1	131.1	—	123.8	123.8	—	116.1	116.1		
		SHC	—	59.0	83.3	—	57.0	81.2	—	54.8	79.0	—	52.6	76.6	—	50.2	74.0		
5250 cfm		EA (wb)	58	TC	121.0	121.0	136.8	116.4	116.4	131.6	111.6	111.6	126.1	106.3	106.3	120.2	100.6	100.6	113.7
				SHC	105.2	121.0	136.8	101.2	116.4	131.6	97.0	111.6	126.1	92.4	106.3	120.2	87.4	100.6	113.7
	62		TC	121.1	121.1	142.1	116.5	116.5	136.7	111.6	111.6	131.0	106.4	106.4	124.8	100.7	100.7	118.1	
			SHC	100.1	121.1	142.1	96.3	116.5	136.7	92.3	111.6	131.0	87.9	106.4	124.8	83.2	100.7	118.1	
	67		TC	124.3	124.3	141.1	118.8	118.8	138.8	112.9	112.9	136.2	106.8	106.8	133.1	100.9	100.9	127.0	
			SHC	85.5	113.3	141.1	83.4	111.1	138.8	81.1	108.7	136.2	78.6	105.8	133.1	74.8	100.9	127.0	
	72	TC	136.2	136.2	136.2	130.0	130.0	130.0	123.5	123.5	123.5	116.6	116.6	116.6	109.3	109.3	109.3		
		SHC	56.9	85.0	113.0	54.9	82.9	111.0	52.8	80.8	108.8	50.6	78.6	106.5	48.4	76.3	104.2		
	76	TC	—	146.4	146.4	—	139.7	139.7	—	132.7	132.7	—	125.2	125.2	—	117.3	117.3		
		SHC	—	61.6	89.5	—	59.5	87.3	—	57.3	84.9	—	54.9	82.3	—	52.4	79.4		
	6000 cfm	EA (wb)	58	TC	125.1	125.1	141.4	120.3	120.3	135.9	115.0	115.0	130.0	109.5	109.5	123.8	103.4	103.4	116.9
				SHC	108.8	125.1	141.4	104.6	120.3	135.9	100.1	115.0	130.0	95.3	109.5	123.8	89.9	103.4	116.9
62			TC	125.0	125.0	146.7	120.2	120.2	141.0	115.0	115.0	135.0	109.5	109.5	128.4	103.5	103.5	121.4	
			SHC	103.4	125.0	146.7	99.4	120.2	141.0	95.1	115.0	135.0	90.5	109.5	128.4	85.5	103.5	121.4	
67			TC	126.2	126.2	153.6	120.6	120.6	150.5	115.5	115.5	143.0	109.6	109.6	137.9	103.7	103.7	130.5	
			SHC	91.3	122.5	153.6	88.9	119.7	150.5	84.6	113.8	143.0	81.3	109.6	137.9	76.9	103.7	130.5	
72		TC	137.7	137.7	137.7	131.4	131.4	131.4	124.7	124.7	124.7	117.6	117.6	117.6	110.1	110.1	113.6		
		SHC	59.0	90.8	122.6	57.0	88.8	120.5	55.0	86.7	118.3	52.8	84.4	116.0	50.5	82.0	113.6		
76		TC	—	147.8	147.8	—	141.0	141.0	—	133.8	133.8	—	126.2	126.2	—	118.1	118.1		
		SHC	—	63.8	95.1	—	61.7	92.8	—	59.4	90.2	—	56.9	87.4	—	54.2	84.2		
6750 cfm		EA (wb)	58	TC	128.2	128.2	144.9	123.1	123.1	139.2	117.7	117.7	133.1	112.0	112.0	126.5	105.7	105.7	119.4
				SHC	111.5	128.2	144.9	107.1	123.1	139.2	102.4	117.7	133.1	97.4	112.0	126.5	91.9	105.7	119.4
	62		TC	128.3	128.3	150.5	123.2	123.2	144.5	117.8	117.8	138.2	112.0	112.0	131.4	105.7	105.7	124.0	
			SHC	106.1	128.3	150.5	101.9	123.2	144.5	97.5	117.8	138.2	92.7	112.0	131.4	87.5	105.7	124.0	
	67		TC	128.4	128.4	161.5	123.4	123.4	155.2	118.0	118.0	148.4	112.1	112.1	141.1	105.9	105.9	133.2	
			SHC	95.3	128.4	161.5	91.5	123.4	155.2	87.5	118.0	148.4	83.2	112.1	141.1	78.6	105.9	133.2	
	72	TC	138.9	138.9	138.9	132.4	132.4	132.4	125.6	125.6	127.6	118.4	118.4	125.3	110.8	110.8	122.8		
		SHC	61.1	96.5	131.9	59.1	94.5	129.9	57.1	92.3	127.6	54.9	90.1	125.3	52.7	87.7	122.8		
	76	TC	—	148.9	148.9	—	141.9	141.9	—	134.6	134.6	—	126.8	126.8	—	118.6	118.6		
		SHC	—	65.8	100.4	—	63.6	97.8	—	61.2	95.0	—	58.6	91.9	—	55.7	88.4		

LEGEND

- db — dry bulb
- EA — Entering Air Temperature (°F)
- SHC — Sensible Heat Capacity (1000 Btuh) gross
- TC — Total Capacity (1000 Btuh) gross
- wb — wet bulb

38AXD16/40RLA16 Stage 3 Combination Ratings — 60 Hz

38AXD16/40RLA16				AMBIENT TEMPERATURE (°F)															
				85			95			105			115			125			
				EA (db)			EA (db)			EA (db)			EA (db)			EA (db)			
				75	80	85	75	80	85	75	80	85	75	80	85	75	80	85	
4500 cfm	EA (wb)	58	TC	172.0	172.0	194.6	166.4	166.4	188.1	160.5	160.5	181.6	154.0	154.0	174.3	147.0	147.0	166.3	
			SHC	149.3	172.0	194.6	144.4	166.3	188.1	139.4	160.5	181.6	133.8	154.0	174.3	127.7	147.0	166.3	
		62	TC	184.1	184.1	184.1	176.8	176.8	176.8	168.9	168.9	172.8	160.4	160.4	168.8	151.3	151.3	164.4	
			SHC	132.8	156.4	179.9	129.3	152.9	176.4	125.7	149.3	172.8	121.9	145.3	168.8	117.7	141.1	164.4	
		67	TC	203.2	203.2	203.2	195.1	195.1	195.1	186.3	186.3	186.3	176.9	176.9	176.9	166.8	166.8	166.8	
			SHC	109.5	133.2	156.8	106.1	129.7	153.4	102.5	126.1	149.7	98.6	122.2	145.8	94.6	118.2	141.7	
	72	TC	223.9	223.9	223.9	214.9	214.9	214.9	205.3	205.3	205.3	194.9	194.9	194.9	183.9	183.9	183.9		
		SHC	85.8	109.7	133.6	82.4	106.2	130.0	78.7	102.5	126.3	74.9	98.6	122.3	70.8	94.5	118.2		
	76	TC	—	241.7	241.7	—	231.9	231.9	—	221.4	221.4	—	210.2	210.2	—	198.3	198.3		
		SHC	—	90.4	115.2	—	87.0	111.8	—	83.4	108.1	—	79.5	104.0	—	75.4	99.7		
	5350 cfm	EA (wb)	58	TC	182.1	182.1	206.0	176.2	176.2	199.2	169.7	169.7	191.9	162.6	162.6	183.9	154.9	154.9	175.2
				SHC	158.3	182.1	206.0	153.1	176.2	199.2	147.5	169.7	191.9	141.3	162.6	183.9	134.6	154.9	175.2
62			TC	190.5	190.5	197.6	182.7	182.7	193.9	174.4	174.4	189.9	165.5	165.5	185.4	156.4	156.4	179.0	
			SHC	143.4	170.5	197.6	139.8	166.9	193.9	136.0	162.9	189.9	131.8	158.6	185.4	126.6	152.8	179.0	
67			TC	209.8	209.8	209.8	201.1	201.1	201.1	191.8	191.8	191.8	181.8	181.8	181.8	171.2	171.2	171.2	
			SHC	116.3	143.5	170.8	112.8	140.0	167.3	109.0	136.3	163.5	105.1	132.3	159.5	101.0	128.1	155.3	
72		TC	230.8	230.8	230.8	221.3	221.3	221.3	211.1	211.1	211.1	199.9	199.9	199.9	188.5	188.5	188.5		
		SHC	88.6	116.0	143.5	85.0	112.5	139.9	81.3	108.7	136.0	77.3	104.7	132.0	73.3	100.5	127.8		
76		TC	—	248.8	248.8	—	238.5	238.5	—	227.4	227.4	—	215.5	215.5	—	203.0	203.0		
		SHC	—	93.8	122.2	—	90.2	118.4	—	86.4	114.5	—	82.4	110.3	—	78.2	106.0		
6000 cfm		EA (wb)	58	TC	190.8	190.8	215.8	184.4	184.4	208.5	177.4	177.4	200.5	169.8	169.8	192.0	161.5	161.5	182.6
				SHC	165.9	190.8	215.8	160.3	184.4	208.5	154.2	177.4	200.5	147.6	169.8	192.0	140.4	161.5	182.6
	62		TC	195.8	195.8	214.1	187.7	187.7	210.0	179.0	179.0	205.7	170.6	170.6	197.9	161.7	161.7	189.8	
			SHC	153.3	183.7	214.1	149.5	179.7	210.0	145.5	175.6	205.7	139.6	168.8	197.9	133.6	161.7	189.8	
	67		TC	214.9	214.9	214.9	205.8	205.8	205.8	196.1	196.1	196.1	185.6	185.6	185.6	174.5	174.5	174.5	
			SHC	122.6	153.4	184.2	119.0	149.8	180.6	115.2	146.0	176.8	111.2	142.0	172.7	107.1	137.8	168.4	
	72	TC	236.3	236.3	236.3	226.3	226.3	226.3	215.6	215.6	215.6	204.1	204.1	204.1	192.1	192.1	192.1		
		SHC	91.0	121.9	152.9	87.4	118.3	149.2	83.5	114.4	145.3	79.5	110.3	141.1	75.4	106.1	136.8		
	76	TC	—	254.4	254.4	—	243.5	243.5	—	231.9	231.9	—	219.5	219.5	—	206.5	206.5		
		SHC	—	96.5	128.2	—	92.8	124.4	—	89.0	120.4	—	84.9	116.1	—	80.6	111.7		
	6750 cfm	EA (wb)	58	TC	198.2	198.2	224.1	191.3	191.3	216.3	183.9	183.9	207.8	175.8	175.8	198.7	167.1	167.1	188.9
				SHC	172.4	198.2	224.1	166.4	191.3	216.3	159.9	183.9	207.8	152.9	175.8	198.7	145.3	167.1	188.9
62			TC	200.4	200.4	228.9	192.5	192.5	222.5	184.2	184.2	216.2	175.9	175.9	206.5	167.2	167.2	196.2	
			SHC	162.2	195.6	228.9	157.2	189.9	222.5	152.2	184.2	216.2	145.4	175.9	206.5	138.2	167.2	196.2	
67			TC	219.0	219.0	219.0	209.5	209.5	209.5	199.4	199.4	199.4	188.6	188.6	188.6	177.2	177.2	181.0	
			SHC	128.6	162.9	197.2	125.0	159.2	193.5	121.2	155.4	189.6	117.1	151.3	185.4	112.9	147.0	181.0	
72		TC	240.6	240.6	240.6	230.2	230.2	230.2	219.1	219.1	219.1	207.3	207.3	207.3	194.9	194.9	194.9		
		SHC	93.0	127.4	161.8	89.4	123.7	158.1	85.5	119.8	154.1	81.5	115.7	149.9	77.3	111.4	145.5		
76		TC	—	258.8	258.8	—	247.5	247.5	—	235.4	235.4	—	222.7	222.7	—	209.3	209.3		
		SHC	—	98.8	133.9	—	95.1	130.0	—	91.2	125.9	—	87.0	121.5	—	82.7	117.0		
7500 cfm		EA (wb)	58	TC	204.6	204.6	231.2	197.3	197.3	222.9	189.4	189.4	214.1	180.9	180.9	204.4	171.8	171.8	194.1
				SHC	177.9	204.6	231.2	171.6	197.3	222.9	164.8	189.4	214.1	157.4	180.9	204.4	149.4	171.8	194.1
	62		TC	205.0	205.0	240.5	197.5	197.5	231.6	189.6	189.6	222.4	181.1	181.1	212.4	171.9	171.9	201.7	
			SHC	169.5	205.0	240.5	163.3	197.5	231.6	156.8	189.6	222.4	149.7	181.1	212.4	142.1	171.9	201.7	
	67		TC	222.3	222.3	222.3	212.5	212.5	212.5	202.1	202.1	202.1	191.0	191.0	197.7	179.4	179.4	193.1	
			SHC	134.4	172.1	209.8	130.8	168.4	206.0	126.9	164.5	202.0	122.8	160.3	197.7	118.5	155.8	193.1	
	72	TC	244.2	244.2	244.2	233.4	233.4	233.4	222.0	222.0	222.0	209.8	209.8	209.8	197.1	197.1	197.1		
		SHC	94.9	132.6	170.4	91.2	128.8	166.5	87.3	124.9	162.5	83.2	120.7	158.3	79.0	116.4	153.9		
	76	TC	—	262.3	262.3	—	250.7	250.7	—	238.3	238.3	—	225.2	225.2	—	211.5	211.5		
		SHC	—	100.9	139.2	—	97.1	135.2	—	93.1	131.0	—	88.8	126.5	—	84.4	121.9		

LEGEND

- db — dry bulb
- EA — Entering Air Temperature (°F)
- SHC — Sensible Heat Capacity (1000 Btuh) gross
- TC — Total Capacity (1000 Btuh) gross
- wb — wet bulb

38AXD16/40RLA16 Stage 2 Combination Ratings — 60 Hz

38AXD16/40RLA16			AMBIENT TEMPERATURE (°F)																
			85			95			105			115			125				
			EA (db)			EA (db)			EA (db)			EA (db)			EA (db)				
			75	80	85	75	80	85	75	80	85	75	80	85	75	80	85		
3750 cfm	EA (wb)	58	TC	147.8	147.8	161.1	142.4	142.4	156.7	136.6	136.6	152.2	130.2	130.2	147.1	123.3	123.3	139.3	
			SHC	125.0	143.1	161.1	121.3	139.0	156.7	117.4	134.8	152.2	113.3	130.2	147.1	107.2	123.3	139.3	
		62	TC	155.9	155.9	155.9	149.3	149.3	151.4	142.5	142.5	146.8	135.6	135.6	141.4	128.3	128.3	135.8	
			SHC	114.2	134.3	154.5	111.1	131.3	151.4	107.2	127.0	146.8	102.8	122.1	141.4	98.3	117.0	135.8	
		67	TC	172.5	172.5	172.5	165.5	165.5	165.5	157.8	157.8	157.8	149.5	149.5	149.5	140.6	140.6	140.6	
			SHC	94.5	114.7	134.9	91.5	111.7	131.9	88.3	108.5	128.7	84.9	105.1	125.3	81.3	101.5	121.7	
	72	TC	190.4	190.4	190.4	182.8	182.8	182.8	174.5	174.5	174.5	165.6	165.6	165.6	155.9	155.9	155.9		
		SHC	74.4	94.8	115.2	71.4	91.8	112.2	68.2	88.5	108.7	64.9	85.2	105.6	61.3	81.7	102.0		
	76	TC	—	205.7	205.7	—	197.5	197.5	—	188.8	188.8	—	179.2	179.2	—	168.8	168.8		
		SHC	—	78.2	98.8	—	75.3	95.9	—	72.2	92.8	—	68.9	89.5	—	65.4	86.0		
	4500 cfm	EA (wb)	58	TC	156.8	156.8	177.1	151.1	151.1	170.7	145.2	145.2	164.0	139.2	139.2	157.2	132.1	132.1	149.2
				SHC	136.4	156.8	177.1	131.5	151.1	170.7	126.4	145.2	164.0	121.1	139.2	157.2	114.9	132.1	149.2
62			TC	163.1	163.1	169.9	156.6	156.6	164.8	150.1	150.1	159.9	142.5	142.5	154.0	134.7	134.7	148.2	
			SHC	123.7	146.8	169.9	119.5	142.2	164.8	115.5	137.7	159.9	110.6	132.3	154.0	105.9	127.0	148.2	
67			TC	179.4	179.4	179.4	171.8	171.8	171.8	163.6	163.6	163.6	154.8	154.8	154.8	145.2	145.2	145.2	
			SHC	101.7	125.8	149.9	98.6	122.7	146.7	95.3	119.4	143.4	91.8	115.9	139.9	88.1	112.1	136.2	
72		TC	197.8	197.8	197.8	189.5	189.5	189.5	180.7	180.7	180.7	171.1	171.1	171.1	160.9	160.9	160.9		
		SHC	77.3	101.6	125.9	74.3	98.6	122.9	71.1	95.3	119.5	67.6	91.8	116.0	64.0	88.2	112.4		
76		TC	—	213.4	213.4	—	204.6	204.6	—	195.0	195.0	—	184.8	184.8	—	173.8	173.8		
		SHC	—	81.9	106.6	—	78.9	103.6	—	75.7	100.4	—	72.2	96.9	—	68.6	93.2		
5250 cfm		EA (wb)	58	TC	165.5	165.5	187.0	159.7	159.7	180.4	153.3	153.3	173.2	146.5	146.5	165.4	138.6	138.6	156.5
				SHC	144.1	165.5	187.0	139.0	159.7	180.4	133.5	153.3	173.2	127.5	146.5	165.4	120.6	138.6	156.5
	62		TC	170.0	170.0	182.4	163.0	163.0	176.9	155.7	155.7	171.4	148.1	148.1	165.9	139.1	139.1	158.8	
			SHC	131.4	156.9	182.4	127.0	152.0	176.9	122.5	147.0	171.4	118.0	142.0	165.9	112.5	135.6	158.8	
	67		TC	184.4	184.4	184.4	176.4	176.4	176.4	167.8	167.8	167.8	158.5	158.5	158.5	148.6	148.6	150.1	
			SHC	108.3	136.2	164.2	105.2	133.1	161.0	101.9	129.7	157.6	98.3	126.2	154.0	94.6	122.3	150.1	
	72	TC	203.1	203.1	203.1	194.4	194.4	194.4	185.2	185.2	185.2	175.2	175.2	175.2	164.5	164.5	164.5		
		SHC	79.8	107.9	136.0	76.7	104.8	132.9	73.4	101.4	129.5	69.9	97.9	125.9	66.2	94.2	122.1		
	76	TC	—	218.7	218.7	—	209.4	209.4	—	199.5	199.5	—	188.8	188.8	—	177.4	177.4		
		SHC	—	84.9	113.6	—	81.8	110.4	—	78.6	107.1	—	75.1	103.5	—	71.3	99.6		
	6000 cfm	EA (wb)	58	TC	172.8	172.8	195.2	166.6	166.6	188.1	159.9	159.9	180.5	151.6	151.6	171.2	144.6	144.6	163.3
				SHC	150.5	172.8	195.2	145.0	166.6	188.1	139.2	159.9	180.5	132.0	151.6	171.2	125.9	144.6	163.3
62			TC	175.6	175.6	194.2	168.6	168.6	189.0	161.0	161.0	183.4	152.8	152.8	177.2	144.2	144.2	169.0	
			SHC	138.7	166.5	194.2	134.5	161.8	189.0	130.0	156.7	183.4	125.2	151.2	177.2	119.4	144.2	169.0	
67			TC	188.2	188.2	188.2	179.9	179.9	179.9	171.0	171.0	171.2	161.4	161.4	167.3	151.8	151.8	159.8	
			SHC	114.7	146.3	177.9	111.6	143.1	174.7	108.2	139.7	171.2	104.5	135.9	167.3	99.2	129.5	159.8	
72		TC	207.2	207.2	207.2	198.2	198.2	198.2	188.6	188.6	188.6	178.2	178.2	178.2	167.2	167.2	167.2		
		SHC	82.0	113.8	145.6	78.8	110.6	142.4	75.5	107.3	139.0	72.0	103.7	135.4	68.3	99.9	131.6		
76		TC	—	222.7	222.7	—	213.1	213.1	—	202.8	202.8	—	191.7	191.7	—	179.9	179.9		
		SHC	—	87.5	120.0	—	84.4	116.8	—	81.0	113.3	—	77.4	109.4	—	73.5	105.4		
6750 cfm		EA (wb)	58	TC	179.0	179.0	202.1	172.4	172.4	194.7	165.3	165.3	186.6	157.6	157.6	177.9	149.2	149.2	168.5
				SHC	155.8	179.0	202.1	150.1	172.4	194.7	143.9	165.3	186.6	137.2	157.6	177.9	129.9	149.2	168.5
	62		TC	180.3	180.3	205.4	173.1	173.1	200.0	165.4	165.4	193.9	157.8	157.8	185.0	149.3	149.3	175.0	
			SHC	145.7	175.6	205.4	141.5	170.7	200.0	136.9	165.4	193.9	130.6	157.8	185.0	123.6	149.3	175.0	
	67		TC	191.3	191.3	191.3	182.7	182.7	187.8	173.4	173.4	182.4	164.7	164.7	175.4	155.0	155.0	168.2	
			SHC	120.9	156.1	191.3	117.6	152.7	187.8	112.6	147.5	182.4	108.4	141.9	175.4	103.2	135.7	168.2	
	72	TC	210.4	210.4	210.4	201.2	201.2	201.2	191.3	191.3	191.3	180.6	180.6	180.6	169.3	169.3	169.3		
		SHC	83.9	119.4	154.9	80.7	116.2	151.7	77.4	112.8	148.2	73.9	109.3	144.6	70.2	105.5	140.8		
	76	TC	—	225.8	225.8	—	216.3	216.3	—	205.7	205.7	—	194.1	194.1	—	182.0	182.0		
		SHC	—	89.7	125.8	—	86.4	122.2	—	83.0	118.6	—	79.3	114.8	—	75.4	110.6		

LEGEND

- db — dry bulb
- EA — Entering Air Temperature (°F)
- SHC — Sensible Heat Capacity (1000 Btuh) gross
- TC — Total Capacity (1000 Btuh) gross
- wb — wet bulb

38AXD16/40RLA16 Stage 1 Combination Ratings — 60 Hz

38AXD16/40RLA16				AMBIENT TEMPERATURE (°F)															
				85			95			105			115			125			
				EA (db)			EA (db)			EA (db)			EA (db)			EA (db)			
				75	80	85	75	80	85	75	80	85	75	80	85	75	80	85	
3750 cfm	EA (wb)	58	TC	72.0	72.0	80.6	69.3	69.3	77.6	66.3	66.3	74.2	62.8	62.8	70.4	59.1	59.1	66.2	
			SHC	63.3	72.0	80.6	60.9	69.3	77.6	58.3	66.3	74.2	55.3	62.8	70.4	51.9	59.1	66.2	
		62	TC	72.3	72.3	77.1	69.5	69.5	69.5	66.2	66.2	76.9	62.9	62.9	73.0	59.1	59.1	68.6	
			SHC	57.0	67.1	77.1	52.0	60.6	69.1	55.6	66.2	76.9	52.8	62.9	73.0	49.6	59.1	68.6	
		67	TC	75.1	75.1	79.1	71.7	71.7	77.8	67.9	67.9	76.1	63.9	63.9	74.1	59.6	59.6	71.3	
			SHC	50.7	64.9	79.1	49.4	63.6	77.8	47.9	62.0	76.1	46.2	60.1	74.1	44.1	57.7	71.3	
	72	TC	81.2	81.2	81.2	77.6	77.6	77.6	73.6	73.6	73.6	69.3	69.3	69.3	64.5	64.5	64.5		
		SHC	34.4	48.1	61.8	33.2	46.9	60.7	31.8	45.6	59.5	30.4	44.2	58.1	28.8	42.7	56.6		
	76	TC	—	86.3	86.3	—	82.5	82.5	—	78.3	78.3	—	73.8	73.8	—	68.8	68.8		
		SHC	—	34.9	47.8	—	33.8	46.8	—	32.5	45.7	—	31.2	44.5	—	29.6	43.0		
	4500 cfm	EA (wb)	58	TC	74.0	74.0	83.0	71.1	71.1	79.8	67.9	67.9	76.2	64.4	64.4	72.2	60.4	60.4	67.8
				SHC	65.0	74.0	83.0	62.4	71.1	79.8	59.6	67.9	76.2	56.6	64.4	72.2	53.1	60.4	67.8
62			TC	74.0	74.0	86.0	71.2	71.2	82.8	68.0	68.0	79.0	64.4	64.4	74.8	60.5	60.5	70.3	
			SHC	62.0	74.0	86.0	59.7	71.2	82.8	57.0	68.0	79.0	53.9	64.4	74.8	50.7	60.5	70.3	
67			TC	75.7	75.7	86.1	72.3	72.3	84.2	68.6	68.6	81.8	64.8	64.8	78.4	60.5	60.5	75.1	
			SHC	53.7	69.9	86.1	52.2	68.2	84.2	50.4	66.1	81.8	48.1	63.3	78.4	45.8	60.5	75.1	
72		TC	82.0	82.0	82.0	78.4	78.4	78.4	74.3	74.3	74.3	69.9	69.9	69.9	65.0	65.0	65.0		
		SHC	34.9	50.9	66.9	33.7	49.7	65.8	32.4	48.5	64.6	31.0	47.1	63.2	29.6	45.7	61.8		
76		TC	—	87.3	87.3	—	83.4	83.4	—	79.1	79.1	—	74.5	74.5	—	69.4	69.4		
		SHC	—	35.5	50.7	—	34.3	49.7	—	33.0	48.5	—	31.7	47.2	—	30.1	45.7		
5250 cfm		EA (wb)	58	TC	75.6	75.6	84.9	72.6	72.6	81.5	69.3	69.3	77.8	65.6	65.6	73.7	61.6	61.6	69.1
				SHC	66.3	75.6	84.9	63.7	72.6	81.5	60.8	69.3	77.8	57.6	65.6	73.7	54.0	61.6	69.1
	62		TC	75.6	75.6	88.0	72.7	72.7	84.6	69.3	69.3	80.7	65.6	65.6	76.4	61.6	61.6	71.6	
			SHC	63.3	75.6	88.0	60.8	72.7	84.6	58.0	69.3	80.7	54.9	65.6	76.4	51.5	61.6	71.6	
	67		TC	76.3	76.3	91.1	73.1	73.1	88.5	69.8	69.8	80.1	65.6	65.6	81.8	61.6	61.6	76.6	
			SHC	55.9	73.5	91.1	54.1	71.3	88.5	49.6	64.8	80.1	49.5	65.6	81.8	46.6	61.6	76.6	
	72	TC	82.6	82.6	82.6	78.9	78.9	78.9	74.8	74.8	74.8	70.2	70.2	70.2	65.3	65.3	66.8		
		SHC	35.3	53.5	71.7	34.2	52.4	70.6	32.9	51.2	69.4	31.6	49.9	68.1	30.3	48.5	66.8		
	76	TC	—	88.0	88.0	—	84.0	84.0	—	79.7	79.7	—	74.9	74.9	—	69.8	69.8		
		SHC	—	35.6	53.0	—	34.4	52.0	—	33.2	50.8	—	31.8	49.4	—	30.3	47.9		
	6000 cfm	EA (wb)	58	TC	76.9	76.9	86.4	73.8	73.8	82.9	70.4	70.4	79.1	66.6	66.6	74.9	62.5	62.5	70.2
				SHC	67.4	76.9	86.4	64.7	73.8	82.9	61.7	70.4	79.1	58.4	66.6	74.9	54.8	62.5	70.2
62			TC	76.9	76.9	89.6	73.9	73.9	86.1	70.4	70.4	82.0	66.7	66.7	77.6	62.5	62.5	72.8	
			SHC	64.3	76.9	89.6	61.8	73.9	86.1	58.9	70.4	82.0	55.7	66.7	77.6	52.2	62.5	72.8	
67			TC	77.3	77.3	92.3	73.8	73.8	92.0	70.4	70.4	87.7	66.6	66.6	83.0	62.5	62.5	77.8	
			SHC	56.4	74.4	92.3	55.7	73.8	92.0	53.1	70.4	87.7	50.3	66.6	83.0	47.1	62.5	77.8	
72		TC	83.1	83.1	83.1	79.3	79.3	79.3	75.1	75.1	75.1	70.5	70.5	73.0	65.5	65.5	71.7		
		SHC	35.6	55.9	76.3	34.6	54.9	75.2	33.4	53.8	74.1	32.3	52.6	73.0	31.1	51.4	71.7		
76		TC	—	88.5	88.5	—	84.5	84.5	—	80.1	80.1	—	75.3	75.3	—	70.1	70.1		
		SHC	—	35.3	54.8	—	34.1	53.7	—	32.9	52.5	—	31.5	51.1	—	30.0	49.6		
6750 cfm		EA (wb)	58	TC	78.0	78.0	87.6	74.8	74.8	84.1	71.3	71.3	80.2	67.5	67.5	75.9	63.2	63.2	71.1
				SHC	68.3	78.0	87.6	65.5	74.8	84.1	62.5	71.3	80.2	59.1	67.5	75.9	55.4	63.2	71.1
	62		TC	78.0	78.0	90.9	74.8	74.8	87.2	71.3	71.3	83.1	67.5	67.5	78.6	63.2	63.2	73.6	
			SHC	65.1	78.0	90.9	62.5	74.8	87.2	59.6	71.3	83.1	56.3	67.5	78.6	52.7	63.2	73.6	
	67		TC	78.0	78.0	97.2	74.9	74.9	93.3	71.4	71.4	89.0	67.5	67.5	84.1	63.2	63.2	78.8	
			SHC	58.8	78.0	97.2	56.4	74.9	93.3	53.8	71.4	89.0	50.8	67.5	84.1	47.6	63.2	78.8	
	72	TC	83.4	83.4	83.4	79.6	79.6	79.7	75.3	75.3	78.7	70.7	70.7	77.7	65.6	65.6	76.7		
		SHC	35.9	58.3	80.6	35.0	57.3	79.7	34.0	56.4	78.7	33.0	55.4	77.7	32.1	54.4	76.7		
	76	TC	—	88.9	88.9	—	84.8	84.8	—	80.4	80.4	—	75.6	75.6	—	70.3	70.3		
		SHC	—	34.4	56.0	—	33.3	54.9	—	32.0	53.7	—	30.7	52.3	—	29.2	50.7		

LEGEND

- db — dry bulb
- EA — Entering Air Temperature (°F)
- SHC — Sensible Heat Capacity (1000 Btuh) gross
- TC — Total Capacity (1000 Btuh) gross
- wb — wet bulb

38AXZ25/40RLA25 Stage 2 Combination Ratings — 60 Hz

38AXZ25/40RLA25				AMBIENT TEMPERATURE (°F)															
				85			95			105			115			125			
				EA (db)			EA (db)			EA (db)			EA (db)			EA (db)			
				75	80	85	75	80	85	75	80	85	75	80	85	75	80	85	
6000 cfm	EA (wb)	58	TC	225.2	225.2	253.2	218.1	218.1	245.2	210.4	210.4	236.6	202.1	202.1	227.2	193.0	193.0	217.0	
			SHC	197.2	225.2	253.2	191.0	218.1	245.2	184.3	210.4	236.6	177.0	202.1	227.2	169.0	193.0	217.0	
		62	TC	237.3	237.3	237.7	228.2	228.2	233.3	218.4	218.4	228.3	208.0	208.0	223.1	196.8	196.8	217.2	
			SHC	177.1	207.4	237.7	172.7	203.0	233.3	168.0	198.1	228.3	162.9	193.0	223.1	157.5	187.4	217.2	
		67	TC	259.1	259.1	259.1	248.8	248.8	248.8	238.0	238.0	238.0	226.5	226.5	226.5	214.2	214.2	214.2	
			SHC	143.6	174.0	204.4	141.1	171.5	201.9	136.5	166.8	197.2	131.6	161.9	192.3	126.5	156.8	187.1	
	72	TC	282.4	282.4	282.4	271.5	271.5	271.5	259.9	259.9	259.9	247.4	247.4	247.4	234.0	234.0	234.0		
		SHC	113.1	143.9	174.6	108.8	139.5	170.2	104.3	134.9	165.5	99.5	130.0	160.6	94.4	124.9	155.4		
	76	TC	—	302.6	302.6	—	290.9	290.9	—	278.4	278.4	—	264.9	264.9	—	250.6	250.6		
		SHC	—	118.0	150.8	—	113.7	146.1	—	109.1	141.2	—	104.3	136.1	—	99.2	130.7		
	7000 cfm	EA (wb)	58	TC	236.2	236.2	265.7	228.5	228.5	257.0	220.2	220.2	247.7	211.2	211.2	237.6	201.5	201.5	226.6
				SHC	206.7	236.2	265.7	200.0	228.5	257.0	192.7	220.2	247.7	184.9	211.2	237.6	176.3	201.5	226.6
62			TC	244.0	244.0	258.4	234.5	234.5	253.5	224.3	224.3	248.1	213.6	213.6	242.0	203.1	203.1	230.1	
			SHC	189.2	223.8	258.4	184.6	219.0	253.5	179.6	213.8	248.1	174.1	208.0	242.0	165.5	197.8	230.1	
67			TC	265.7	265.7	265.7	255.1	255.1	255.1	243.8	243.8	243.8	231.7	231.7	231.7	218.9	218.9	218.9	
			SHC	152.9	187.8	222.8	148.5	183.4	218.3	143.8	178.7	213.5	138.9	173.7	208.5	133.7	168.5	203.3	
72		TC	289.9	289.9	289.9	278.4	278.4	278.4	266.2	266.2	266.2	253.0	253.0	253.0	239.0	239.0	239.0		
		SHC	115.7	150.9	186.1	111.4	146.5	181.6	106.7	141.8	176.8	101.9	136.8	171.8	96.7	131.6	166.4		
76		TC	—	310.4	310.4	—	298.0	298.0	—	284.8	284.8	—	270.7	270.7	—	255.8	255.8		
		SHC	—	121.1	157.8	—	116.7	153.1	—	112.0	148.2	—	107.1	143.0	—	101.9	137.6		
8000 cfm		EA (wb)	58	TC	245.3	245.3	275.9	237.1	237.1	266.7	228.2	228.2	256.8	218.7	218.7	246.1	208.4	208.4	234.5
				SHC	214.6	245.3	275.9	207.4	237.1	266.7	199.7	228.2	256.8	191.4	218.7	246.1	182.3	208.4	234.5
	62		TC	249.6	249.6	277.3	239.8	239.8	271.6	230.0	230.0	262.1	218.9	218.9	255.5	208.6	208.6	243.4	
			SHC	200.3	238.8	277.3	195.2	233.4	271.6	188.2	225.2	262.1	182.4	218.9	255.5	173.7	208.6	243.4	
	67		TC	271.1	271.1	271.1	260.1	260.1	260.1	248.4	248.4	248.4	235.8	235.8	235.8	222.5	222.5	222.5	
			SHC	160.0	199.3	238.6	155.5	194.8	234.0	150.9	190.1	229.3	145.9	185.1	224.3	140.7	179.8	218.9	
	72	TC	295.8	295.8	295.8	283.8	283.8	283.8	271.0	271.0	271.0	257.4	257.4	257.4	242.9	242.9	242.9		
		SHC	117.9	157.4	196.9	113.5	152.9	192.3	108.8	148.1	187.4	103.9	143.1	182.3	98.7	137.8	176.9		
	76	TC	—	316.4	316.4	—	303.5	303.5	—	289.8	289.8	—	275.2	275.2	—	259.7	259.7		
		SHC	—	123.7	164.4	—	119.2	159.7	—	114.5	154.8	—	109.5	149.5	—	104.2	144.0		
	9000 cfm	EA (wb)	58	TC	253.0	253.0	284.7	244.4	244.4	275.0	235.1	235.1	264.5	225.0	225.0	253.2	214.2	214.2	241.1
				SHC	221.3	253.0	284.7	213.7	244.4	275.0	205.6	235.1	264.5	196.8	225.0	253.2	187.4	214.2	241.1
62			TC	256.2	256.2	284.3	244.9	244.9	285.8	235.2	235.2	274.6	227.8	227.8	248.4	214.4	214.4	250.2	
			SHC	205.3	244.8	284.3	203.9	244.9	285.8	195.9	235.2	274.6	180.1	214.2	248.4	178.5	214.4	250.2	
67			TC	275.5	275.5	275.5	264.1	264.1	264.1	252.0	252.0	252.0	239.1	239.1	239.3	225.3	225.3	233.8	
			SHC	166.9	210.4	253.9	162.4	205.9	249.4	157.7	201.1	244.6	152.7	196.0	239.3	147.4	190.6	233.8	
72		TC	300.4	300.4	300.4	288.0	288.0	288.0	274.9	274.9	274.9	260.8	260.8	260.8	246.0	246.0	246.0		
		SHC	119.8	163.5	207.1	115.4	158.9	202.5	110.6	154.1	197.6	105.7	149.0	192.4	100.5	143.7	187.0		
76		TC	—	321.1	321.1	—	307.8	307.8	—	293.7	293.7	—	278.7	278.7	—	262.8	262.8		
		SHC	—	125.8	170.6	—	121.3	165.8	—	116.5	160.8	—	111.4	155.5	—	106.1	149.8		
10,000 cfm		EA (wb)	58	TC	259.7	259.7	292.2	250.6	250.6	282.1	240.9	240.9	271.1	230.4	230.4	259.4	219.3	219.3	246.8
				SHC	227.1	259.7	292.2	219.2	250.6	282.1	210.7	240.9	271.1	201.5	230.4	259.4	191.7	219.3	246.8
	62		TC	259.8	259.8	303.4	250.8	250.8	292.8	241.1	241.1	281.5	230.6	230.6	269.3	219.4	219.4	256.2	
			SHC	216.3	259.8	303.4	208.8	250.8	292.8	200.7	241.1	281.5	192.0	230.6	269.3	182.6	219.4	256.2	
	67		TC	279.0	279.0	279.0	267.3	267.3	267.3	254.9	254.9	259.2	241.7	241.7	253.7	227.7	227.7	247.9	
			SHC	173.5	221.2	268.9	169.0	216.6	264.2	164.3	211.7	259.2	159.2	206.5	253.7	153.9	200.9	247.9	
	72	TC	304.2	304.2	304.2	291.5	291.5	291.5	278.0	278.0	278.0	263.6	263.6	263.6	248.4	248.4	248.4		
		SHC	121.4	169.2	216.9	116.9	164.6	212.2	112.2	159.8	207.3	107.3	154.7	202.0	102.1	149.3	196.6		
	76	TC	—	325.0	325.0	—	311.3	311.3	—	296.9	296.9	—	281.5	281.5	—	265.2	265.2		
		SHC	—	127.6	176.3	—	123.0	171.4	—	118.1	166.3	—	113.0	160.9	—	107.6	155.2		

LEGEND

- db — dry bulb
- EA — Entering Air Temperature (°F)
- SHC — Sensible Heat Capacity (1000 Btuh) gross
- TC — Total Capacity (1000 Btuh) gross
- wb — wet bulb

38AXZ25/40RLA25 Stage 1 Combination Ratings — 60 Hz

38AXZ25/40RLA25				AMBIENT TEMPERATURE (°F)															
				85			95			105			115			125			
				EA (db)			EA (db)			EA (db)			EA (db)			EA (db)			
				75	80	85	75	80	85	75	80	85	75	80	85	75	80	85	
5000 cfm	EA (wb)	58	TC	130.4	130.4	147.8	125.9	125.9	142.7	121.0	121.0	137.1	115.7	115.7	131.2	110.0	110.0	124.7	
			SHC	113.0	130.4	147.8	109.0	125.9	142.7	104.8	121.0	137.1	100.2	115.7	131.2	95.3	110.0	124.7	
		62	TC	130.6	130.6	153.8	126.0	126.0	148.5	121.1	121.1	142.7	115.8	115.8	136.5	110.1	110.1	129.7	
			SHC	107.3	130.6	153.8	103.5	126.0	148.5	99.5	121.1	142.7	95.2	115.8	136.5	90.5	110.1	129.7	
		67	TC	141.5	141.5	141.5	135.4	135.4	136.3	128.8	128.8	133.7	121.8	121.8	131.0	114.4	114.4	128.0	
			SHC	86.9	112.8	138.7	84.6	110.4	136.3	82.2	108.0	133.7	79.6	105.3	131.0	76.8	102.4	128.0	
	72	TC	157.8	157.8	157.8	151.0	151.0	151.0	143.8	143.8	143.8	136.1	136.1	136.1	127.9	127.9	127.9		
		SHC	62.1	88.1	114.1	59.8	85.8	111.7	57.4	83.3	109.3	54.8	80.8	106.7	52.1	78.1	104.0		
	76	TC	—	171.9	171.9	—	164.6	164.6	—	156.9	156.9	—	148.7	148.7	—	139.8	139.8		
		SHC	—	68.1	94.2	—	65.8	91.9	—	63.3	89.5	—	60.8	86.9	—	58.0	84.1		
	6000 cfm	EA (wb)	58	TC	138.3	138.3	156.6	133.3	133.3	151.0	128.0	128.0	144.9	122.2	122.2	138.4	116.0	116.0	131.4
				SHC	120.0	138.3	156.6	115.6	133.3	151.0	111.0	128.0	144.9	106.0	122.2	138.4	100.6	116.0	131.4
62			TC	138.4	138.4	162.9	133.4	133.4	157.0	128.1	128.1	150.8	122.4	122.4	144.0	116.1	116.1	136.6	
			SHC	113.9	138.4	162.9	109.8	133.4	157.0	105.5	128.1	150.8	100.7	122.4	144.0	95.6	116.1	136.6	
67			TC	145.4	145.4	156.0	139.0	139.0	153.4	132.2	132.2	150.6	125.0	125.0	147.5	117.4	117.4	143.7	
			SHC	95.1	125.6	156.0	92.7	123.1	153.4	90.2	120.4	150.6	87.4	117.4	147.5	84.3	114.0	143.7	
72		TC	161.8	161.8	161.8	154.6	154.6	154.6	147.1	147.1	147.1	139.1	139.1	139.1	130.5	130.5	130.5		
		SHC	65.3	96.1	126.8	63.0	93.7	124.4	60.5	91.2	121.9	57.9	88.6	119.3	55.2	85.9	116.6		
76		TC	—	176.1	176.1	—	168.5	168.5	—	160.4	160.4	—	151.8	151.8	—	142.6	142.6		
		SHC	—	71.9	102.8	—	69.5	100.5	—	67.1	98.0	—	64.5	95.3	—	61.7	92.6		
7000 cfm		EA (wb)	58	TC	144.6	144.6	163.6	139.2	139.2	157.6	133.5	133.5	151.1	127.4	127.4	144.2	120.8	120.8	136.7
				SHC	125.5	144.6	163.6	120.9	139.2	157.6	115.9	133.5	151.1	110.6	127.4	144.2	104.9	120.8	136.7
	62		TC	144.7	144.7	170.1	139.4	139.4	163.9	133.7	133.7	157.2	127.5	127.5	149.9	120.9	120.9	142.1	
			SHC	119.3	144.7	170.1	114.9	139.4	163.9	110.2	133.7	157.2	105.1	127.5	149.9	99.6	120.9	142.1	
	67		TC	148.4	148.4	172.0	141.9	141.9	169.0	135.0	135.0	165.4	128.7	128.7	155.2	121.0	121.0	152.8	
			SHC	102.7	137.3	172.0	100.1	134.5	169.0	97.3	131.3	165.4	91.7	123.5	155.2	89.2	121.0	152.8	
	72	TC	164.6	164.6	164.6	157.2	157.2	157.2	149.5	149.5	149.5	141.2	141.2	141.2	132.3	132.3	132.3		
		SHC	68.2	103.6	138.9	65.8	101.2	136.6	63.4	98.7	134.0	60.8	96.1	131.4	58.1	93.4	128.7		
	76	TC	—	179.1	179.1	—	171.3	171.3	—	163.0	163.0	—	154.1	154.1	—	144.6	144.6		
		SHC	—	75.2	110.8	—	72.9	108.5	—	70.4	105.9	—	67.7	103.3	—	64.9	100.5		
	8000 cfm	EA (wb)	58	TC	149.7	149.7	169.3	144.0	144.0	162.9	138.0	138.0	156.1	131.6	131.6	148.8	124.6	124.6	140.9
				SHC	130.0	149.7	169.3	125.2	144.0	162.9	119.9	138.0	156.1	114.3	131.6	148.8	108.3	124.6	140.9
62			TC	149.8	149.8	176.0	144.1	144.1	169.4	138.1	138.1	162.3	131.7	131.7	154.7	124.7	124.7	146.5	
			SHC	123.6	149.8	176.0	118.9	144.1	169.4	114.0	138.1	162.3	108.6	131.7	154.7	102.9	124.7	146.5	
67			TC	151.1	151.1	185.8	144.6	144.6	181.8	138.3	138.3	174.5	131.8	131.8	166.3	124.8	124.8	157.5	
			SHC	109.4	147.6	185.8	106.4	144.1	181.8	102.1	138.3	174.5	97.3	131.8	166.3	92.1	124.8	157.5	
72		TC	166.7	166.7	166.7	159.2	159.2	159.2	151.2	151.2	151.2	142.7	142.7	143.2	133.7	133.7	140.4		
		SHC	70.8	110.8	150.7	68.5	108.4	148.3	66.1	105.9	145.8	63.5	103.3	143.2	60.9	100.6	140.4		
76		TC	—	181.4	181.4	—	173.4	173.4	—	164.9	164.9	—	155.9	155.9	—	146.2	146.2		
		SHC	—	78.2	118.4	—	75.8	116.0	—	73.3	113.5	—	70.7	110.8	—	67.9	108.0		
9000 cfm		EA (wb)	58	TC	153.9	153.9	174.0	148.0	148.0	167.3	141.7	141.7	160.2	135.0	135.0	152.6	127.7	127.7	144.4
				SHC	133.8	153.9	174.0	128.7	148.0	167.3	123.2	141.7	160.2	117.4	135.0	152.6	111.1	127.7	144.4
	62		TC	154.0	154.0	180.9	148.1	148.1	173.9	141.8	141.8	166.6	135.1	135.1	158.6	127.8	127.8	150.1	
			SHC	127.2	154.0	180.9	122.3	148.1	173.9	117.1	141.8	166.6	111.6	135.1	158.6	105.6	127.8	150.1	
	67		TC	154.7	154.7	190.5	148.3	148.3	187.0	142.0	142.0	179.0	135.2	135.2	170.5	127.9	127.9	161.3	
			SHC	112.3	151.4	190.5	109.6	148.3	187.0	104.9	142.0	179.0	99.9	135.2	170.5	94.6	127.9	161.3	
	72	TC	168.4	168.4	168.4	160.7	160.7	160.7	152.6	152.6	157.3	144.0	144.0	154.6	134.8	134.8	151.7		
		SHC	73.4	117.8	162.1	71.1	115.4	159.8	68.7	113.0	157.3	66.2	110.4	154.6	63.6	107.6	151.7		
	76	TC	—	183.3	183.3	—	175.1	175.1	—	166.4	166.4	—	157.2	157.2	—	147.4	147.4		
		SHC	—	80.9	125.5	—	78.5	123.1	—	76.0	120.6	—	73.4	117.9	—	70.6	115.1		

LEGEND

- db — dry bulb
- EA — Entering Air Temperature (°F)
- SHC — Sensible Heat Capacity (1000 Btuh) gross
- TC — Total Capacity (1000 Btuh) gross
- wb — wet bulb

38AXD25/40RLA25 Stage 3 Combination Ratings — 60 Hz

38AXD25/40RLA25			AMBIENT TEMPERATURE (°F)																
			85			95			105			115			125				
			EA (db)			EA (db)			EA (db)			EA (db)			EA (db)				
			75	80	85	75	80	85	75	80	85	75	80	85	75	80	85		
6000 cfm	EA (wb)	58	TC	214.2	214.2	243.4	205.8	205.8	233.5	195.4	195.4	222.7	184.4	184.4	210.7	172.8	172.8	197.9	
			SHC	183.9	213.7	243.4	177.0	205.2	233.5	168.0	195.4	222.7	158.2	184.4	210.7	147.8	172.8	197.9	
		62	TC	230.1	230.1	230.1	217.9	217.9	219.3	205.3	205.3	212.1	191.6	191.6	204.6	177.2	177.2	196.3	
			SHC	164.7	195.5	226.2	157.8	188.5	219.3	150.6	181.3	212.1	143.1	173.8	204.6	135.1	165.7	196.3	
		67	TC	254.0	254.0	254.0	240.0	240.0	240.0	227.4	227.4	227.4	213.1	213.1	213.1	197.3	197.3	197.3	
			SHC	138.8	168.1	197.3	126.0	155.9	185.9	119.7	150.2	180.6	112.4	142.9	173.4	104.6	135.2	165.8	
	72	TC	278.0	278.0	278.0	265.4	265.4	265.4	250.9	250.9	250.9	235.6	235.6	235.6	218.6	218.6	218.6		
		SHC	103.8	131.6	159.5	96.2	125.0	153.7	88.9	118.2	147.4	81.5	111.2	141.0	73.5	103.5	133.4		
	76	TC	—	301.2	301.2	—	286.7	286.7	—	272.3	272.3	—	255.6	255.6	—	237.0	237.0		
		SHC	—	109.7	140.1	—	98.9	131.9	—	92.6	125.6	—	85.8	115.9	—	78.1	105.3		
	7000 cfm	EA (wb)	58	TC	228.0	228.0	258.8	217.8	217.8	247.6	206.9	206.9	235.6	195.2	195.2	222.7	182.5	182.5	208.7
				SHC	197.2	228.0	258.8	188.0	217.8	247.6	178.2	206.9	235.6	167.6	195.2	222.7	156.3	182.5	208.7
62			TC	237.8	237.8	249.5	225.5	225.5	242.2	212.2	212.2	234.5	198.0	198.0	225.8	184.1	184.1	214.4	
			SHC	178.6	214.1	249.5	171.6	206.9	242.2	164.0	199.3	234.5	155.9	190.8	225.8	146.3	180.3	214.4	
67			TC	260.5	260.5	260.5	248.5	248.5	248.5	234.0	234.0	234.0	218.6	218.6	218.6	202.1	202.1	202.1	
			SHC	141.2	175.6	210.1	135.3	170.4	205.4	128.1	163.3	198.6	120.5	155.8	191.1	112.6	148.0	183.4	
72		TC	284.8	284.8	284.8	271.7	271.7	271.7	258.3	258.3	258.3	241.7	241.7	241.7	224.0	224.0	224.0		
		SHC	112.9	146.5	180.1	106.0	140.7	175.4	92.1	126.4	160.8	84.3	118.9	153.5	76.3	111.0	145.8		
76		TC	—	309.1	309.1	—	294.8	294.8	—	278.8	278.8	—	261.9	261.9	—	242.6	242.6		
		SHC	—	109.5	142.3	—	103.3	137.7	—	96.6	127.1	—	89.5	121.5	—	81.5	114.5		
8,000 cfm		EA (wb)	58	TC	238.6	238.6	270.7	227.9	227.9	258.9	216.4	216.4	246.3	204.3	204.3	233.0	191.0	191.0	218.2
				SHC	206.5	238.6	270.7	196.9	227.9	258.9	186.5	216.4	246.3	175.7	204.3	233.0	163.7	191.0	218.2
	62		TC	253.0	253.0	253.0	231.8	231.8	261.6	218.7	218.7	252.2	204.7	204.7	240.2	191.6	191.6	225.3	
			SHC	180.4	216.2	252.1	183.3	222.5	261.6	174.9	213.6	252.2	165.1	202.7	240.2	153.8	189.6	225.3	
	67		TC	267.5	267.5	267.5	253.9	253.9	253.9	239.0	239.0	239.0	223.0	223.0	223.0	206.0	206.0	206.0	
			SHC	150.1	189.6	229.2	143.4	183.2	223.1	136.1	176.0	216.0	128.5	168.5	208.5	120.5	160.4	200.4	
	72	TC	294.3	294.3	294.3	280.2	280.2	280.2	263.6	263.6	263.6	247.0	247.0	247.0	228.8	228.8	228.8		
		SHC	109.0	147.3	185.5	102.2	141.1	180.1	94.6	133.7	172.7	87.0	126.2	165.5	78.9	118.3	157.7		
	76	TC	—	316.4	316.4	—	301.2	301.2	—	284.3	284.3	—	266.1	266.1	—	247.4	247.4		
		SHC	—	113.4	146.9	—	106.9	142.5	—	99.8	136.5	—	92.2	129.6	—	84.5	122.4		
	9,000 cfm	EA (wb)	58	TC	247.8	247.8	281.0	236.8	236.8	268.9	224.4	224.4	255.3	211.5	211.5	240.9	197.5	197.5	225.5
				SHC	214.7	247.8	281.0	204.7	236.8	268.9	193.6	224.4	255.3	182.0	211.5	240.9	169.5	197.5	225.5
62			TC	250.3	250.3	286.0	237.6	237.6	277.3	225.8	225.8	264.1	212.7	212.7	247.9	197.7	197.7	235.0	
			SHC	200.9	243.4	286.0	193.1	235.2	277.3	182.9	223.5	264.1	171.0	209.4	247.9	160.5	197.7	235.0	
67			TC	273.0	273.0	273.0	258.8	258.8	258.8	243.0	243.0	243.0	226.5	226.5	226.5	209.2	209.2	217.6	
			SHC	158.3	202.7	247.1	151.3	195.8	240.3	143.9	188.5	233.0	136.3	180.8	225.4	128.5	173.0	217.6	
72		TC	299.5	299.5	299.5	285.3	285.3	285.3	267.7	267.7	267.7	250.1	250.1	250.1	232.1	232.1	232.1		
		SHC	111.4	154.7	198.0	104.6	148.1	191.6	96.8	140.5	184.1	89.0	132.8	176.6	81.1	125.0	168.9		
76		TC	—	322.1	322.1	—	306.0	306.0	—	288.5	288.5	—	270.5	270.5	—	250.1	250.1		
		SHC	—	116.5	156.6	—	109.7	150.8	—	102.4	144.0	—	94.8	136.9	—	86.6	129.1		
10,000 cfm		EA (wb)	58	TC	255.5	255.5	289.6	243.8	243.8	276.8	231.7	231.7	263.4	217.8	217.8	248.0	203.8	203.8	232.5
				SHC	221.4	255.5	289.6	210.9	243.8	276.8	200.0	231.7	263.4	187.6	217.8	248.0	175.0	203.8	232.5
	62		TC	257.3	257.3	295.8	245.1	245.1	285.1	231.6	231.6	273.4	218.0	218.0	258.3	203.5	203.5	241.7	
			SHC	207.7	251.7	295.8	198.9	242.0	285.1	189.3	231.4	273.4	177.8	218.0	258.3	165.3	203.5	241.7	
	67		TC	276.4	276.4	276.4	261.7	261.7	261.7	246.0	246.0	249.5	229.4	229.4	241.8	211.8	211.8	233.7	
			SHC	165.8	214.7	263.7	158.8	207.8	256.8	151.5	200.5	249.5	143.9	192.9	241.8	136.0	184.9	233.7	
	72	TC	303.6	303.6	303.6	288.6	288.6	288.6	271.1	271.1	271.1	253.1	253.1	253.1	234.1	234.1	234.1		
		SHC	113.4	161.3	209.2	106.5	154.5	202.5	98.8	146.9	195.1	91.0	139.2	187.5	82.9	131.3	179.6		
	76	TC	—	326.4	326.4	—	309.7	309.7	—	291.9	291.9	—	272.9	272.9	—	252.9	252.9		
		SHC	—	119.0	164.3	—	111.8	157.7	—	104.4	150.7	—	96.6	143.3	—	88.6	135.5		

LEGEND

- db — dry bulb
- EA — Entering Air Temperature (°F)
- SHC — Sensible Heat Capacity (1000 Btuh) gross
- TC — Total Capacity (1000 Btuh) gross
- wb — wet bulb

38AXD25/40RLA25 Stage 2 Combination Ratings — 60 Hz

38AXD25/40RLA25			AMBIENT TEMPERATURE (°F)																
			85			95			105			115			125				
			EA (db)			EA (db)			EA (db)			EA (db)			EA (db)				
			75	80	85	75	80	85	75	80	85	75	80	85	75	80	85		
5000 cfm	EA (wb)	58	TC	186.3	186.3	202.6	179.2	179.2	196.9	171.3	171.3	190.6	162.8	162.8	183.9	154.3	154.3	174.2	
			SHC	157.6	180.1	202.6	152.7	174.8	196.9	147.4	169.0	190.6	141.8	162.8	183.9	134.4	154.3	174.2	
		62	TC	195.3	195.3	195.4	186.7	186.7	190.8	178.3	178.3	183.5	169.2	169.2	176.1	159.3	159.3	168.1	
			SHC	144.5	170.0	195.4	140.2	165.5	190.8	134.4	159.0	183.5	128.4	152.3	176.1	121.9	145.0	168.1	
		67	TC	214.7	214.7	214.7	205.5	205.5	205.5	195.4	195.4	195.4	184.3	184.3	184.3	172.2	172.2	172.2	
			SHC	118.9	144.4	170.0	115.0	140.6	166.1	110.8	136.3	161.9	106.2	131.8	157.3	101.4	126.9	152.4	
	72	TC	235.1	235.1	235.1	225.3	225.3	225.3	214.3	214.3	214.3	202.4	202.4	202.4	189.3	189.3	189.3		
		SHC	92.5	117.9	143.3	88.7	114.1	139.5	84.6	109.9	135.3	80.1	105.5	130.8	75.3	100.6	126.0		
	76	TC	—	252.4	252.4	—	241.9	241.9	—	230.3	230.3	—	217.5	217.5	—	203.6	203.6		
		SHC	—	96.2	122.7	—	92.5	119.0	—	88.4	114.9	—	84.0	108.2	—	79.2	103.8		
	6000 cfm	EA (wb)	58	TC	195.9	195.9	221.2	189.0	189.0	213.3	181.2	181.2	204.5	172.6	172.6	194.8	163.1	163.1	184.1
				SHC	170.5	195.9	221.2	164.7	189.0	213.3	157.9	181.2	204.5	150.3	172.6	194.8	142.1	163.1	184.1
62			TC	203.5	203.5	211.8	195.4	195.4	205.3	186.5	186.5	198.2	176.7	176.7	190.4	165.9	165.9	182.1	
			SHC	154.5	183.2	211.8	149.2	177.3	205.3	143.4	170.8	198.2	137.2	163.8	190.4	130.5	156.3	182.1	
67			TC	221.8	221.8	221.8	212.0	212.0	212.0	201.2	201.2	201.2	189.5	189.5	189.5	176.8	176.8	176.8	
			SHC	126.9	157.1	187.3	123.0	153.1	183.3	118.7	148.9	179.1	114.1	144.2	174.3	109.1	139.1	169.1	
72		TC	242.6	242.6	242.6	232.2	232.2	232.2	220.6	220.6	220.6	207.9	207.9	207.9	194.2	194.2	194.2		
		SHC	95.4	125.4	155.3	91.6	121.5	151.4	87.4	117.3	147.2	82.8	112.7	142.6	78.0	107.8	137.7		
76		TC	—	260.0	260.0	—	248.9	248.9	—	236.6	236.6	—	223.2	223.2	—	208.6	208.6		
		SHC	—	99.5	127.5	—	95.8	124.4	—	91.6	120.4	—	87.1	116.1	—	82.3	111.3		
7000 cfm		EA (wb)	58	TC	205.5	205.5	232.0	197.9	197.9	223.4	189.5	189.5	213.9	180.3	180.3	203.5	170.1	170.1	192.0
				SHC	179.1	205.5	232.0	172.5	197.9	223.4	165.1	189.5	213.9	157.1	180.3	203.5	148.2	170.1	192.0
	62		TC	210.8	210.8	225.9	202.2	202.2	219.2	192.7	192.7	211.9	182.4	182.4	203.9	171.2	171.2	195.4	
			SHC	163.1	194.5	225.9	157.7	188.4	219.2	151.8	181.9	211.9	145.4	174.7	203.9	138.6	167.0	195.4	
	67		TC	227.0	227.0	227.0	216.8	216.8	216.8	205.6	205.6	205.6	193.4	193.4	193.4	180.5	180.5	182.5	
			SHC	134.4	169.1	203.7	130.4	165.0	199.6	126.1	160.6	195.2	121.4	155.8	190.2	115.4	148.9	182.5	
	72	TC	248.1	248.1	248.1	237.2	237.2	237.2	225.1	225.1	225.1	212.0	212.0	212.0	197.8	197.8	197.8		
		SHC	97.9	132.2	166.6	94.0	128.4	162.7	89.7	124.1	158.4	85.2	119.4	153.7	80.3	114.5	148.8		
	76	TC	—	265.6	265.6	—	254.1	254.1	—	241.3	241.3	—	227.3	227.3	—	212.2	212.2		
		SHC	—	102.4	135.4	—	98.5	131.6	—	94.3	127.5	—	89.8	123.0	—	84.9	118.2		
	8000 cfm	EA (wb)	58	TC	213.2	213.2	240.7	205.2	205.2	231.6	196.3	196.3	221.6	186.5	186.5	210.5	175.8	175.8	198.4
				SHC	185.8	213.2	240.7	178.8	205.2	231.6	171.0	196.3	221.6	162.5	186.5	210.5	153.2	175.8	198.4
62			TC	216.6	216.6	239.3	207.7	207.7	232.5	197.9	197.9	225.0	187.1	187.1	216.5	176.2	176.2	206.3	
			SHC	171.2	205.3	239.3	165.8	199.1	232.5	159.8	192.4	225.0	153.3	184.9	216.5	146.0	176.2	206.3	
67			TC	230.9	230.9	230.9	220.5	220.5	220.5	209.0	209.0	210.2	196.7	196.7	202.8	184.1	184.1	193.4	
			SHC	141.5	180.5	219.4	137.5	176.3	215.1	133.0	171.6	210.2	127.3	165.0	202.8	120.4	156.9	193.4	
72		TC	252.3	252.3	252.3	241.1	241.1	241.1	228.6	228.6	228.6	215.1	215.1	215.1	200.4	200.4	200.4		
		SHC	100.0	138.7	177.3	96.1	134.7	173.4	91.8	130.4	169.0	87.2	125.8	164.4	82.4	120.9	159.4		
76		TC	—	270.0	270.0	—	258.0	258.0	—	244.8	244.8	—	230.5	230.5	—	214.9	214.9		
		SHC	—	104.7	142.0	—	100.8	138.2	—	96.6	134.0	—	92.0	129.5	—	87.1	124.5		
9000 cfm		EA (wb)	58	TC	219.7	219.7	248.0	211.3	211.3	238.5	202.0	202.0	228.0	191.7	191.7	216.4	180.5	180.5	203.8
				SHC	191.4	219.7	248.0	184.1	211.3	238.5	176.0	202.0	228.0	167.1	191.7	216.4	157.3	180.5	203.8
	62		TC	221.5	221.5	251.8	212.3	212.3	244.6	202.1	202.1	236.9	192.0	192.0	224.9	180.9	180.9	211.9	
			SHC	179.0	215.4	251.8	173.4	209.0	244.6	167.4	202.1	236.9	159.1	192.0	224.9	149.9	180.9	211.9	
	67		TC	234.2	234.2	234.2	223.5	223.5	229.4	212.0	212.0	221.7	200.2	200.2	212.5	187.3	187.3	202.5	
			SHC	148.3	191.2	234.2	144.0	186.7	229.4	138.3	180.0	221.7	131.7	172.1	212.5	124.6	163.5	202.5	
	72	TC	255.6	255.6	255.6	244.1	244.1	244.1	231.3	231.3	231.3	217.5	217.5	217.5	202.5	202.5	202.5		
		SHC	101.8	144.7	187.6	97.9	140.7	183.6	93.6	136.4	179.3	89.1	131.9	174.6	84.3	126.9	169.6		
	76	TC	—	273.4	273.4	—	261.1	261.1	—	247.6	247.6	—	232.9	232.9	—	217.1	217.1		
		SHC	—	106.6	148.1	—	102.7	144.2	—	98.5	140.0	—	93.9	135.3	—	88.9	130.3		

LEGEND

- db — dry bulb
- EA — Entering Air Temperature (°F)
- SHC — Sensible Heat Capacity (1000 Btuh) gross
- TC — Total Capacity (1000 Btuh) gross
- wb — wet bulb

38AXD25/40RLA25 Stage 1 Combination Ratings — 60 Hz

38AXD25/40RLA25				AMBIENT TEMPERATURE (°F)															
				85			95			105			115			125			
				EA (db)			EA (db)			EA (db)			EA (db)			EA (db)			
				75	80	85	75	80	85	75	80	85	75	80	85	75	80	85	
5000 cfm	EA (wb)	58	TC	81.3	81.3	102.3	78.7	78.7	98.8	75.8	75.8	94.9	72.6	72.6	90.7	69.1	69.1	86.0	
			SHC	60.3	81.3	102.3	58.5	78.7	98.8	56.6	75.8	94.9	54.5	72.6	90.7	52.2	69.1	86.0	
		62	TC	82.7	82.7	104.6	79.4	79.4	103.2	77.2	77.2	95.3	72.6	72.6	96.7	69.2	69.2	91.7	
			SHC	52.4	78.5	104.6	51.4	77.3	103.2	49.1	72.2	95.3	48.6	72.6	96.7	46.6	69.2	91.7	
		67	TC	91.2	91.2	91.4	87.4	87.4	90.1	83.0	83.0	88.9	78.3	78.3	87.6	73.3	73.3	86.2	
			SHC	38.7	65.0	91.4	37.5	63.8	90.1	36.2	62.6	88.9	35.0	61.3	87.6	33.8	60.0	86.2	
	72	TC	100.7	100.7	100.7	96.6	96.6	96.6	92.0	92.0	92.0	86.9	86.9	86.9	81.4	81.4	81.4		
		SHC	25.1	51.3	77.5	23.8	50.0	76.2	22.3	48.5	74.7	20.8	47.0	73.2	19.2	45.4	71.6		
	76	TC	—	108.7	108.7	—	104.5	104.5	—	99.6	99.6	—	94.2	94.2	—	88.3	88.3		
		SHC	—	40.1	65.6	—	38.8	64.3	—	37.2	62.8	—	35.6	61.2	—	33.8	59.4		
	6000 cfm	EA (wb)	58	TC	85.4	85.4	107.7	82.5	82.5	103.8	79.3	79.3	99.6	75.7	75.7	94.8	71.8	71.8	89.7
				SHC	63.1	85.4	107.7	61.1	82.5	103.8	59.0	79.3	99.6	56.6	75.7	94.8	54.0	71.8	89.7
62			TC	86.5	86.5	110.2	82.6	82.6	111.0	79.3	79.3	106.4	75.8	75.8	101.2	71.9	71.9	95.7	
			SHC	54.8	82.5	110.2	54.1	82.6	111.0	52.3	79.3	106.4	50.3	75.8	101.2	48.1	71.9	95.7	
67			TC	92.4	92.4	101.8	88.3	88.3	100.6	83.9	83.9	99.4	79.0	79.0	97.9	73.8	73.8	96.6	
			SHC	39.4	70.6	101.8	38.2	69.4	100.6	37.0	68.2	99.4	35.9	66.9	97.9	34.8	65.7	96.6	
72		TC	101.9	101.9	101.9	97.7	97.7	97.7	92.8	92.8	92.8	87.5	87.5	87.5	81.6	81.6	81.6		
		SHC	23.1	54.2	85.2	21.8	52.9	83.9	20.4	51.4	82.5	18.8	49.9	80.9	17.3	48.3	79.4		
76		TC	—	110.0	110.0	—	105.5	105.5	—	100.4	100.4	—	94.8	94.8	—	88.6	88.6		
		SHC	—	40.9	71.2	—	39.5	69.8	—	38.0	68.3	—	36.3	66.6	—	34.5	64.8		
7000 cfm		EA (wb)	58	TC	88.1	88.1	111.4	85.0	85.0	107.3	81.5	81.5	102.7	77.7	77.7	97.6	73.5	73.5	92.1
				SHC	64.8	88.1	111.4	62.7	85.0	107.3	60.3	81.5	102.7	57.7	77.7	97.6	54.9	73.5	92.1
	62		TC	88.2	88.2	119.2	85.1	85.1	114.8	81.6	81.6	109.8	77.7	77.7	104.3	73.5	73.5	98.3	
			SHC	57.1	88.2	119.2	55.3	85.1	114.8	53.3	81.6	109.8	51.1	77.7	104.3	48.7	73.5	98.3	
	67		TC	92.6	92.6	111.5	88.5	88.5	110.3	83.9	83.9	108.9	79.0	79.0	107.5	73.9	73.9	105.9	
			SHC	39.6	75.6	111.5	38.6	74.5	110.3	37.5	73.2	108.9	36.4	72.0	107.5	35.5	70.7	105.9	
	72	TC	102.1	102.1	102.1	97.6	97.6	97.6	92.6	92.6	92.6	87.1	87.1	88.0	81.0	81.0	86.5		
		SHC	20.7	56.5	92.3	19.4	55.2	91.0	18.0	53.8	89.5	16.5	52.2	88.0	15.0	50.7	86.5		
	76	TC	—	110.2	110.2	—	105.6	105.6	—	100.3	100.3	—	94.4	94.4	—	88.0	88.0		
		SHC	—	41.2	76.1	—	39.8	74.7	—	38.2	73.2	—	36.5	71.5	—	34.7	69.7		
	8000 cfm	EA (wb)	58	TC	89.7	89.7	113.9	86.5	86.5	109.6	82.8	82.8	104.7	78.7	78.7	99.3	74.2	74.2	93.4
				SHC	65.6	89.7	113.9	63.4	86.5	109.6	60.8	82.8	104.7	58.0	78.7	99.3	55.0	74.2	93.4
62			TC	89.8	89.8	121.9	86.5	86.5	117.3	82.8	82.8	112.0	78.7	78.7	106.1	74.2	74.2	99.8	
			SHC	57.7	89.8	121.9	55.8	86.5	117.3	53.6	82.8	112.0	51.2	78.7	106.1	48.7	74.2	99.8	
67			TC	92.2	92.2	120.4	88.1	88.1	119.2	83.6	83.6	117.6	78.8	78.8	115.7	77.0	77.0	96.9	
			SHC	39.6	80.0	120.4	38.6	78.9	119.2	37.6	77.6	117.6	36.7	76.2	115.7	30.9	63.9	96.9	
72		TC	101.4	101.4	101.4	96.8	96.8	97.5	91.6	91.6	96.0	85.9	85.9	94.5	79.7	79.7	93.1		
		SHC	17.9	58.3	98.8	16.6	57.0	97.5	15.2	55.6	96.0	13.7	54.1	94.5	12.2	52.7	93.1		
76		TC	—	109.5	109.5	—	104.8	104.8	—	99.3	99.3	—	93.3	93.3	—	86.8	86.8		
		SHC	—	41.0	80.5	—	39.6	79.1	—	38.0	77.5	—	36.3	75.8	—	34.4	73.9		
9000 cfm		EA (wb)	58	TC	90.5	90.5	115.3	87.0	87.0	110.8	83.2	83.2	105.7	78.8	78.8	100.0	74.1	74.1	93.8
				SHC	65.7	90.5	115.3	63.3	87.0	110.8	60.6	83.2	105.7	57.7	78.8	100.0	54.4	74.1	93.8
	62		TC	90.5	90.5	123.5	87.1	87.1	118.7	83.2	83.2	113.1	78.9	78.9	107.0	74.1	74.1	100.4	
			SHC	57.5	90.5	123.5	55.5	87.1	118.7	53.2	83.2	113.1	50.7	78.9	107.0	47.9	74.1	100.4	
	67		TC	91.4	91.4	128.4	87.4	87.4	126.9	83.0	83.0	124.9	80.1	80.1	111.4	75.4	75.4	103.1	
			SHC	39.2	83.8	128.4	38.3	82.6	126.9	37.5	81.2	124.9	35.7	73.6	111.4	33.7	68.4	103.1	
	72	TC	99.9	99.9	104.6	95.2	95.2	103.3	90.0	90.0	101.9	84.1	84.1	100.4	77.9	77.9	99.0		
		SHC	14.6	59.6	104.6	13.3	58.3	103.3	11.9	56.9	101.9	10.5	55.5	100.4	9.2	54.1	99.0		
	76	TC	—	108.1	108.1	—	103.2	103.2	—	97.7	97.7	—	91.6	91.6	—	84.9	84.9		
		SHC	—	40.3	84.2	—	38.9	82.8	—	37.3	81.2	—	35.5	79.4	—	33.7	77.6		

LEGEND

- db — dry bulb
- EA — Entering Air Temperature (°F)
- SHC — Sensible Heat Capacity (1000 Btuh) gross
- TC — Total Capacity (1000 Btuh) gross
- wb — wet bulb

38AXD28/40RLA28 Stage 3 Combination Ratings — 60 Hz

38AXD28/40RLA28			AMBIENT TEMPERATURE (°F)																
			85			95			105			115			125				
			EA (db)			EA (db)			EA (db)			EA (db)			EA (db)				
			75	80	85	75	80	85	75	80	85	75	80	85	75	80	85		
7500 cfm	EA (wb)	58	TC	240.8	240.8	272.6	230.4	230.4	265.2	220.0	220.0	255.4	209.2	209.2	242.9	197.3	197.3	229.0	
			SHC	198.1	235.3	272.6	192.0	228.6	265.2	184.7	220.0	255.4	175.6	209.2	242.9	165.6	197.3	229.0	
		62	TC	265.2	265.2	265.2	252.3	252.3	252.3	238.1	238.1	243.4	222.4	222.4	236.7	205.5	205.5	229.0	
			SHC	176.3	215.6	254.9	170.9	210.2	249.4	165.1	204.2	243.4	158.7	197.7	236.7	151.6	190.3	229.0	
		67	TC	303.5	303.5	303.5	289.4	289.4	289.4	274.0	274.0	274.0	257.0	257.0	257.0	238.8	238.8	238.8	
			SHC	144.5	183.9	223.3	139.2	178.6	217.9	133.5	172.8	212.2	127.4	166.7	206.0	120.9	160.2	199.5	
	72	TC	344.5	344.5	344.5	328.9	328.9	328.9	312.1	312.1	312.1	293.9	293.9	293.9	274.7	274.7	274.7		
		SHC	112.0	151.8	191.6	106.7	146.4	186.2	101.1	140.7	180.4	95.2	134.7	174.3	89.0	128.5	168.0		
	76	TC	—	378.8	378.8	—	361.9	361.9	—	343.8	343.8	—	324.4	324.4	—	304.1	304.1		
		SHC	—	125.5	166.7	—	120.2	161.4	—	114.6	155.6	—	108.8	149.5	—	102.7	143.2		
	8750 cfm	EA (wb)	58	TC	259.8	259.8	300.3	250.1	250.1	289.1	239.3	239.3	276.6	227.4	227.4	262.8	214.5	214.5	247.8
				SHC	219.3	259.8	300.3	211.1	250.1	289.1	202.0	239.3	276.6	192.0	227.4	262.8	181.1	214.5	247.8
62			TC	278.4	278.4	286.7	264.7	264.7	280.7	249.7	249.7	273.9	233.4	233.4	265.6	218.0	218.0	253.2	
			SHC	196.3	241.5	286.7	190.6	235.6	280.7	184.3	229.1	273.9	177.0	221.3	265.6	167.7	210.5	253.2	
67			TC	317.2	317.2	317.2	302.0	302.0	302.0	285.5	285.5	285.5	267.5	267.5	267.5	248.3	248.3	248.3	
			SHC	158.1	203.6	249.0	152.5	197.9	243.3	146.6	192.0	237.3	140.2	185.6	230.9	133.6	178.9	224.2	
72		TC	358.7	358.7	358.7	341.9	341.9	341.9	324.0	324.0	324.0	304.7	304.7	304.7	284.5	284.5	284.5		
		SHC	119.0	164.8	210.6	113.5	159.2	204.9	107.6	153.2	198.8	101.4	146.9	192.4	95.0	140.4	185.8		
76		TC	—	392.9	392.9	—	374.7	374.7	—	355.5	355.5	—	335.0	335.0	—	313.7	313.7		
		SHC	—	133.3	180.8	—	127.7	174.9	—	121.8	168.7	—	115.7	162.2	—	109.3	155.5		
10000 cfm		EA (wb)	58	TC	277.7	277.7	319.9	267.1	267.1	307.8	255.4	255.4	294.2	242.5	242.5	279.4	228.6	228.6	263.4
				SHC	235.4	277.7	319.9	226.5	267.1	307.8	216.6	255.4	294.2	205.7	242.5	279.4	193.9	228.6	263.4
	62		TC	289.3	289.3	316.1	275.1	275.1	309.0	260.3	260.3	298.5	245.0	245.0	287.6	229.0	229.0	275.3	
			SHC	214.8	265.4	316.1	208.5	258.7	309.0	200.2	249.3	298.5	191.8	239.7	287.6	182.8	229.0	275.3	
	67		TC	327.9	327.9	327.9	311.8	311.8	311.8	294.4	294.4	294.4	275.6	275.6	275.6	255.6	255.6	255.6	
			SHC	170.6	221.9	273.2	164.8	216.1	267.4	158.7	209.9	261.2	152.2	203.4	254.5	145.4	196.5	247.5	
	72	TC	369.6	369.6	369.6	351.9	351.9	351.9	333.1	333.1	333.1	313.0	313.0	313.0	292.0	292.0	292.0		
		SHC	124.9	176.5	228.1	119.1	170.6	222.1	113.0	164.5	215.9	106.7	158.0	209.3	100.1	151.3	202.5		
	76	TC	—	403.9	403.9	—	384.8	384.8	—	364.6	364.6	—	343.3	343.3	—	321.1	321.1		
		SHC	—	139.8	192.8	—	133.9	186.7	—	127.8	180.2	—	121.4	173.5	—	114.8	166.6		
	11250 cfm	EA (wb)	58	TC	293.0	293.0	336.8	281.6	281.6	323.7	269.1	269.1	309.3	255.4	255.4	293.5	240.7	240.7	276.6
				SHC	249.3	293.0	336.8	239.6	281.6	323.7	228.9	269.1	309.3	217.3	255.4	293.5	204.8	240.7	276.6
62			TC	298.8	298.8	342.1	285.4	285.4	331.0	270.8	270.8	320.4	255.8	255.8	306.5	241.0	241.0	288.8	
			SHC	231.2	286.7	342.1	222.9	276.9	331.0	214.8	267.6	320.4	205.1	255.8	306.5	193.3	241.0	288.8	
67			TC	336.5	336.5	336.5	319.7	319.7	319.7	301.6	301.6	301.6	282.1	282.1	282.1	261.5	261.5	270.0	
			SHC	182.2	239.4	296.5	176.3	233.4	290.5	170.1	227.1	284.1	163.4	220.3	277.1	156.6	213.3	270.0	
72		TC	378.4	378.4	378.4	360.0	360.0	360.0	340.4	340.4	340.4	319.7	319.7	319.7	298.0	298.0	298.0		
		SHC	129.9	187.2	244.5	124.0	181.2	238.4	117.8	174.9	232.0	111.3	168.2	225.2	104.6	161.4	218.2		
76		TC	—	412.6	412.6	—	392.7	392.7	—	371.8	371.8	—	349.8	349.8	—	326.9	326.9		
		SHC	—	145.2	203.7	—	139.2	197.4	—	132.9	190.8	—	126.3	183.9	—	119.5	176.7		
12500 cfm		EA (wb)	58	TC	306.3	306.3	351.4	294.2	294.2	337.4	280.9	280.9	322.2	266.4	266.4	305.6	251.0	251.0	287.9
				SHC	261.2	306.3	351.4	250.9	294.2	337.4	239.6	280.9	322.2	227.3	266.4	305.6	214.2	251.0	287.9
	62		TC	309.0	309.0	361.9	294.7	294.7	352.4	281.3	281.3	336.3	266.8	266.8	318.9	251.4	251.4	300.5	
			SHC	244.5	303.2	361.9	237.0	294.7	352.4	226.4	281.3	336.3	214.7	266.8	318.9	202.3	251.4	300.5	
	67		TC	343.6	343.6	343.6	326.2	326.2	326.2	307.5	307.5	307.5	287.5	287.5	298.8	266.6	266.6	291.0	
			SHC	193.3	256.0	318.8	187.2	249.9	312.6	180.9	243.5	306.0	174.2	236.5	298.8	167.1	229.1	291.0	
	72	TC	385.6	385.6	385.6	366.5	366.5	366.5	346.4	346.4	346.4	325.1	325.1	325.1	302.9	302.9	302.9		
		SHC	134.2	197.1	260.1	128.2	191.0	253.8	121.9	184.5	247.2	115.3	177.8	240.3	108.6	170.9	233.2		
	76	TC	—	419.8	419.8	—	399.2	399.2	—	377.6	377.6	—	355.0	355.0	—	331.6	331.6		
		SHC	—	149.9	213.8	—	143.7	207.3	—	137.2	200.5	—	130.4	193.3	—	123.5	185.9		

LEGEND

- db — dry bulb
- EA — Entering Air Temperature (°F)
- SHC — Sensible Heat Capacity (1000 Btuh) gross
- TC — Total Capacity (1000 Btuh) gross
- wb — wet bulb

38AXD28/40RLA28 Stage 2 Combination Ratings — 60 Hz

38AXD28/40RLA28			AMBIENT TEMPERATURE (°F)																
			85			95			105			115			125				
			EA (db)			EA (db)			EA (db)			EA (db)			EA (db)				
			75	80	85	75	80	85	75	80	85	75	80	85	75	80	85		
7500 cfm	EA (wb)	58	TC	205.9	205.9	227.5	196.8	196.8	221.2	187.5	187.5	213.6	177.4	177.4	202.0	166.3	166.3	189.3	
			SHC	172.7	200.1	227.5	167.3	194.2	221.2	161.5	187.5	213.6	152.7	177.4	202.0	143.2	166.3	189.3	
		62	TC	218.0	218.0	218.6	207.0	207.0	212.9	195.5	195.5	203.5	183.5	183.5	195.1	170.2	170.2	186.2	
			SHC	157.4	188.0	218.6	152.1	182.5	212.9	144.5	174.0	203.5	137.5	166.3	195.1	130.1	158.2	186.2	
		67	TC	243.2	243.2	243.2	231.5	231.5	231.5	218.5	218.5	218.5	204.2	204.2	204.2	188.6	188.6	188.6	
			SHC	129.9	161.0	192.0	125.1	156.2	187.2	119.9	150.9	181.9	114.3	145.2	176.2	108.2	139.1	169.9	
	72	TC	269.7	269.7	269.7	257.0	257.0	257.0	243.0	243.0	243.0	227.8	227.8	227.8	211.4	211.4	211.4		
		SHC	100.4	131.7	163.0	95.8	127.0	158.2	90.7	121.9	153.0	85.3	116.3	147.4	79.6	110.5	141.4		
	76	TC	—	291.9	291.9	—	278.3	278.3	—	263.4	263.4	—	247.2	247.2	—	229.9	229.9		
		SHC	—	107.9	140.0	—	103.2	135.3	—	98.2	130.2	—	92.9	124.7	—	87.2	118.9		
	8750 cfm	EA (wb)	58	TC	220.2	220.2	250.4	211.3	211.3	240.2	201.3	201.3	229.0	190.2	190.2	216.4	178.2	178.2	202.6
				SHC	189.9	220.2	250.4	182.3	211.3	240.2	173.7	201.3	229.0	164.1	190.2	216.4	153.7	178.2	202.6
62			TC	228.1	228.1	239.1	217.7	217.7	231.9	206.0	206.0	223.8	193.1	193.1	215.2	179.1	179.1	206.0	
			SHC	169.9	204.5	239.1	163.9	197.9	231.9	157.2	190.5	223.8	150.1	182.6	215.2	142.7	174.4	206.0	
67			TC	252.8	252.8	252.8	240.3	240.3	240.3	226.5	226.5	226.5	211.2	211.2	211.2	194.8	194.8	194.8	
			SHC	140.5	177.0	213.5	135.5	172.0	208.5	130.2	166.6	203.1	124.3	160.6	196.9	117.9	154.0	190.1	
72		TC	279.7	279.7	279.7	266.1	266.1	266.1	251.3	251.3	251.3	235.2	235.2	235.2	218.0	218.0	218.0		
		SHC	105.1	141.8	178.5	100.2	136.9	173.5	95.1	131.6	168.1	89.5	125.9	162.3	83.6	119.9	156.2		
76		TC	—	302.0	302.0	—	287.5	287.5	—	271.7	271.7	—	254.6	254.6	—	236.5	236.5		
		SHC	—	113.3	151.1	—	108.5	146.2	—	103.3	140.7	—	97.7	134.8	—	91.9	128.7		
10000 cfm		EA (wb)	58	TC	232.7	232.7	264.3	223.1	223.1	253.5	212.4	212.4	241.3	200.6	200.6	227.9	187.7	187.7	213.2
				SHC	201.0	232.7	264.3	192.7	223.1	253.5	183.5	212.4	241.3	173.3	200.6	227.9	162.2	187.7	213.2
	62		TC	237.5	237.5	258.9	226.5	226.5	251.5	214.3	214.3	243.4	201.0	201.0	234.7	188.0	188.0	222.0	
			SHC	182.2	220.6	258.9	176.1	213.8	251.5	169.5	206.4	243.4	162.7	198.7	234.7	153.9	188.0	222.0	
	67		TC	260.0	260.0	260.0	246.7	246.7	246.7	232.2	232.2	232.2	216.4	216.4	216.4	199.6	199.6	208.1	
			SHC	150.1	192.0	233.9	145.0	186.8	228.5	139.3	180.9	222.5	133.1	174.5	215.8	126.3	167.2	208.1	
	72	TC	287.1	287.1	287.1	272.9	272.9	272.9	257.4	257.4	257.4	240.7	240.7	240.7	222.8	222.8	222.8		
		SHC	108.9	150.8	192.8	103.9	145.8	187.6	98.7	140.4	182.1	93.0	134.6	176.2	87.1	128.5	169.9		
	76	TC	—	309.5	309.5	—	294.1	294.1	—	277.7	277.7	—	260.0	260.0	—	241.1	241.1		
		SHC	—	117.7	160.6	—	112.7	155.4	—	107.4	149.8	—	101.7	143.7	—	95.7	137.4		
	11250 cfm	EA (wb)	58	TC	243.0	243.0	275.8	232.8	232.8	264.3	221.5	221.5	251.5	209.0	209.0	237.3	195.5	195.5	222.0
				SHC	210.1	243.0	275.8	201.3	232.8	264.3	191.5	221.5	251.5	180.8	209.0	237.3	169.1	195.5	222.0
62			TC	245.2	245.2	277.9	233.8	233.8	270.3	221.7	221.7	261.6	209.2	209.2	246.8	195.7	195.7	230.9	
			SHC	194.1	236.0	277.9	188.0	229.2	270.3	181.7	221.7	261.6	171.6	209.2	246.8	160.5	195.7	230.9	
67			TC	265.3	265.3	265.3	251.6	251.6	251.6	236.7	236.7	240.5	220.6	220.6	233.0	203.6	203.6	222.8	
			SHC	158.9	205.8	252.7	153.6	200.3	247.0	147.7	194.1	240.5	141.1	187.1	233.0	133.1	178.0	222.8	
72		TC	292.8	292.8	292.8	278.1	278.1	278.1	262.1	262.1	262.1	244.8	244.8	244.8	226.5	226.5	226.5		
		SHC	112.1	159.1	206.2	107.1	154.0	200.9	101.8	148.5	195.3	96.1	142.7	189.3	90.1	136.5	182.9		
76		TC	—	315.1	315.1	—	299.3	299.3	—	282.2	282.2	—	263.9	263.9	—	244.6	244.6		
		SHC	—	121.4	169.2	—	116.2	163.8	—	110.8	158.0	—	105.0	151.8	—	98.9	145.3		
12500 cfm		EA (wb)	58	TC	251.6	251.6	285.5	240.9	240.9	273.4	229.1	229.1	259.9	216.0	216.0	245.1	202.0	202.0	229.1
				SHC	217.8	251.6	285.5	208.5	240.9	273.4	198.2	229.1	259.9	187.0	216.0	245.1	174.8	202.0	229.1
	62		TC	252.1	252.1	295.0	241.2	241.2	284.3	229.3	229.3	270.3	216.3	216.3	255.0	202.1	202.1	238.3	
			SHC	205.4	250.2	295.0	198.0	241.2	284.3	188.3	229.3	270.3	177.6	216.3	255.0	166.0	202.1	238.3	
	67		TC	269.6	269.6	270.4	255.6	255.6	264.2	240.5	240.5	257.0	224.2	224.2	247.4	207.7	207.7	235.5	
			SHC	167.0	218.7	270.4	161.5	212.9	264.2	155.3	206.1	257.0	147.8	197.6	247.4	139.2	187.4	235.5	
	72	TC	297.3	297.3	297.3	282.2	282.2	282.2	265.7	265.7	265.7	248.1	248.1	248.1	229.4	229.4	229.4		
		SHC	114.9	166.9	218.8	109.8	161.7	213.5	104.5	156.1	207.8	98.8	150.2	201.7	92.8	144.1	195.3		
	76	TC	—	319.6	319.6	—	303.3	303.3	—	285.8	285.8	—	267.1	267.1	—	247.4	247.4		
		SHC	—	124.3	176.9	—	119.1	171.4	—	113.6	165.5	—	107.7	159.2	—	101.5	152.4		

LEGEND

- db — dry bulb
- EA — Entering Air Temperature (°F)
- SHC — Sensible Heat Capacity (1000 Btuh) gross
- TC — Total Capacity (1000 Btuh) gross
- wb — wet bulb

38AXD28/40RLA28 Stage 1 Combination Ratings — 60 Hz

38AXD28/40RLA28				AMBIENT TEMPERATURE (°F)															
				85			95			105			115			125			
				EA (db)			EA (db)			EA (db)			EA (db)			EA (db)			
				75	80	85	75	80	85	75	80	85	75	80	85	75	80	85	
7500 cfm	EA (wb)	58	TC	85.6	85.6	102.1	82.2	82.2	98.5	78.4	78.4	93.9	74.2	74.2	88.9	69.4	69.4	83.3	
			SHC	68.4	85.3	102.1	65.9	82.2	98.5	62.8	78.4	93.9	59.4	74.2	88.9	55.6	69.4	83.3	
		62	TC	87.6	87.6	87.6	83.7	83.7	86.1	78.9	78.9	83.4	74.1	74.1	82.0	69.2	69.2	80.8	
			SHC	53.5	70.2	86.9	51.6	68.8	86.1	49.0	66.2	83.4	46.8	64.4	82.0	45.2	63.0	80.8	
		67	TC	94.0	94.0	94.0	89.0	89.0	89.0	84.9	84.9	84.9	79.5	79.5	79.5	73.7	73.7	73.7	
			SHC	44.9	59.0	73.0	42.2	56.1	70.0	39.8	55.6	71.5	37.1	53.0	69.0	34.4	50.7	67.0	
	72	TC	101.3	101.3	101.3	96.8	96.8	96.8	91.6	91.6	91.6	85.9	85.9	85.9	79.8	79.8	79.8		
		SHC	20.1	47.6	75.1	18.9	46.4	73.9	17.2	44.7	72.2	15.3	42.8	70.3	26.6	40.5	54.4		
	76	TC	—	108.0	108.0	—	103.1	103.1	—	97.8	97.8	—	91.8	91.8	—	85.3	85.3		
		SHC	—	43.1	70.6	—	41.3	68.8	—	37.3	64.8	—	35.3	62.8	—	32.2	59.7		
	8750 cfm	EA (wb)	58	TC	90.4	90.4	107.6	86.7	86.7	103.2	82.5	82.5	98.2	78.0	78.0	92.9	72.9	72.9	86.8
				SHC	73.2	90.4	107.6	70.2	86.7	103.2	66.8	82.5	98.2	63.2	78.0	92.9	59.0	72.9	86.8
62			TC	89.7	89.7	93.7	86.0	86.0	94.4	80.8	80.8	92.0	78.7	78.7	94.6	73.9	73.9	86.0	
			SHC	55.6	74.6	93.7	54.4	74.4	94.4	52.0	72.0	92.0	55.5	75.1	94.6	52.7	69.4	86.0	
67			TC	96.9	96.9	96.9	92.2	92.2	92.2	87.1	87.1	87.1	82.1	82.1	82.1	80.8	80.8	96.0	
			SHC	45.1	62.8	80.4	42.7	60.6	78.5	40.4	58.8	77.2	38.2	57.5	76.8	68.0	82.0	96.0	
72		TC	104.6	104.6	104.6	99.8	99.8	99.8	94.3	94.3	94.3	88.6	88.6	88.6	82.1	82.1	82.1		
		SHC	17.3	50.3	83.3	15.8	48.8	81.8	31.6	46.7	61.9	28.0	45.1	62.2	25.0	42.9	60.8		
76		TC	—	111.6	111.6	—	106.4	106.4	—	100.7	100.7	—	94.3	94.3	—	87.4	87.4		
		SHC	—	41.6	74.6	—	39.9	72.9	—	36.9	69.9	—	34.7	67.7	—	33.1	66.1		
10000 cfm		EA (wb)	58	TC	93.8	93.8	111.3	89.8	89.8	106.6	85.3	85.3	101.3	80.7	80.7	95.8	75.2	75.2	89.4
				SHC	76.3	93.8	111.3	73.0	89.8	106.6	69.3	85.3	101.3	65.5	80.7	95.8	61.1	75.2	89.4
	62		TC	91.1	91.1	100.2	88.5	88.5	103.9	86.1	86.1	102.1	81.7	81.7	95.8	75.2	75.2	94.0	
			SHC	57.7	79.0	100.2	58.8	81.4	103.9	62.6	82.4	102.1	58.9	77.4	95.8	56.5	75.2	94.0	
	67		TC	99.6	99.6	99.6	94.6	94.6	94.6	89.0	89.0	89.0	83.2	83.2	83.2	76.9	76.9	81.4	
			SHC	46.0	67.1	88.2	43.9	65.3	86.7	41.3	62.6	83.9	39.0	60.5	82.1	38.2	59.8	81.4	
	72	TC	107.2	107.2	107.2	102.1	102.1	102.1	96.4	96.4	96.4	90.3	90.3	90.3	83.6	83.6	83.6		
		SHC	35.2	52.4	69.7	32.2	50.8	69.3	29.5	48.9	68.3	26.8	46.9	67.0	24.0	44.6	65.2		
	76	TC	—	114.1	114.1	—	108.7	108.7	—	102.6	102.6	—	96.0	96.0	—	88.8	88.8		
		SHC	—	40.8	79.3	—	38.5	77.0	—	37.3	75.8	—	35.5	74.0	—	33.6	50.8		
	11250 cfm	EA (wb)	58	TC	96.2	96.2	114.1	91.9	91.9	109.0	87.6	87.6	103.8	82.4	82.4	97.7	76.9	76.9	91.2
				SHC	78.4	96.2	114.1	74.9	91.9	109.0	71.3	87.6	103.8	67.1	82.4	97.7	62.6	76.9	91.2
62			TC	94.5	94.5	112.5	92.9	92.9	109.7	88.5	88.5	102.2	82.4	82.4	102.8	76.9	76.9	96.0	
			SHC	65.5	89.0	112.5	67.6	88.7	109.7	63.5	82.8	102.2	62.1	82.4	102.8	57.9	76.9	96.0	
67			TC	100.9	100.9	100.9	95.8	95.8	95.8	90.3	90.3	90.3	84.1	84.1	86.6	78.0	78.0	85.7	
			SHC	46.7	70.0	93.3	44.5	67.8	91.2	42.3	66.0	89.7	39.7	63.2	86.6	37.5	61.6	85.7	
72		TC	109.0	109.0	109.0	103.8	103.8	103.8	98.0	98.0	98.0	91.6	91.6	91.6	84.7	84.7	84.7		
		SHC	33.2	54.0	74.9	30.8	52.4	73.9	28.4	50.5	72.7	25.8	48.4	71.0	23.2	46.2	69.2		
76		TC	—	115.8	115.8	—	110.2	110.2	—	104.0	104.0	—	97.3	97.3	—	89.9	89.9		
		SHC	—	40.6	84.6	—	39.4	83.4	—	37.8	81.8	—	35.9	55.0	—	33.7	55.0		
12500 cfm		EA (wb)	58	TC	98.1	98.1	116.1	93.8	93.8	111.0	89.3	89.3	105.7	84.0	84.0	99.5	78.5	78.5	93.0
				SHC	80.2	98.1	116.1	76.6	93.8	111.0	72.9	89.3	105.7	68.6	84.0	99.5	64.1	78.5	93.0
	62		TC	99.7	99.7	116.2	94.1	94.1	117.0	89.3	89.3	111.1	84.0	84.0	104.6	78.4	78.4	97.6	
			SHC	72.2	94.2	116.2	71.1	94.1	117.0	67.5	89.3	111.1	63.5	84.0	104.6	59.2	78.4	97.6	
	67		TC	102.2	102.2	102.2	97.1	97.1	97.4	91.1	91.1	92.0	85.1	85.1	93.2	78.7	78.7	91.9	
			SHC	47.9	73.3	98.8	45.9	71.6	97.4	41.1	66.6	92.0	41.5	67.3	93.2	39.3	65.6	91.9	
	72	TC	110.6	110.6	110.6	105.2	105.2	105.2	99.2	99.2	99.2	92.7	92.7	92.7	85.6	85.6	85.6		
		SHC	32.0	55.6	79.2	29.8	53.9	78.1	27.5	52.0	76.6	25.1	49.9	74.8	22.6	47.8	73.0		
	76	TC	—	117.4	117.4	—	111.6	111.6	—	105.3	105.3	—	98.4	98.4	—	90.9	90.9		
		SHC	—	41.2	90.7	—	39.7	89.2	—	37.9	59.1	—	35.9	58.9	—	33.6	57.7		

LEGEND

- db — dry bulb
- EA — Entering Air Temperature (°F)
- SHC — Sensible Heat Capacity (1000 Btuh) gross
- TC — Total Capacity (1000 Btuh) gross
- wb — wet bulb

38AXZ 07-14 without Powered Convenience Outlet

UNIT SIZE	NUMBER OF STAGES	V-Ph-Hz	VOLTAGE RANGE		COMPRESSOR NO. 1		COMPRESSOR NO. 2		OFM		POWER SUPPLY		DISCONNECT SIZE	
			Min	Max	RLA	LRA	RLA	LRA	Qty	FLA (ea)	MCA	Fuse or HACR Breaker	FLA	LRA
07	2	208/230-3-60	187	253	18.9	162	—	—	2	1.5	27/27	45/45	25/25	168/168
		460-3-60	414	506	9.6	71	—	—	2	0.8	14	20	13	75
		575-3-60	518	633	6.6	58	—	—	2	0.7	10	15	9	62
08	2	208/230-3-60	187	253	26.6	191	—	—	2	1.5	37/37	60/60	34/34	197/197
		460-3-60	414	506	11.6	95	—	—	2	0.8	17	25	15	99
		575-3-60	518	633	9.9	65	—	—	2	0.7	14	20	13	69
12	2	208/230-3-60	187	253	28.5	255	—	—	2	1.5	39/39	60/60	36/36	261/261
		460-3-60	414	506	14.9	123	—	—	2	0.8	21	30	19	127
		575-3-60	518	633	12.3	94	—	—	2	0.7	17	25	16	98
14	2	208/230-3-60	187	253	21.1	157	21.1	157	2	1.5	51/51	60/60	52/52	320/320
		460-3-60	414	506	9.1	75	9.1	75	2	0.8	23	30	23	154
		575-3-60	518	633	7.7	48	7.7	48	2	0.7	19	25	19	100

38AXZ 07-14 with Powered Convenience Outlet

UNIT SIZE	NUMBER OF STAGES	V-Ph-Hz	VOLTAGE RANGE		COMPRESSOR NO. 1		COMPRESSOR NO. 2		OFM		POWER SUPPLY		DISCONNECT SIZE	
			Min	Max	RLA	LRA	RLA	LRA	Qty	FLA (ea)	MCA	Fuse or HACR Breaker	FLA	LRA
07	2	208/230-3-60	187	253	18.9	162	—	—	2	1.5	32/32	50/50	31/31	173/173
		460-3-60	414	506	9.6	71	—	—	2	0.8	16	25	15	77
		575-3-60	518	633	6.6	58	—	—	2	0.7	12	15	11	64
08	2	208/230-3-60	187	253	26.6	191	—	—	2	1.5	42/42	60/60	40/40	202/202
		460-3-60	414	506	11.6	95	—	—	2	0.8	19	25	18	101
		575-3-60	518	633	9.9	65	—	—	2	0.7	16	25	15	71
12	2	208/230-3-60	187	253	28.5	255	—	—	2	1.5	44/44	60/60	42/42	266/266
		460-3-60	414	506	14.9	123	—	—	2	0.8	23	30	22	129
		575-3-60	518	633	12.3	94	—	—	2	0.7	19	30	18	100
14	2	208/230-3-60	187	253	21.1	157	21.1	157	2	1.5	56/56	70/70	58/58	325/325
		460-3-60	414	506	9.1	75	9.1	75	2	0.8	25	30	25	156
		575-3-60	518	633	7.7	48	7.7	48	2	0.7	21	25	21	102

LEGEND

FLA — Full Load Amps
LRA — Locked Rotor Amps
OFM — Outdoor Fan Motor

38AXZ 16, 25 without Powered Convenience Outlet

UNIT SIZE	NUMBER OF STAGES	NOMINAL POWER SUPPLY V-Ph-Hz	VOLTAGE RANGE		COMPRESSOR No. 1		COMPRESSOR No. 2		OFM		POWER SUPPLY		DISCONNECT SIZE	
			Min	Max	RLA	LRA	RLA	LRA	Qty	FLA (ea)	MCA	Fuse or HACR Brkr	FLA	LRA
16	2	208/230-3-60	187	253	28.9	179	28.9	179	3	1.5	70/70	90/90	72/72	367/367
	2	460-3-60	414	506	12.0	103	12.0	103	3	0.8	29	40	30	212
	2	575-3-60	518	633	9.4	78	9.4	78	3	0.7	23	30	24	162
25	2	208/230-3-60	187	253	30.4	255	30.4	255	4	1.5	74/74	100/100	77/77	522/522
	2	460-3-60	414	506	14.3	123	14.3	123	4	0.8	35	45	37	254
	2	575-3-60	518	633	11.4	94	11.4	94	4	0.7	28	35	29	196

38AXZ 16, 25 with Powered Convenience Outlet

UNIT SIZE	NUMBER OF STAGES	NOMINAL POWER SUPPLY V-Ph-Hz	VOLTAGE RANGE		COMPRESSOR No. 1		COMPRESSOR No. 2		OFM		POWER SUPPLY		DISCONNECT SIZE	
			Min	Max	RLA	LRA	RLA	LRA	Qty	FLA (ea)	MCA	Fuse or HACR Brkr	FLA	LRA
16	2	208/230-3-60	187	253	28.9	179	28.9	179	3	1.5	74/74	100/100	77/77	372/372
	2	460-3-60	414	506	12.0	103	12.0	103	3	0.8	32	40	33	214
	2	575-3-60	518	633	9.4	78	9.4	78	3	0.7	25	30	26	164
25	2	208/230-3-60	187	253	30.4	255	30.4	255	4	1.5	79/79	100/100	82/82	527/527
	2	460-3-60	414	506	14.3	123	14.3	123	4	0.8	38	50	39	256
	2	575-3-60	518	633	11.4	94	11.4	94	4	0.7	30	40	31	198

38AXD 12-14 without Powered Convenience Outlet

UNIT SIZE	NUMBER OF STAGES	NOMINAL POWER SUPPLY V-Ph-Hz	VOLTAGE RANGE		COMPRESSOR No. 1		COMPRESSOR No. 2		OFM		POWER SUPPLY		DISCONNECT SIZE	
			Min	Max	RLA	LRA	RLA	LRA	Qty	FLA (ea)	MCA	Fuse or HACR Brkr	FLA	LRA
12	3	208/230-3-60	187	253	14.0	150	18.6	155	2	1.5	41/41	50/50	41/41	311/311
	3	460-3-60	414	506	6.3	58	8.3	58	2	0.8	19	25	19	120
	3	575-3-60	518	633	5.8	48	7.7	48	2	0.7	17	20	17	100
14	3	208/230-3-60	187	253	18.9	162	21.1	157	2	1.5	49/49	60/60	49/49	325/325
	3	460-3-60	414	506	9.6	71	9.1	75	2	0.8	23	30	23	150
	3	575-3-60	518	633	6.6	58	7.7	48	2	0.7	18	25	18	110

38AXD 12-14 with Powered Convenience Outlet

UNIT SIZE	NUMBER OF STAGES	NOMINAL POWER SUPPLY V-Ph-Hz	VOLTAGE RANGE		COMPRESSOR No. 1		COMPRESSOR No. 2		OFM		POWER SUPPLY		DISCONNECT SIZE	
			Min	Max	RLA	LRA	RLA	LRA	Qty	FLA (ea)	MCA	Fuse or HACR Brkr	FLA	LRA
12	3	208/230-3-60	187	253	14.0	150	18.6	155	2	1.5	46/46	60/60	46/46	316/316
	3	460-3-60	414	506	6.3	58	8.3	58	2	0.8	21	25	21	122
	3	575-3-60	518	633	5.8	48	7.7	48	2	0.7	19	25	19	102
14	3	208/230-3-60	187	253	18.9	162	21.1	157	2	1.5	54/54	60/60	55/55	330/330
	3	460-3-60	414	506	9.6	71	9.1	75	2	0.8	25	30	26	152
	3	575-3-60	518	633	6.6	58	7.7	48	2	0.7	20	25	20	112

LEGEND

- HACR** — Heating, Air Conditioning and Refrigeration
- FLA** — Full Load Amps
- LRA** — Locked Rotor Amps
- MCA** — Minimum Circuit Amps
- OFM** — Outdoor Fan Motor
- RLA** — Rated Load Amps

38AXD 16-28 without Powered Convenience Outlet

UNIT SIZE	NUMBER OF STAGES	NOMINAL POWER SUPPLY V-Ph-Hz	VOLTAGE RANGE		COMPRESSOR No. 1		COMPRESSOR No. 2		OFM		POWER SUPPLY		DISCONNECT SIZE	
			Min	Max	RLA	LRA	RLA	LRA	Qty	FLA (ea)	MCA	Fuse or HACR Brkr	FLA	LRA
16	3	208/230-3-60	187	253	26.9	191	29.2	179	3	1.5	68/68	90/90	70/70	379/379
	3	460-3-60	414	506	11.7	95	12.1	103	3	0.8	29	40	30	204
	3	575-3-60	518	633	10.0	65	9.5	78	3	0.7	24	30	25	149
25	3	208/230-3-60	187	253	29.8	255	28.9	255	4	1.5	72/72	100/100	74/74	522/522
	3	460-3-60	414	506	15.1	123	13.7	123	4	0.8	36	50	37	254
	3	575-3-60	518	633	12.9	94	10.9	94	4	0.7	30	40	31	196
28	3	208/230-3-60	187	253	34.3	255	41.9	270	4	1.5	93/93	125/125	95/95	537/537
	3	460-3-60	414	506	16.8	140	20.0	147	4	0.8	45	60	46	295
	3	575-3-60	518	633	13.4	108	14.1	109	4	0.7	34	45	35	225

38AXD 16-28 with Powered Convenience Outlet

UNIT SIZE	NUMBER OF STAGES	NOMINAL POWER SUPPLY V-Ph-Hz	VOLTAGE RANGE		COMPRESSOR No. 1		COMPRESSOR No. 2		OFM		POWER SUPPLY		DISCONNECT SIZE	
			Min	Max	RLA	LRA	RLA	LRA	Qty	FLA (ea)	MCA	Fuse or HACR Brkr	FLA	LRA
16	3	208/230-3-60	187	253	26.9	191	29.2	179	3	1.5	73/73	100/100	75/75	384/384
	3	460-3-60	414	506	11.7	95	12.1	103	3	0.8	31	40	33	206
	3	575-3-60	518	633	10.0	65	9.5	78	3	0.7	26	30	27	151
25	3	208/230-3-60	187	253	29.8	255	28.9	255	4	1.5	77/77	100/100	80/80	527/527
	3	460-3-60	414	506	15.1	123	13.7	123	4	0.8	38	50	39	256
	3	575-3-60	518	633	12.9	94	10.9	94	4	0.7	32	40	33	198
28	3	208/230-3-60	187	253	34.3	255	41.9	270	4	1.5	98/98	125/125	100/100	542/542
	3	460-3-60	414	506	16.8	140	20.0	147	4	0.8	47	60	49	297
	3	575-3-60	518	633	13.4	108	14.1	109	4	0.7	36	45	37	227

LEGEND

HACR	— Heating, Air Conditioning and Refrigeration
FLA	— Full Load Amps
LRA	— Locked Rotor Amps
MCA	— Minimum Circuit Amps
OFM	— Outdoor Fan Motor
RLA	— Rated Load Amps

Operating limits

- Maximum outdoor temperature..... 125°F
 Minimum return-air temperature (4ORLA)..... 55°F
 Maximum return-air temperature (4ORLA)..... 95°F
 Range of acceptable saturation
 suction temperature..... 20 to 50°F
 Maximum discharge temperature..... 275°F
 Minimum discharge superheat..... 60°F
- Select air handler at no less than 300 cfm/ton (nominal condensing unit capacity).
 - Total combined draw of the field-supplied liquid line solenoid valve and air handler fan contactor must not exceed 22 va. If the specified va must be exceeded, use a remote relay to control the load.

Minimum Outdoor-Air Operating Temperature

UNIT 38AX	MAXIMUM OUTDOOR TEMP (°F)	
	Std	With Low Ambient Control ^a
Z07	35	
Z08	35	
Z12	35	
Z14	35	
Z16	35	
Z25	35	-20
D12	35	
D14	35	
D16	35	
D25	35	
D28	35	

NOTE(S):

- Wind baffles (field-supplied and field-installed) are recommended for all units with low ambient control. Refer to Low Ambient Temperature Control Installation Instructions for additional information.

Refrigerant piping

IMPORTANT: Do not bury refrigerant piping underground.

It is recommended that the refrigerant piping for all commercial split systems include a liquid line solenoid valve, a liquid line filter drier and a sight glass.

For refrigerant lines longer than 75 lineal ft, a liquid line solenoid valve installed at the indoor unit and a suction accumulator are required. Refer to the Refrigerant Specialties Part Numbers table.

Refrigerant Specialties Part Numbers

LIQUID LINE SIZE (in.)	LIQUID LINE SOLENOID VALVE (LLSV)	LLSV COIL	SIGHT GLASS
3/8	EF680033	EF680037	KM680008
1/2	EF680035	EF680037	KM680004
5/8	EF680036	EF680037	KM680005

Commercial Air-Cooled Condensing Units HVAC Guide Specifications

Size Range: **6 to 25 Tons**

Carrier Model Numbers: **38AXZ, Single Circuit (07-25 Models) 38AXD, Dual Circuit (12-28 Models)**

Part 1 — GENERAL

1.01 SYSTEM DESCRIPTION

Outdoor-mounted, air-cooled condensing unit suitable for on-the-ground or rooftop installation. Unit shall consist of a hermetic scroll air-conditioning compressor(s) assembly, an air-cooled coil, propeller-type condenser fans, and a control box. Unit shall be used in a refrigeration circuit matched with a packaged air-handling unit.

1.02 QUALITY ASSURANCE

- A. Unit shall be rated in accordance with AHRI Standard 340/360.
- B. Unit construction shall be designed to conform to ASHRAE 15.
- C. Unit shall be constructed in accordance with UL Standard 60335-1 and 60335-2-40, including testing to withstand rain and shall carry the UL and UL, Canada label.
- D. Unit cabinet shall be capable of withstanding 500-hour salt spray exposure per ASTM B117 (scribed specimen).
- E. Air-cooled condenser coils for hermetic scroll compressor units 38AXZ and 38AXD shall be leak tested at 150 psig, and pressure tested at 650 psig.
- F. Unit shall be manufactured in a facility registered to ISO 9001:2015 manufacturing quality standard.

1.03 DELIVERY, STORAGE, AND HANDLING

Unit shall be shipped as single package only, and shall be stored and handled according to unit manufacturer's recommendations.

1.04 WARRANTY (FOR INCLUSION BY SPECIFYING ENGINEER.)

Part 2 — PRODUCTS

2.01 EQUIPMENT

A. General:

Factory-assembled, single piece, air-cooled condensing unit. Contained within the unit enclosure shall be all factory wiring, piping, controls, compressor, holding charge, and special features required prior to field start-up.

Unit shall use Puron Advance™ (R-454B) refrigerant.

B. Unit Cabinet:

1. Unit cabinet shall be constructed of galvanized steel, bonderized and coated with a pre-painted baked enamel finish.
2. A heavy-gauge roll-formed perimeter base rail with forklift slots and lifting holes shall be provided to facilitate rigging.

C. Condenser Fans:

1. Condenser fans shall be direct driven, propeller type, discharging air vertically upward.
2. Fan blades shall be balanced.
3. Condenser fan discharge openings shall be equipped with PVC-coated steel wire safety guards.
4. Condenser fan and motor shaft shall be corrosion resistant.

D. Compressor:

1. Compressor shall be of the hermetic scroll type.
2. Compressor shall be mounted on rubber grommets.
3. Compressors shall include overload protection.
4. Compressors shall be equipped with a crank-case heater.
5. Compressor shall be equipped with internal high pressure and high temperature protection.

E. Condenser Coils:

1. Standard aluminum fin - copper tube coils:
 - a. Standard evaporator and condenser coils shall have aluminum lanced plate fins mechanically bonded to seamless internally grooved copper tubes with all joints brazed.
 - b. Evaporator coils shall be leak tested to 150 psig, pressure tested to 450 psig, and qualified to UL 60335-2-40 burst test at 1775 psig.
 - c. Condenser coils shall be leak tested to 150 psig, pressure tested to 650 psig, and qualified to UL 60335-2-40 burst test at 1980 psig.
2. Optional copper-fin evaporator and condenser coils:
 - a. Shall be constructed of copper fins mechanically bonded to copper tubes and copper tube sheets.
 - b. Galvanized steel tube sheets shall not be acceptable.
 - c. A polymer strip shall prevent coil assembly from contacting the sheet metal coil pan to minimize potential for galvanic corrosion between coil and pan.
3. Optional e-coated aluminum-fin evaporator and condenser coils:
 - a. Shall have a flexible epoxy polymer coating uniformly applied to all coil surface areas without material bridging between fins.
 - b. Coating process shall ensure complete coil encapsulation of tubes, fins and headers.

- c. Color shall be high gloss black with gloss per ASTM D523-89.
- d. Uniform dry film thickness from 0.8 to 1.2 mil on all surface areas including fin edges.
- e. Superior hardness characteristics of 2H per ASTM D3363-92A and cross-hatch adhesion of 4B-5B per ASTM D3359-93.
- f. Impact resistance shall be up to 160 in.-lb (ASTM D2794-93).
- g. Humidity and water immersion resistance shall be up to minimum 1000 and 250 hours respectively (ASTM D2247-92 and ASTM D870-92).
- h. Corrosion durability shall be confirmed through testing to be no less than 1000 hours salt spray per ASTM B117-90.

F. Refrigeration Components:

Refrigeration circuit components shall include liquid line service valve, suction line service valve, a full charge of compressor oil, and a partial holding charge of refrigerant.

G. Controls and Safeties:

- 1. Minimum control functions shall include:
 - a. Control wire terminal blocks.
 - b. Compressor lockout on auto-reset safety until reset from thermostat.
 - c. Each unit shall utilize the Comfort Alert™¹ Diagnostic Board that provides:
 - 1) System Pressure Trip fault code indication
 - 2) Short Cycling fault code indication
 - 3) Locked Rotor fault code indication
 - 4) Open Circuit fault code indication
 - 5) Reverse Phase 3 fault code indication
 - 6) Welded Contactor fault code indication
 - 7) Low Voltage fault code indication
 - 8) Anti-short cycle protection
 - 9) Phase reversal protection
 - d. Minimum safety devices which are equipped with automatic reset (after resetting first at thermostat), shall include:
 - 1) High discharge pressure cutout.
 - 2) Low pressure cutout.
 - e. Designed to integrate with A2L Refrigerant Leak detection system onboard 40RL products to enable unit shutdown in event of a leak.

H. Operating Characteristics:

- 1. The capacity of the condensing unit shall meet or exceed _____ Btuh at a suction temperature of _____ °F/C. The power consumption at full load shall not exceed _____ kW.

- 2. The combination of the condensing unit and the evaporator or fan coil unit shall have a total net cooling capacity of _____ Btuh or greater at conditions of _____ cfm entering-air temperature at the evaporator at _____ °F/C wet bulb and _____ °F/C dry bulb, and air entering the condensing unit at _____ °F/C.
- 3. The system shall have an IEER of _____ Btuh/Watt or greater at standard AHRI conditions.
- 4. Standard unit shall be capable to operate up to 125°F (52°C) and down to 40°F (4°C)

I. Electrical Requirements:

- 1. Nominal unit electrical characteristics shall be _____ v, 3-ph, _____ Hz. The unit shall be capable of satisfactory operation within voltage limits of _____ v to _____ v.
- 2. Unit electrical power shall be single-point connection.
- 3. Unit control circuit shall contain a 24-v transformer for unit control.

J. Special Features:

- 1. Low-Ambient Temperature Control:

A low-ambient temperature control shall be available as a factory-installed option or as a field-installed accessory. This low-ambient control shall regulate speed of the condenser-fan motors in response to the saturated condensing temperature of the unit. The control shall maintain correct condensing pressure at outdoor temperatures down to -20°F (-29°C).
- 2. Unit-Mounted, Non-Fused Disconnect Switch:

Switch shall be factory-installed and internally mounted. NEC and UL-approved non-fused switch shall provide unit power shutoff. Switch shall be accessible from outside the unit and shall provide power off lockout capability. Non-fused disconnect cannot be used when unit MOCP electrical rating exceeds 80 amps.
- 3. Thermostat Controls:
 - a. Programmable multi-stage thermostat shall have 7-day clock, holiday scheduling, large backlit display, remote sensor capability, and Title 24 compliance.
 - b. Commercial Electronic Thermostat shall have 7-day time clock, auto-changeover, multi-stage capability, and large LCD (liquid crystal display) temperature display.
- 4. Louvered Hail Guard Package:

Louvered hail guard package shall protect coils against damage from hail and other flying debris.
- 5. Condenser Coil Grille:

Grille shall add decorative appearance to unit and protect condenser coil from large objects and vandalism.

1. Third-party trademarks and logos are the property of their respective owners.

