



HEATING & COOLING

Product Data

**VA3B
VB5B
VC5B**

Heat Recovery Ventilators

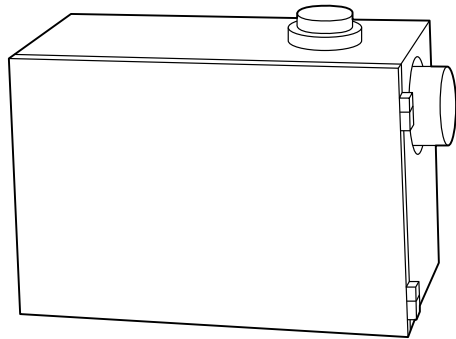

VA3B

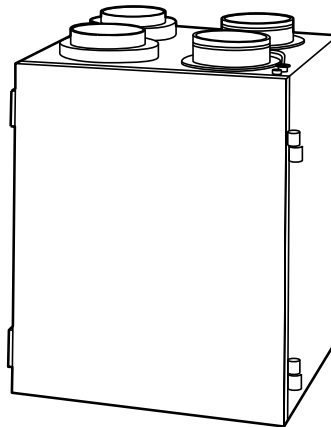

VB5B

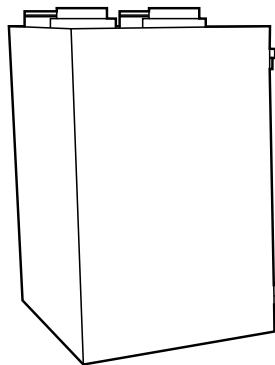

VC5B

The Heat Recovery Ventilation (HRV) system offered by Carrier is the finest unit on the market today. The VA3B, VB5B, and VC5B provide efficient and cost-effective heat recovery during the heating season when needed most.

As temperatures drop below 23°F (-5°C), indoor air is recirculated periodically through the heat exchanger core to prevent frost from forming. Competitors' methods of supplementary electric defrost waste energy. Unlike rotary wheel heat exchangers which mix air streams, these cross flow or counterflow heat exchangers ensure that there is no mixing of the stale air stream with the fresh outdoor air stream.

A filter installed on the incoming outdoor air stream removes large airborne particles from the intake air stream before they enter the heat exchanger and reduces the maintenance required.

The units' acoustically engineered design makes them the quietest on the market and ensures that comfort is felt, not heard.

Unlatching 2 suitcase style latches allows easy removal of the filters and core for cleaning.

FEATURES

- Energy saving defrost cycle
- Cross flow, counterflow heat exchangers
- Two filters on incoming outdoor air stream to protect the HRV core
- Acoustical design
- No-tools maintenance
- Polypropylene heat exchanger core

Model number nomenclature

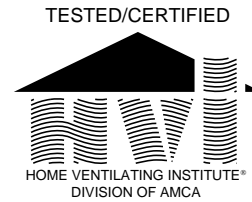
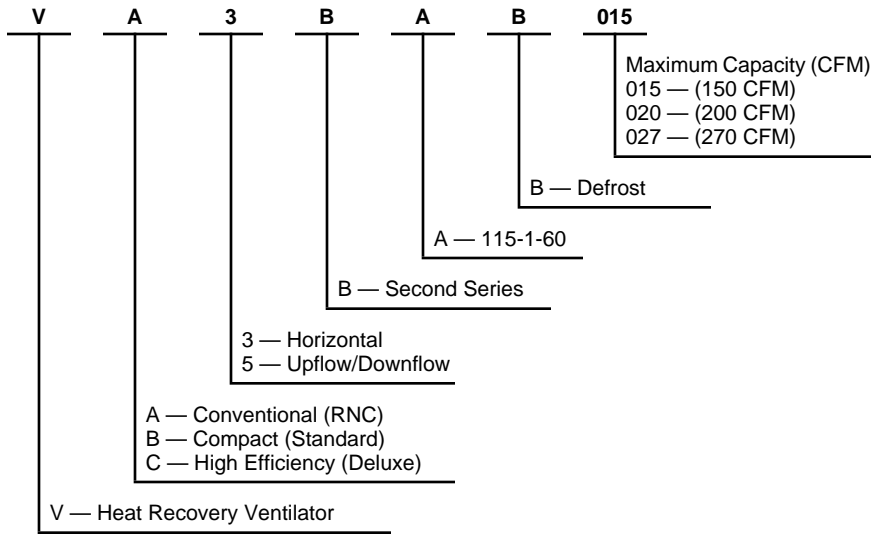

Climate Map for Energy and Heat Recovery Ventilators

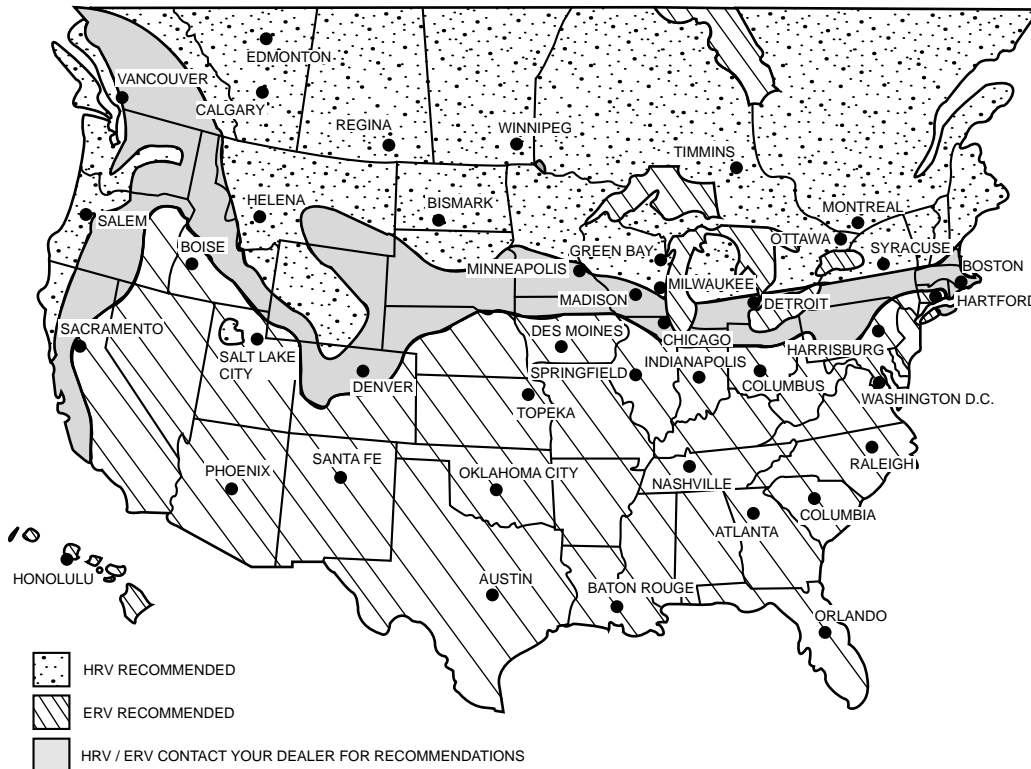

INFORMATION BASED ON AIRPORT 10-YEAR TEMPERATURE DATA & ARI HEATING AND COOLING LOAD HOURS

Controls and accessories part no. nomenclature

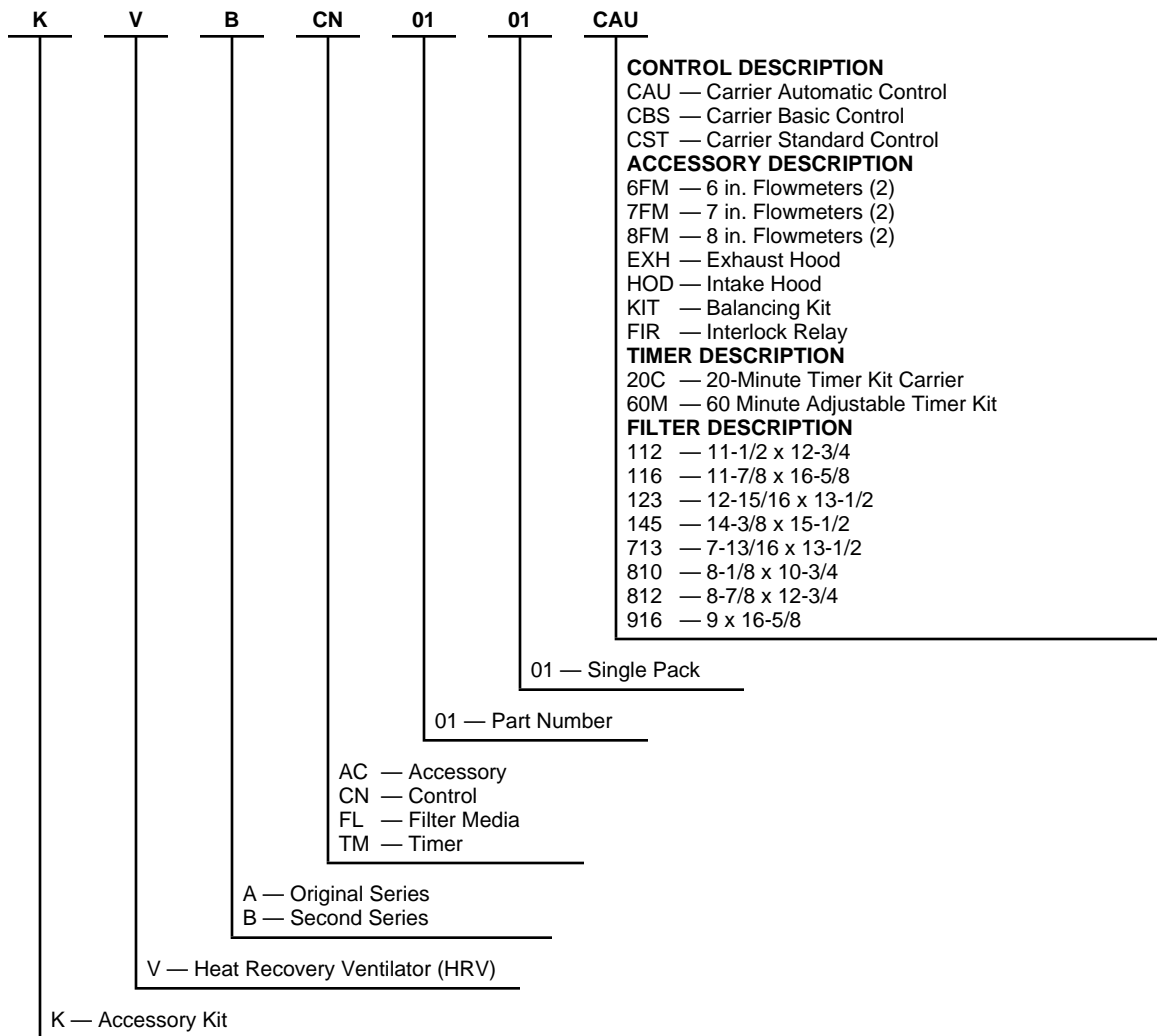

Accessories

Kit Number	Description	Where Used
KVBCN0101CBS	Basic HRV Control	Used with all HRVs
KVBCN0101CST	Standard HRV Control	Used with all HRVs
KVBCN0101CAU	Automatic HRV Control	Used with all VB5B and VC5B
KVAAC0101FIR	Interlock Relay	When combining an HRV with a Furnace or Fan Coil
KVATM010120C	20 Minute Push Button Timer	Used with all HRVs when 20 minute manual operation is required
KVATM010160M	60 Minute Timer	Used with all HRVs, time is adjustable between 10 and 60 minutes
KVAAC0101HOD	Exterior Intake and Exhaust Hood	2 Required, 1 for intake air and 1 for exhaust air on all models except VA3B
KVAAC0101EXH	Exterior Exhaust Hood	1 Required on VA3B models to prevent back flow along with 1 KVAAC0101HOD for intake
KVAAC0101KIT	Start up Balancing Kit	Start up Balancing Kit, includes (2) 6 in. Flow Meter Collars & Magnehelic Gage
KVAAC01016FM	6 in. Flow Meter Collar	At start up, when 6 in. duct work is connected to HRV
KVAAC01017FM	7 in. Flow Meter Collar	At start up, when 7 in. duct work is connected to HRV
KVAAC01018FM	8 in. Flow Meter Collar	At start up, when 8 in. duct work is connected to HRV
KVAFL0101112	Internal Metal Filter	Used on VA3B015 Size Unit, 11-1/2 in. x 12-3/4 in., 1 per unit
KVAFL0101812	Internal Metal Filter	Used on VA3B015 Size Unit, 8-7/8 in. x 12-3/4 in., 1 per unit
KVAFL0101116	Internal Metal Filter	Used on VA3B020 Size Unit, 11-7/8 in. x 16-5/8 in., 1 per unit
KVAFL0101916	Internal Metal Filter	Used on VA3B020 Size Unit, 9 in. x 16-5/8 in., 1 per unit
KVAFL0101123	Internal Metal Filter	Used on VC5B015 Size Unit, 12-15/16 in. x 13-1/2 in., 1 per unit
KVAFL0101145	Internal Metal Filter	Used on VC5B020 VC5B027 Size Units, 14-3/8 in. x 15-1/2 in., 1 per unit
KVAFL0101713	Internal Metal Filter	Used on VB5B015 Size Unit, 7-13/16 in. x 13-1/2 in., 2 per unit
KVAFL0101810	Internal Metal Filter	Used on VC5B020 VC5B027 Size Units, 8-1/8 in. x 10-3/4 in., 1 per unit

Control features

Basic Control: Allows the user to manually set fan speed to low or high as required to maximize comfort.

Standard Control: Offers automatic dehumidistat control and the option to select continuous or intermittent fan operation. Setting the wall control to low will activate the continuous mode.

Automatic Control: In addition to the features found with standard control, this package offers a recirculation mode. These controls may only be used to operate stand-alone units with the defrost option which enables the recirculation feature.

CONTROL DESCRIPTION	FAN SPEED CONTROL	DEHUMIDISTAT CONTROL	CONTINUOUS MODE*	INTERMITTENT MODE*	CIRCULATION MODE†
Basic	Yes	No	Yes	No	No
Standard	Yes	Yes	Yes	Yes	No
Automatic‡	Yes	Yes	Yes	Yes	Yes

* Air exchange with outside.

† No air exchange with outside.

‡ Use only on units with defrost.

Control description and usage

Fan Speed Control — Enables user to modulate fan speed from low to high air exchange with outside.

Dehumidistat Control — Allows the user to select the relative humidity level at which the unit would change fan speed for dehumidification in the winter months.

Continuous Mode — If the relative humidity inside the building is lower than selected, air exchange occurs with the outside at low speed. If the relative humidity inside the house is higher than selected, air exchange occurs with the outside at high speed. Ensures continuous air exchange for constant air quality.

Intermittent Mode — If the relative humidity inside the building is lower than selected, no air exchange occurs and the system turns off. If the relative humidity inside the house is higher than selected, air exchange occurs with the outside at high speed. Ensures minimum air exchange level when the building is unoccupied to minimize operating costs.

Circulation Mode — If the relative humidity inside the building is lower than selected, the ambient air would be circulated and filtered at high speed. If the relative humidity inside the house is higher than selected, air exchange would occur with the outside at high speed. Ensures continuous movement and filtration of air for maximum comfort. Available with automatic control only.

Automatic defrost cycle features

All models offer a non-electric defrost cycle feature which prevents frost and ice buildup within the heat recovery core. When the outside air temperature falls below 23°F (−5°C) it is electronically sensed and the dampers close the outside air ports. This allows warm indoor air to recirculate within the heat recovery core. The frequency of this cycle increases as the outside air temperature decreases.

MODEL	23°F TO 5°F (−5°C TO −15°C)		5°F TO −22°F (−15°C TO −30°C)		BELOW −22°F (−30°C)	
	DEFROST*	EXCHANGE†	DEFROST*	EXCHANGE†	DEFROST*	EXCHANGE†
VA3BAB	5 Minutes	60 Minutes	5 Minutes	35 Minutes	5 Minutes	20 Minutes
VB5BAB	5 Minutes	60 Minutes	5 Minutes	30 Minutes	5 Minutes	20 Minutes
VC5BAB	6 Minutes	60 Minutes	6 Minutes	35 Minutes	6 Minutes	20 Minutes

* Length of defrost time

† Time between defrost when within specified temperature range

Dimensions

NOTES:

1. FRESH AIR FROM OUTSIDE TO HRV
2. FRESH AIR FROM HRV TO HOUSE
3. STALE AIR FROM HOUSE TO HRV
4. STALE AIR FROM HRV TO OUTSIDE

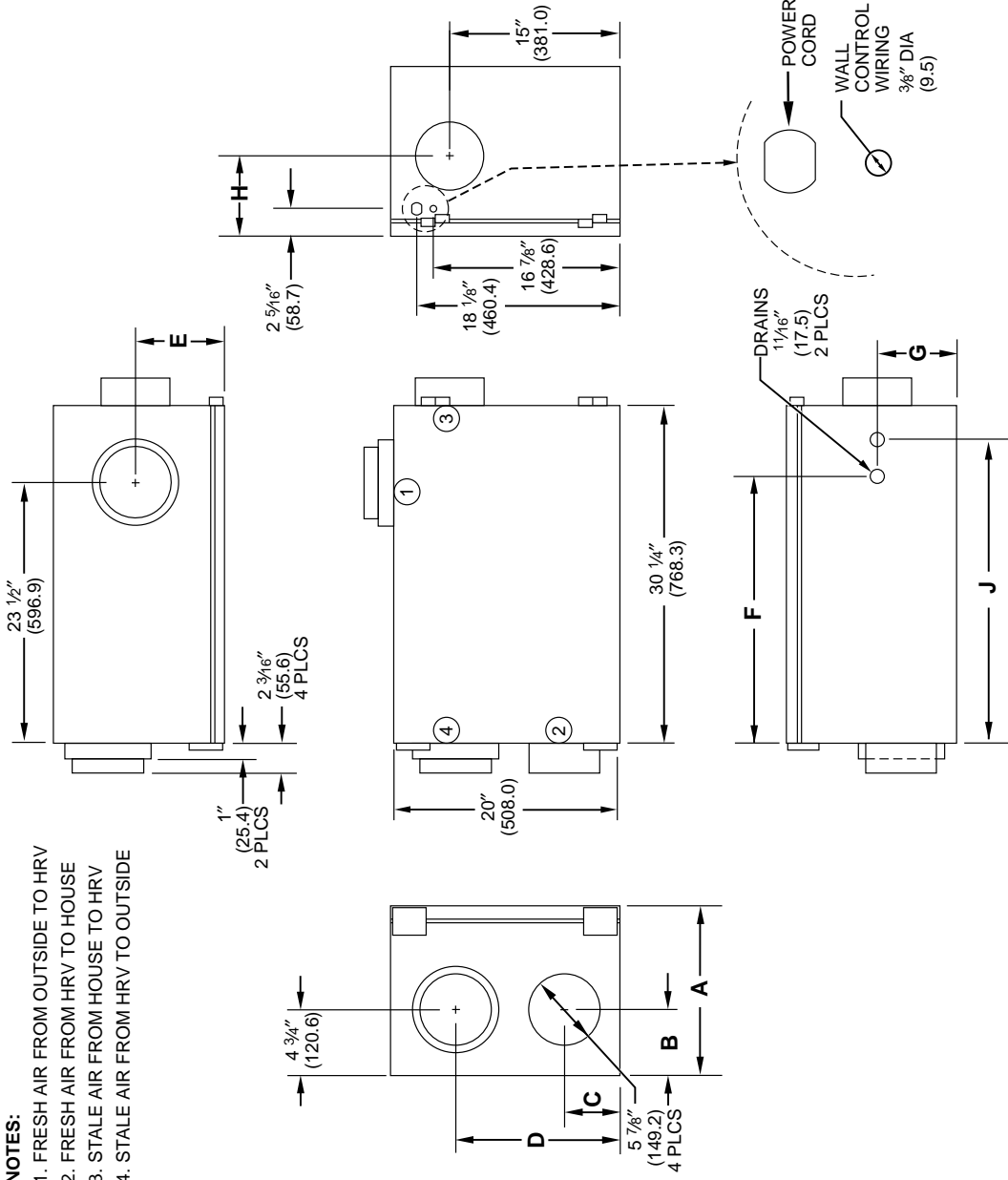

A98002

MODEL NO.	A		B		C		D		E		F		G		H		J	
	in.	mm	in.	mm	in.	mm	in.	mm	in.	mm	in.	mm	in.	mm	in.	mm	in.	mm
VA3BAB015	15-3/16	385.8	4-3/4	120.6	5-1/8	130.2	14-3/4	374.6	7-5/8	193.6	20-3/8	517.5	7-5/16	185.7	7-3/4	196.8	27	685.8
VA3BAB020	18-7/8	479.4	13-1/2	342.9	5-7/8	149.2	14	355.6	10	254.0	15-13/16	401.6	9-5/16	236.6	8-13/16	223.8	27	685.8

Dimensions continued

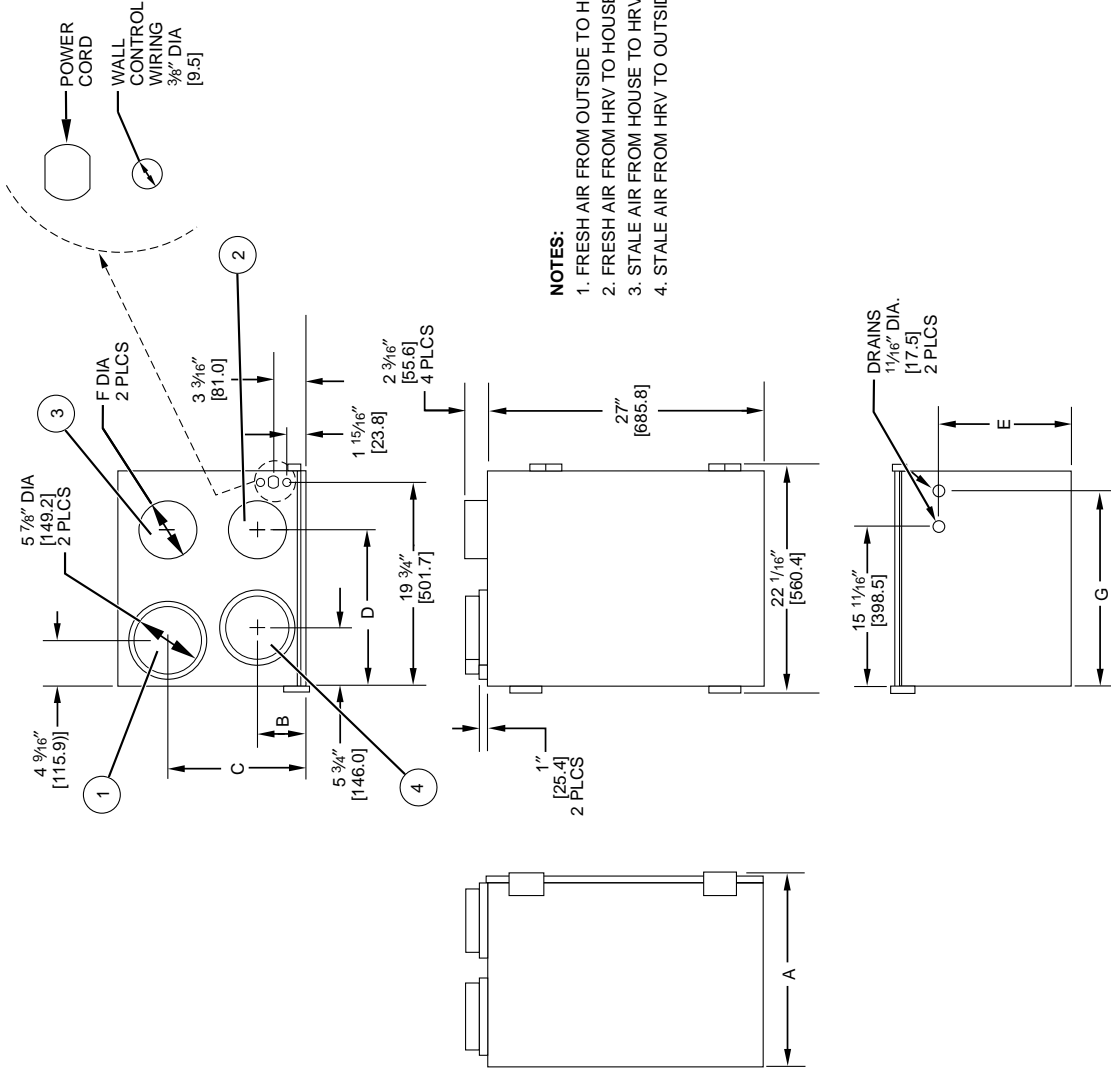

- NOTES:**
1. FRESH AIR FROM OUTSIDE TO HRV
 2. FRESH AIR FROM HRV TO HOUSE
 3. STALE AIR FROM HOUSE TO HRV
 4. STALE AIR FROM HRV TO OUTSIDE

A98003

MODEL NO.	A		B		C		D		E		F		G	
	in.	mm	in.	mm	in.	mm	in.	mm	in.	mm	in.	mm	in.	mm
VB5BAB015	18-1/2	469.9	4-11/16	119.1	13-5/16	388.2	15-7/16	392.1	13-9/16	344.5	5-7/8	149.2	19-15/16	506.2
VB5BAB020	24-1/2	622.2	8-3/16	208.0	19-5/16	490.6	14-9/16	369.9	16-15/16	430.2	6-7/8	174.6	19-15/16	506.2

Dimensions continued

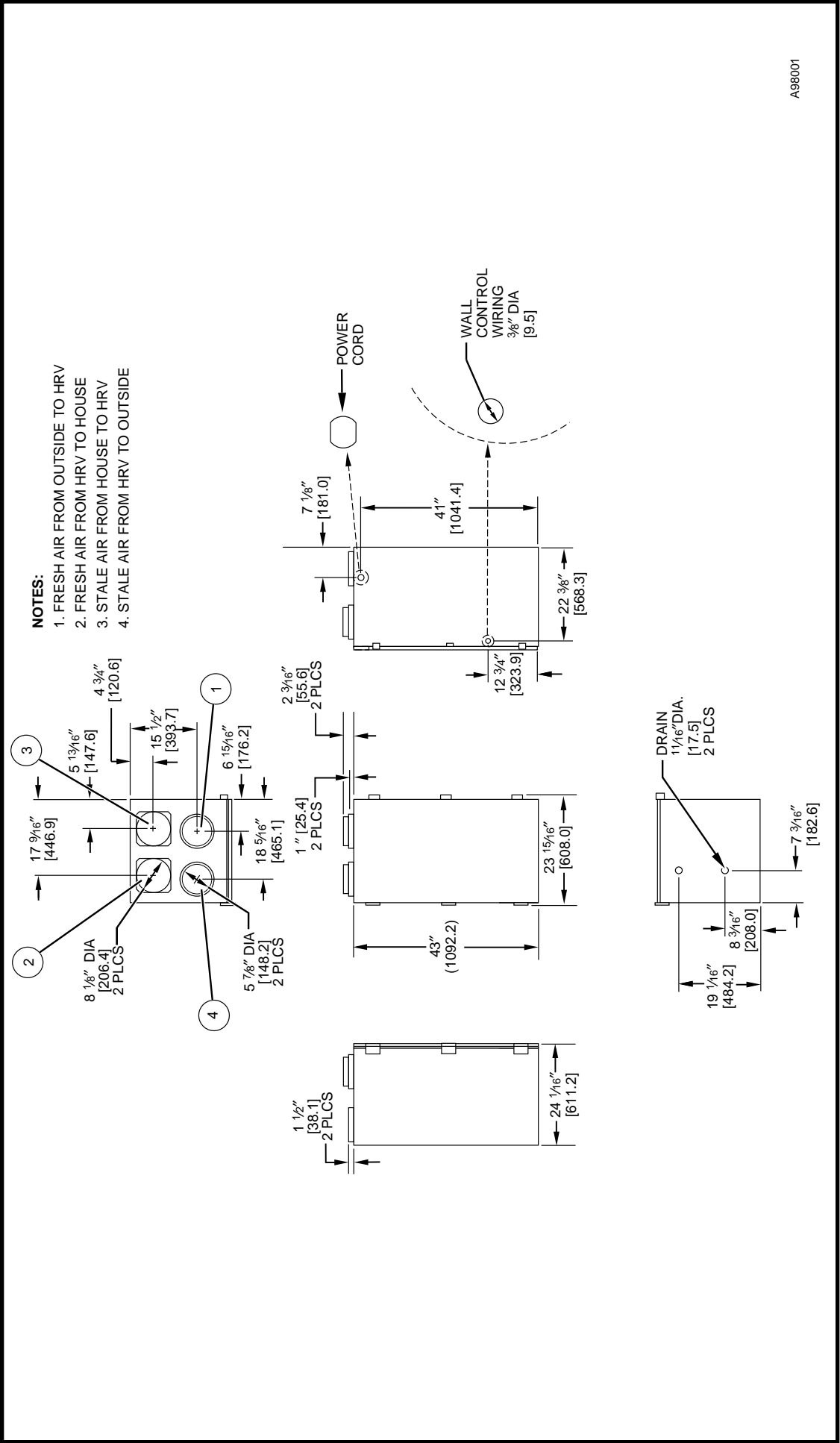

VC5BAB020 or VC5BAB027

A98001

Physical data

MODEL DESCRIPTION	CONVENTIONAL		COMPACT		HIGH EFFICIENCY		
Model No.	VA3BAB015	VA3BAB020	VB5BAB015	VB5BAB020	VC5BAB015	VC5BAB020	VC5BAB027
Capacity — CFM @ 0.5–0.3 ESP (in. wc)	130–168	191–210	106–150	177–217	123–141	189–209	300–334
Port Locations	Top and Sides	Top and Sides	Top	Top	Top	Top	Top
Core Type	Polypropylene Cross Flow	Polypropylene Cross Flow	Polypropylene Cross Flow	Polypropylene Cross Flow	Polypropylene Cross Flow	Polypropylene Counterflow	Polypropylene Counterflow
Weight — lb (kg)	60 (27)	80 (36.6)	60 (27)	80 (36.3)	80 (36.3)	120 (54.5)	120 (54.5)
Shipping Weight — lb (kg)	67 (30.4)	85 (38.5)	75 (34)	89 (40.4)	89 (40.4)	143 (64.9)	143 (64.9)
Shipping Dimensions (in.)							
Height	21.00	21.00	31.5	31.5	31.5	47.5	47.5
Width	35.5	35.5	23.25	23.25	23.25	26.0	26.0
Depth	19.75	19.75	26.00	26.00	26.00	26.0	26.0

Performance data

MODEL DESCRIPTION	CONVENTIONAL		COMPACT		HIGH EFFICIENCY		
Model No.	VA3BAB015	VA3BAB020	VB5BAB015	VB5BAB020	VC5BAB015	VC5BAB020	VC5BAB027
Capacity — CFM @ 0.5–0.3ESP (in. wc)	130–168	191–210	106–150	177–211	123–141	189–209	300–334
Efficiency (Sensible) — percent							
95°F (35°C)	27	22	19	23	27	23	22
32°F (0°C)	76	68	69	77	81	84	80
–13°F (–25°C)	56	61	60	67	69	72	74
Efficiency (Latent) — percent @ all temperatures	0	0	0	0	0	0	0
Heat Core Exchange Area — cu ft (cu m)	120	160	90	144	144	210	210
	11.2	14.9	8.4	13.3	13.3	19.5	19.5

Electrical data

	CONVENTIONAL		COMPACT		HIGH EFFICIENCY		
Model	VA3BAB015	VA3BAB020	VB5BAB015	VB5BAB020	VC5BAB015	VC5BAB020	VC5BAB027
Voltage	120	120	120	120	120	120	120
Max Power — watts	105	218	115	195	115	250	500
Max Amps	1.2	2.0	1.2	1.8	1.2	2.2	5.4

Methods to size HRV's

METHOD 1

1. Calculate cu ft of occupied space.
2. Multiply by recommended air changes per hr (AC/h).
3. Divide by 60 minutes per hr to convert to CFM.

EXAMPLE: 2000 sq ft with 8 ft ceiling
0.35 air changes per hr (AC/h)

$$(2000 \text{ sq ft} \times 8 \text{ ft ceiling} \times 0.35 \text{ AC/h}) / 60 \text{ min/h} = 93.3 \text{ CFM}$$

METHOD 2

1. Multiply number of people times 15 CFM/person.
2. Multiply number of bath rooms 20 CFM/each.
3. Add 25 CFM for kitchen.

EXAMPLE: 2 people
2 baths
1 kitchen

$$(2 \times 15) + (2 \times 20) + 25 = 95 \text{ CFM}$$

Additional heating and cooling load charts

Although the ventilators process the outside air before it enters the home, additional heating and cooling loads need to be considered.

Heating load BTU

Outside Temp °F	Heat Load (Btuh) @ Inside Design Temp 72°F								
	VA3BAB015	VA3BAB020	VB5BAB015	VB5BAB020	VC5BAB015	VC5BAB020	VC5BAB027	VL3AAA015*	VL3AAA020*
-25	7,990	9,290	6,970	7,690	5,500	6,650	9,990	—	—
-20	7,260	8,630	6,470	7,090	5,030	6,070	9,310	—	—
-15	6,570	7,990	5,990	6,520	4,590	5,510	8,650	—	—
-13	6,300	7,730	5,800	6,300	4,410	5,290	8,390	—	—
-10	5,910	7,360	5,520	5,970	4,160	4,970	8,000	—	—
-5	5,280	6,760	5,070	5,440	3,750	4,470	7,380	—	—
0	4,600	6,060	4,550	4,840	3,300	3,910	6,640	—	—
5	4,050	5,510	4,130	4,360	2,940	3,470	6,060	—	—
10	3,540	4,980	3,730	3,900	2,600	3,050	5,500	—	—
15	3,010	4,380	3,290	3,400	2,240	2,600	4,870	3,170	4,730
20	2,570	3,900	2,930	3,000	1,940	2,240	4,350	2,890	4,320
25	2,170	3,440	2,580	2,610	1,670	1,910	3,850	2,610	3,900
30	1,800	2,990	2,240	2,250	1,410	1,600	3,370	2,330	3,490
32	1,640	2,780	2,090	2,080	1,300	1,460	3,140	2,200	3,280
35	1,440	2,530	1,900	1,880	1,160	1,300	2,870	2,030	3,040
40	1,140	2,130	1,600	1,560	940	1,040	2,430	1,760	2,630

* See ERV Product Data for details.

The heating load chart shows the heating loads in Btuh for a range of winter design temperatures for each model of ventilator.

EXAMPLE: The heating design temperature for Milwaukee, WI is -4°F. At -5°F, the additional heating load of the VA3BAB020 is 6760 Btuh. This additional load should be taken into consideration when sizing the heating equipment.

Cooling load BTU

Outside Enthalpy Btu/lb	Cooling Load (Btuh) @ Inside Design Temp 75°F and 50% Relative Humidity								
	VA3BAB015	VA3BAB020	VB5BAB015	VB5BAB020	VC5BAB015	VC5BAB020	VC5BAB027	VL3AAA015*	VL3AAA020*
30	700	1,020	780	990	770	990	1,390	550	800
31	1,170	1,690	1,300	1,650	1,290	1,650	2,310	920	1,330
32	1,640	2,370	1,820	2,310	1,800	2,310	3,240	1,280	1,860
33	2,110	3,050	2,340	2,970	2,310	2,970	4,170	1,650	2,390
34	2,580	3,720	2,860	3,630	2,830	3,630	5,090	2,020	2,920
35	3,050	4,440	3,380	4,290	3,340	4,290	6,020	2,380	3,450
36	3,520	5,080	3,910	4,950	3,860	4,950	6,940	2,750	3,990
37	3,990	5,760	4,430	5,610	4,370	5,610	7,870	3,110	4,520
38	4,460	6,430	4,950	6,270	4,890	6,270	8,790	3,480	5,050
39	4,930	7,110	5,470	6,930	5,400	6,930	9,720	3,850	5,580
40	5,400	7,790	5,990	7,590	5,910	7,590	10,650	4,210	6,110
41	5,870	8,460	6,510	8,250	6,430	8,250	11,570	4,580	6,640
42	6,340	9,140	7,030	8,910	6,940	8,910	12,500	4,950	7,170

* See ERV Product Data for details.

The cooling load chart shows loads in Btuh as well. To use the cooling load chart, first find the design enthalpy from a psychrometric chart using the design dry bulb and wet bulb temperatures. (See psychrometric chart on p. 11.) The cooling load can then be found for a range of enthalpies for each ventilator.

EXAMPLE: The cooling design dry bulb temperature for Milwaukee, WI is 87°F and the average wet bulb at that temperature is 73°F. On the psychrometric chart the enthalpy is about 37.7 Btu/lb of dry air which will round up to 38 Btu/lb of dry air. In the left column, at 38 Btu/lb the VA3BAB020 would have an additional cooling load of 6430 Btuh. This additional load should be taken into account when sizing the air cooling equipment.

Psychrometric chart

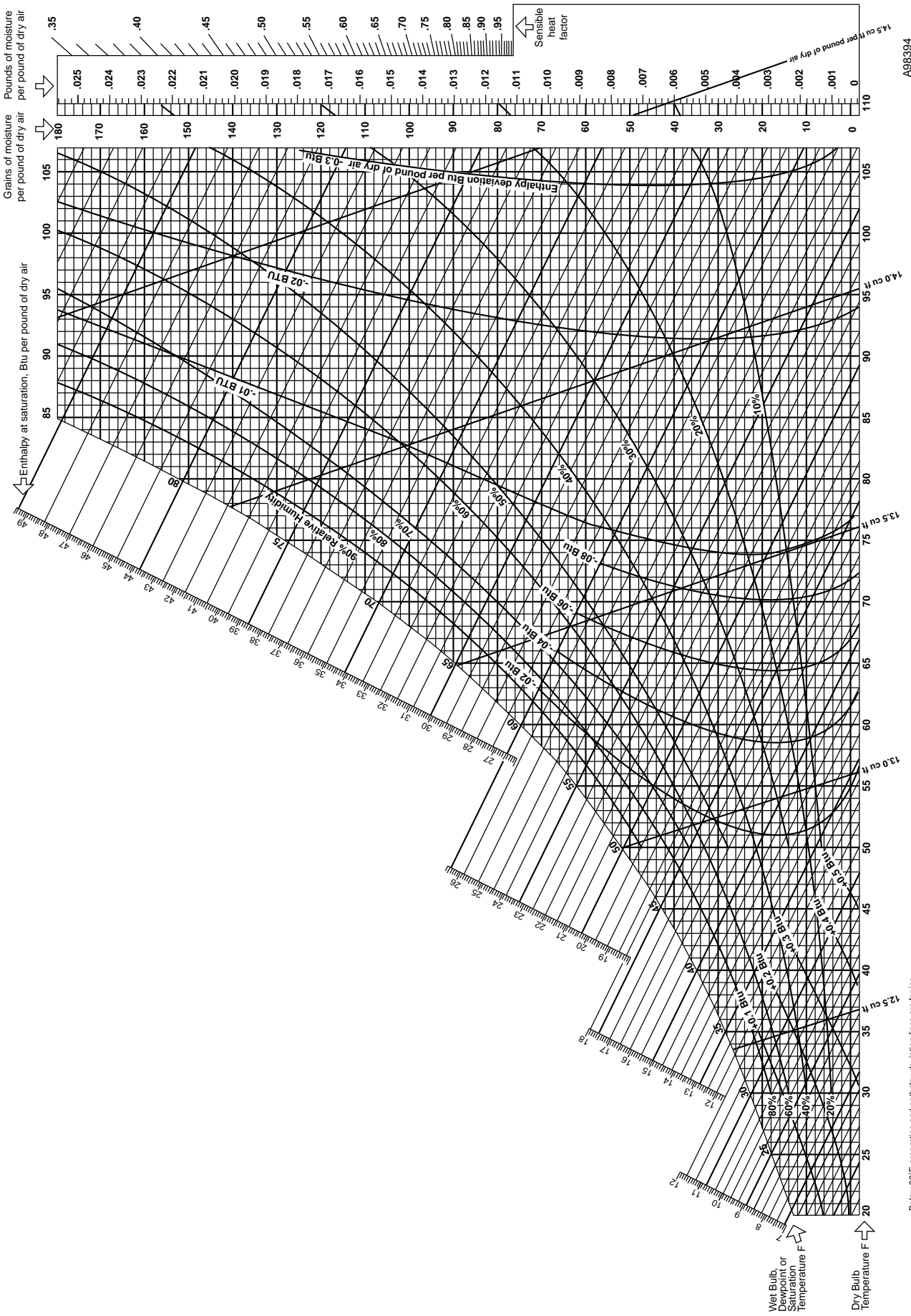

Below 32 F, properties and enthalpy deviation lines are for ice.

A98394

HRV installed with forced air system

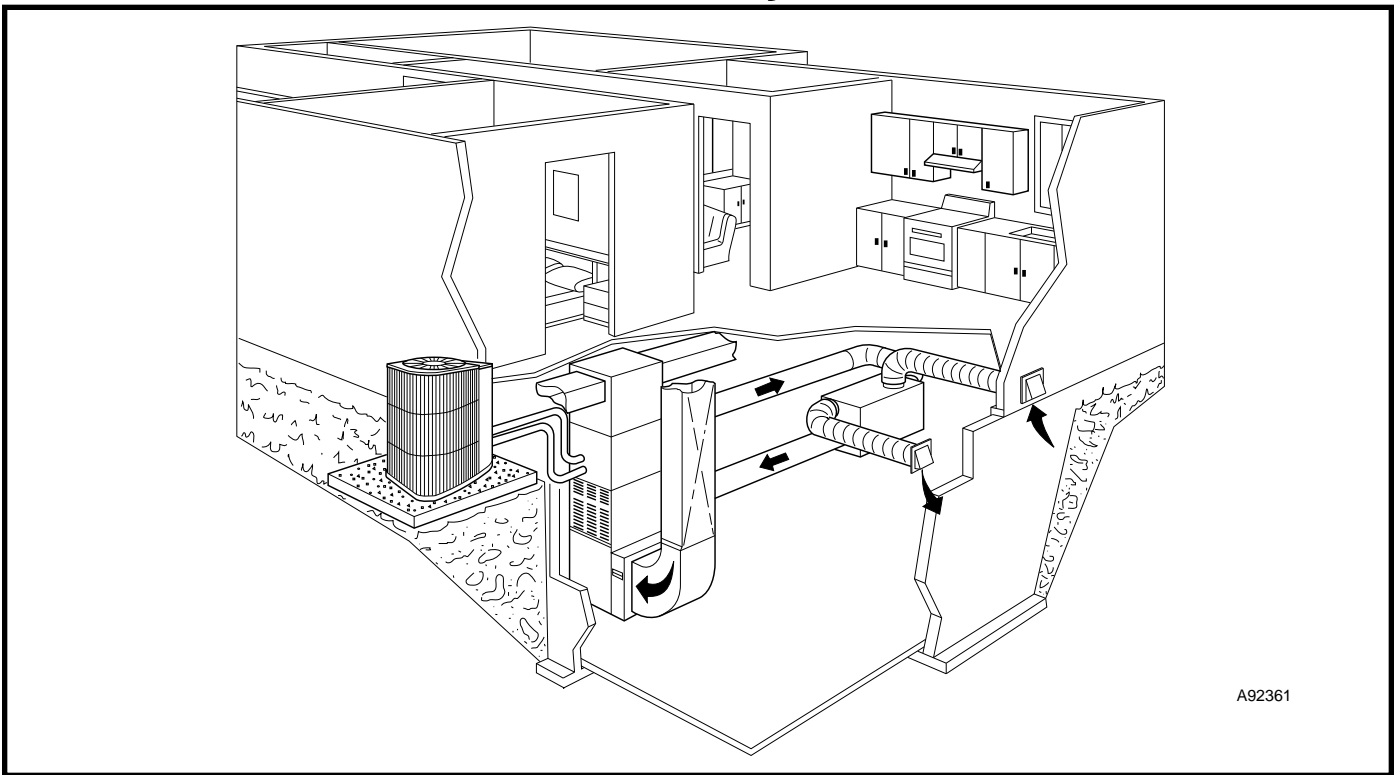

HRV installed with independent air distribution

