

High Altitude Gas Conversion Kit Accessory LP (Liquid Propane) Gas Heating/Electric Cooling 3 to 15 Ton Small Rooftop Units

Installation Instructions

PART NO. CRLPELEV001A00-CRLPELEV004A00,
CRLPELEV007A00-CRLPELEV009A00

CONTENTS

	Page
SAFETY CONSIDERATIONS	1
PACKAGE CONTENTS	2
LP (Liquid Propane) Kit	2
High Altitude Kit (Natural Gas)	2
GENERAL	2
LP CONVERSION KIT INSTALLATION	3
Step 1 — Remove Burner Section from Base Unit .	3
Step 2 — Modify Burner/Valve Assembly	4
Step 3 — Re-install Burner Assembly	6
Step 4 — Install New Limit Switch	7
Step 5 — Check Unit Operation and Make Necessary Adjustments	7
HIGH ALTITUDE CONVERSION KIT INSTALLATION	7
Step 1 — Remove Burner Section from Base Unit .	7
Step 2 — Modify Burner/Valve Assembly	7
Step 3 — Re-install Burner Assembly	8
Step 4 — Check Unit Operation and Make Necessary Adjustments	9

SAFETY CONSIDERATIONS

Installation and servicing of air-conditioning equipment can be hazardous due to system pressure and electrical components. Only trained and qualified service personnel should install, repair, or service air-conditioning equipment.

Untrained personnel can perform basic maintenance functions of cleaning coils and filters and replacing filters. All other operations should be performed by trained service personnel. When working on air-conditioning equipment, observe precautions in the literature, tags and labels attached to the unit, and other safety precautions that may apply.

Follow all safety codes, including ANSI (American National Standards Institute) Z223.1. Wear safety glasses and work gloves. Use quenching cloth for unbrazing operations. Have fire extinguisher available for all brazing operations.

It is important to recognize safety information. This is the safety-alert symbol . When you see this symbol on the unit and in instructions or manuals, be alert to the potential for personal injury.

Understand the signal words DANGER, WARNING, CAUTION, and NOTE. These words are used with the safety-alert symbol. DANGER identifies the most serious hazards which **will** result in

severe personal injury or death. WARNING signifies hazards which **could** result in personal injury or death. CAUTION is used to identify unsafe practices, which **may** result in minor personal injury or product and property damage. NOTE is used to highlight suggestions which **will** result in enhanced installation, reliability, or operation.

IMPORTANT: Read these instructions completely before attempting to install this accessory.

IMPORTANT: The accessories described in this installation instructions manual are suitable for use on the models listed below. **DO NOT ATTEMPT TO INSTALL ON MODELS AND SIZES NOT INCLUDED IN THESE TABLES.**

Table 1 — Unit Usage

CARRIER MODELS		
Check positions 7-8 on unit dataplate for unit size.		
MODEL	UNIT SIZES	NOMINAL TONS
48FC	04-16	3-15
48GC	04-14	3-12.5
48JC	04-06	3-5
48TC	08-16	7.5-15
48HC	07-14	6 -12.5
48KC	04-06	3-5
48LC	04-12	3-10
BRYANT MODELS		
Check positions 6-7 on unit dataplate for unit size.		
MODEL	UNIT SIZES	NOMINAL TONS
582K	04-16	3-15
581K	04-14	3-12.5
580J	08-16	7.5-15
581J	07-14	6-12.5
582J	04-06	3-5
ICP MODELS		
Check positions 6-7 on unit dataplate for unit size.		
MODEL	UNIT SIZES	NOMINAL TONS
RGV	036-180	3-15
RGW	036-150	3-12.5
RGS	089-180	7.5-15
RGH	072-150	6-12.5
RGX	036-060	3-5

NOTE: Not all unit sizes may be available at this time.

PACKAGE CONTENTS

LP (Liquid Propane) Kit

ACCESSORY PART NO.	ORIFICES		
	SIZE	QTY	PART NUMBER
CRLPELEV003A00 (LP Only)	46	5	LH32RF080
	47	5	LH32RF079
	48	5	LH32RF076
	49	5	LH32RF073
	50	5	LH32RF070
CRLPELEV004A00 (LP Only)	51	5	LH32RF067
	52	5	LH32RF065
	53	5	LH32RF060
	54	5	LH32RF055
	55	5	LH32RF052
CRLPELEV009A00 (LP Only)	51	10	LH32RF067
	52	10	LH32RF065
	53	10	LH32RF060
	54	10	LH32RF055
	55	10	LH32RF052

COMMON CONTENTS	QTY	PART NUMBER
Elbow, 1/8-in. NPT X 90°	1	CA05RA001
Elbow, Street 1/8-in. NPT X 90°	1	CA15RA001
Nipple, 1/8-in. Pipe X 3/4-in.	1	CA01CA001
Nipple, 1/8-in. Pipe X 1-1/2-in.	1	CA01CA006
Nipple, 1/8-in. Pipe X 3-1/2-in.	1	CA01CA020
Switch, LP Pressure	1	HK02LB008
Wire, Brown	1	99WG7373XC200918
Springs, LP Conversion	2	EF39ZW023
Label, LP Conversion Kit Rating Plate	1	48TM502595
Label, LP Responsibility	1	48TM501014
Label, High-alt. Responsibility	1	48TM501015

Package Contents CRLPELEV003 and 004A00 Only

CRLPELEV003, 004A00 ONLY	QTY	PART NUMBER
Label, Gas Valve LP Conv	1	48TM501013
Label, Unit Warning (LP)	1	48TM501012

Package Contents CRLPELEV009A00 Only

CRLPELEV009A00 ONLY	QTY	PART NUMBER
Label, Gas Valve LP Conv	1	48TM504835
Label, Unit Warning (LP)	1	48TM504836
Switch, Temperature Actuated	1	HH18HA147

High Altitude Kit (Natural Gas)

ACCESSORY PART NO.	ORIFICES		
	SIZE	QTY	PART NUMBER
CRLPELEV001A00 (Natural Gas Only)	31	5	LH32RF120
	32	5	LH32RF116
	33	5	LH32RF113
	35	5	LH32RF110
	36	5	LH32RF105
CRLPELEV002A00 (Natural Gas Only)	37	5	LH32RF104
	38	5	LH32RF102
	39	5	LH32RF103
	44	5	LH32RF086
	45	5	LH32RF082
CRLPELEV007A00 (Natural Gas Only)	36	10	LH32RF105
	37	10	LH32RF104
	38	10	LH32RF102
	39	10	LH32RF103
CRLPELEV008A00 (Natural Gas Only)	40	10	LH32RF098
	41	10	LH32RF096
	42	10	LH32RF094
	43	10	LH32RF089

COMMON CONTENTS	QTY	PART NUMBER
Label, High-alt. Responsibility	1	48TM501015
Label, NG Conversion Kit Rating Plate	1	48TM502594

GENERAL

These models are shipped from the factory equipped to operate with natural gas at elevations up to 2000 ft (610 m). The units must be modified if installed at elevations above 2000 ft (610 m), or if operated with liquid propane.

For installations in Canada, the input rating must be derated by 10% for altitudes of 2000 ft (610 m) to 4500 ft (1372 m) above sea level.

Check that your unit model number agrees with Table 1.

Seven different gas conversion kits are available, as shown in Package Contents table. Each kit contains a particular range of orifice sizes plus other hardware and labels necessary for converting the unit. Refer to Tables 2-5 to determine the recommended orifice size based on the nominal heat size, fuel type, and elevation. Knowing this orifice size, it is possible to select the proper Kit Accessory Part Number from Package Contents table.

IMPORTANT: If Low NOx units are converted to LP gas, the Low NOx baffle must be removed. (See Fig. 1.) The converted unit will no longer be classified as a Low NOx unit. For installation simplicity, it is suggested that the LP Conversion Kit be used with standard units only.

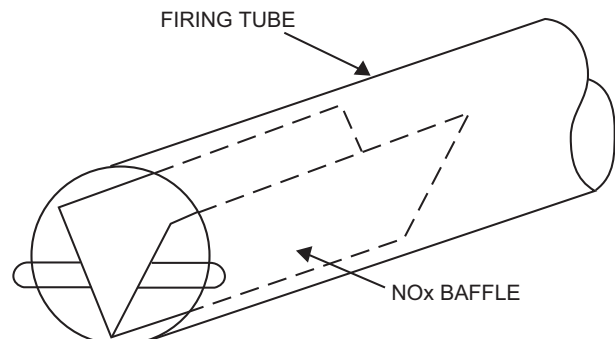

Fig. 1 — Low NOx Baffle Location

⚠ WARNING

FIRE, EXPLOSION, CARBON MONOXIDE POISONING, PROPERTY DAMAGE HAZARD

Failure to follow this warning could result in personal injury, death or property damage.

This conversion kit shall be installed by a qualified service agency in accordance with the manufacturer's instructions and all applicable codes and requirements of the authority having jurisdiction. The qualified service agency is responsible for the proper installation of this kit. The installation is not proper and complete until the operation of the converted furnace is checked as specified in the manufacturer's instructions supplied in the kit.

⚠ AVERTISSEMENT

FEU, EXPLOSION, EMPOISONNEMENT PAR CARBON DE MONOXYDE, RISQUE DE DOMMAGE ALAPROPRIÉTÉ

La négligence de suivre l'avis suivant, peut causer des blessures personnelles, la mort ou du dommage à la propriété.

Cette trousse de conversion doit être installée par un Entrepreneur qualifié, selon les instructions du fabricant et doit se conformer à toutes les exigences et tout les codes pertinents de l'autorité compétente. L'Entrepreneur qualifié est responsable, et doit s'assurer de bien suivre les instructions dans cet avis. L'installation sera considérée conforme et rencontrant les spécifications et instructions du fabricant qui sont inclus dans la trousse, seulement après vérification de l'opération de la fournaise convertie.

⚠ WARNING

EXPLOSION, PERSONAL INJURY HAZARD

Failure to follow this warning could result in personal injury or death.

Two-Stage Gas Valve - Unit is designed to operate at specific values (see Tables 6-8 of manifold pressure with propane gas).

Single-Stage Gas Valve - Unit is designed to operate at a 10 in. wg of manifold pressure with propane gas.

⚠ WARNING

FIRE, EXPLOSION, ELECTRICAL HAZARD

Failure to follow this warning could result in personal injury, death or property damage.

Gas supply **MUST** be shut off before disconnecting electrical power and proceeding with conversion.

⚠ WARNING

ELECTRICAL SHOCK HAZARD

Failure to follow this warning could result in personal injury or death.

Before installing or servicing system, always turn off main power to system. There may be more than one disconnect switch. Tag disconnect switch with suitable warning label.

⚠ WARNING

FIRE HAZARD

Failure to follow this warning could result in severe personal injury and/or property damage.

Inlet pressure tap set screw must be tightened and 1/8 in. NPT pipe plug must be installed to prevent gas leaks.

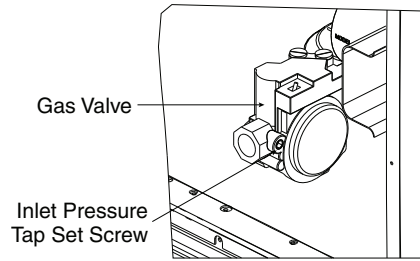

⚠ WARNING

FIRE HAZARD

Failure to follow this warning could result in severe personal injury and/or property damage.

Manifold pressure tap set screw must be tightened and 1/8 in. NPT pipe plug must be installed to prevent gas leaks.

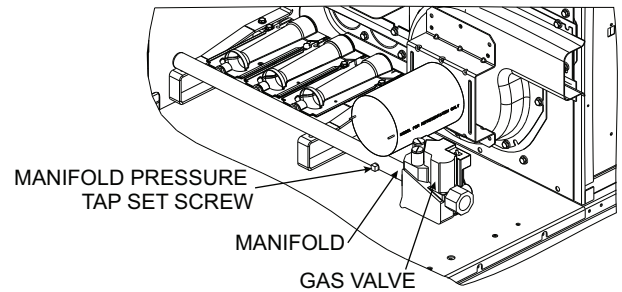

LP CONVERSION KIT INSTALLATION

IMPORTANT: Before starting installation of this accessory, check your unit's dataplate for model and size and compare to the Unit Usage table on page 1. If your unit's size designation exceeds the largest size listed for your model, STOP. This accessory is not for use on your unit. Consult with your sales office for the correct accessory part number for use on your unit.

Step 1 — Remove Burner Section from Base Unit

1. Shut off main gas supply to unit.
2. Shut off power to unit and install lockout tag.
3. Remove burner access panel. (See Fig. 2.)
4. Slide out burner section side panel.
5. Disconnect gas piping at unit gas valve.
6. Remove wires connected to gas valve. Mark each wire.
7. Remove igniter and sensor wires. Mark each wire.
8. For units with burner sections as shown in Fig. 3, remove the 2 screws that attach the burner rack to the vestibule plate. For units with burner sections as shown in Fig. 4 and 5 remove the 4 screws that hold the manifold to the sheet metal brackets.

9. Remove the gas valve bracket.
10. Slide the burner rack or manifold out of the unit.
11. For small chassis units only-inspect the inlet of the heat exchanger tubes for presence of V-shaped NOx baffles. (See Fig. 1.) If baffles are present, they must be removed prior to converting unit for propane gas. Using needle nose pliers, remove NOx baffles. Squeeze sides of the baffle, if necessary, to remove from the heat exchanger tubes.

IMPORTANT: If this unit will be converted back to natural gas at a later time, these baffles should be retained for reuse. Otherwise the baffles may be discarded.

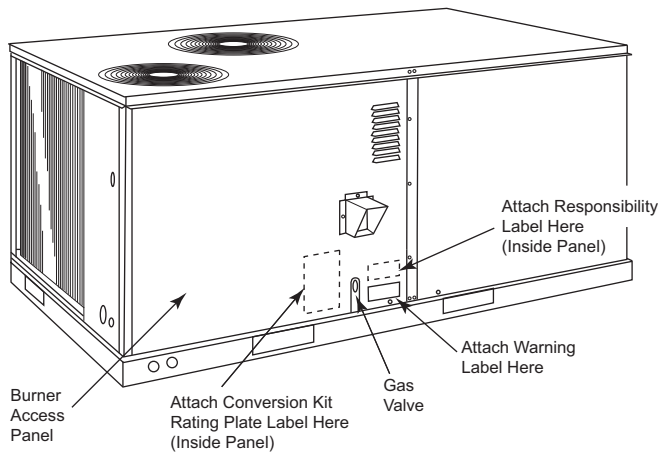

Fig. 2 — Typical Base Unit

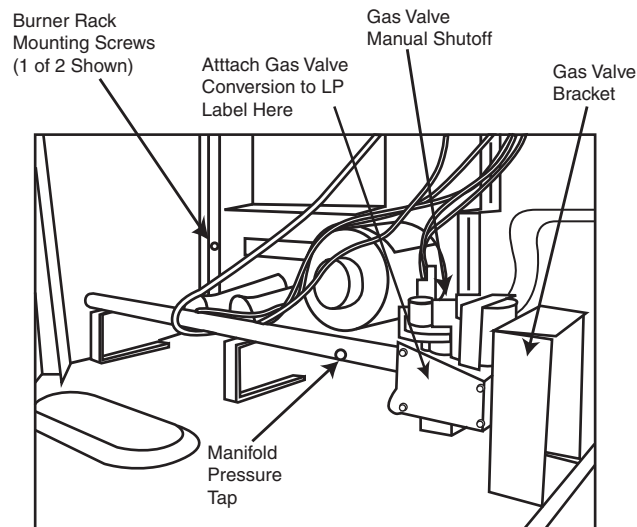

Fig. 3 — Gas Section Details (Small Chassis Shown)

Step 2 — Modify Burner/Valve Assembly

1. Separate burners from frame by removing screws.
2. Remove existing gas orifices. Install the new orifices from the gas conversion kit, making sure they match the recommended size from Tables 2-5.

IMPORTANT: Never use Teflon tape to seal gas orifice threads because peeling tape can plug the orifice.

3. Remount burners to support frame.

IMPORTANT: The burners should be positioned in the same order as shipped from the factory. The crossover flame region of the outermost burners are pinched off to prevent excessive gas flow from the sides of the burner assembly. If the pinched crossovers are installed between two burners, the flame will not ignite properly.

4. Remove the plug on the inlet end of the gas valve using a 3/16-in. hex wrench. (See Fig. 4 and 7 for units using White-Rodgers 36G gas valve and Fig. 5 and 6 for units using White-Rodgers 36H gas valve).

5. Units with 36G and 36H valves:
 - a.

- a. **For units with 36G valve**, install the 1/8-in. x 1-1/2-in. nipple where the plug was removed. (See Fig. 4.) Use pipe thread dope or tape (field-supplied, must be certified for use with propane gas) for all joints, making sure not to get any excess in the pipe or valve. Next, install the 1/8-in. x 90 degree elbow, then 1/8-in. x 3/4-in. nipple, followed by the LP Pressure Switch as shown in Fig. 4.

For Single-Stage Gas Valves, connect supplied brown jumper wire from the “NO” (Normally Open) terminal on the pressure switch to the terminal where the gray wire was attached.

NOTE: Terminals are not marked on Gas Valve.

For Two-Stage Gas Valves, connect the supplied brown jumper wire from the “NO” terminal on the pressure switch to terminal “M” on the gas valve.

- b. **For units with 36H valve**, install the 1/8-in. x 3/4-in. nipple where the plug was removed. (See Fig. 5.) Use pipe thread dope or tape (field supplied, must be certified for use with propane gas) for all joints, making sure not to get any excess in the pipe or valve. Next, install the gas valve bracket over nipple, then the 1/8-in. x 90 degree elbow, then 1/8-in. x 3 1/2-in. nipple, then 1/8-in. x 90 degree street elbow, followed by the LP Pressure Switch as shown in Fig. 5. Connect the supplied brown jumper wire from the “NO” terminal on the pressure switch to terminal “MP” on the gas valve.

6. Remove regulator cover screw(s) from gas regulator(s). (See Fig. 6 or 7.) Save regulator cover screws.
7. Using a screwdriver, remove plastic adjust screw(s) from both regulators. (See Fig. 6 or 7.) Save plastic adjust screws.
8. Remove regulator spring(s) (silver) from gas regulator(s). (See Fig. 6 or 7.) Discard regulator springs.
9. Install propane gas regulator spring(s) (white) shipped with the kit into the gas regulator(s). (See Fig. 6 or 7.)
10. For two-stage gas valves, install plastic adjust screw into the high stage gas regulator, turn clockwise 13.5 turns. (See Fig. 6 or 7.) Then install plastic adjust screw into the low stage gas regulator, turn clockwise 9.5 turns. Replace regulator cover screws. (See Fig. 6 or 7.)

For single-stage gas valves, install plastic adjust screw into the single-stage gas regulator, turn clockwise 13.5 turns. Replace regulator cover screw. (See Fig. 7.)

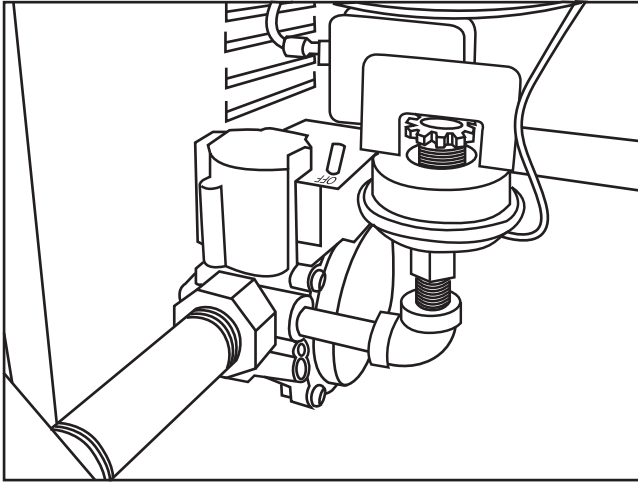

**Fig. 4 — LP Pressure Switch Piping
(36G Gas Valve Shown)**

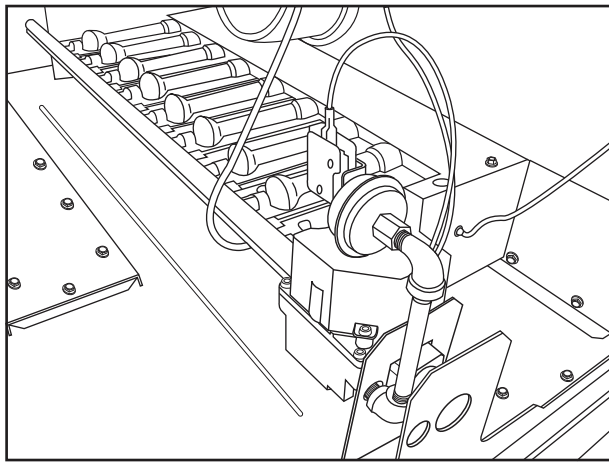

**Fig. 5 — LP Pressure Switch Piping
(36H Gas Valve Shown)**

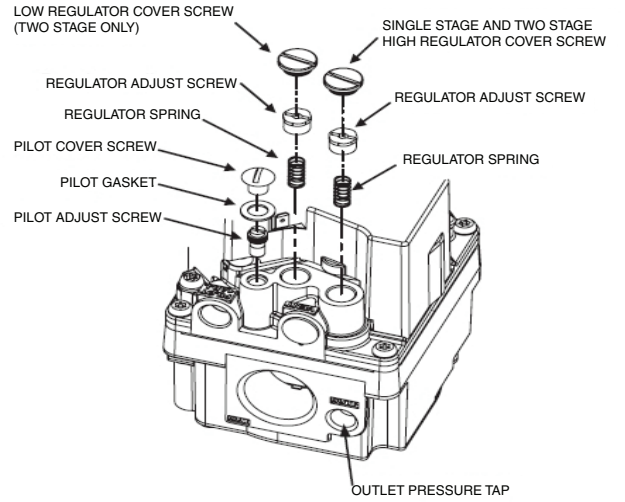

**Fig. 6 — Two-Stage Spring Installation
(36H Gas Valve Shown)**

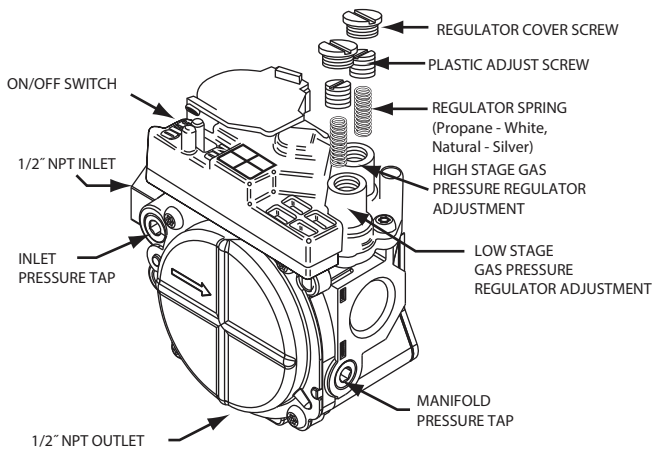

Two-Stage 36G Valve

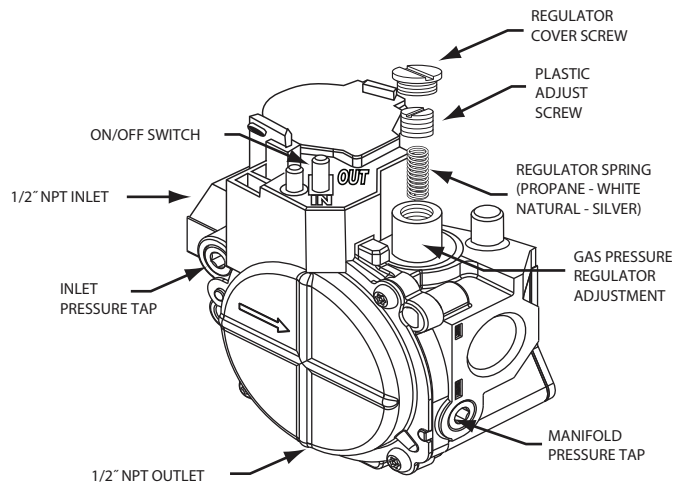

Single-Stage 36G Valve

Fig. 7 — 36G Valve Spring Installation

Step 3 — Re-install Burner Assembly

1. Slide the burner rack into the unit.
2. Attach burner rack or manifold with previously removed screws.
3. Fasten gas valve bracket with 2 screws in base.
4. Reconnect the igniter and sensor wires.
5. Reconnect the wires to the gas valve, except for the grey wire. Connect the grey wire to terminal "C" on the pressure switch.
6. Connect gas piping to the gas valve.
7. Attach LP Conversion Label to gas valve. (See Fig. 3 and 8.)
8. Attach Warning Label to burner access panel. (See Fig. 2 and 9.)
9. Attach completed LP Responsibility Label to inside of burner access panel. (See Fig. 2 and 10.)
10. For High Altitude LP installations, attach LP Conversion Kit Rating Plate Label to inside of burner access panel. (See Fig. 2 and 11.)
11. Leak check all gas connections, including the main service connection, gas valve, gas spuds, and manifold pipe plug. All leaks must be repaired before firing unit.

**THIS UNIT HAS BEEN
CONVERTED TO L.P
GAS WITH FACTORY
SUPPLIED PARTS.**

**MANIFOLD PRESSURE,
6.2"wc**

**THIS UNIT HAS BEEN
CONVERTED TO L.P
GAS WITH FACTORY
SUPPLIED PARTS.**

**MANIFOLD PRESSURE,
10.0"wc**

For 48LCF/T*12 Only

Fig. 8 — Gas Valve Conversion Label (LP Only)

⚠ WARNING

FIRE OR EXPLOSION HAZARD

Failure to follow the safety warnings exactly could result in serious injury, death or property damage.

Never test for gas leaks with an open flame. Use a commercially available soap solution made specifically for the detection of leaks to check all connections. A fire or explosion may result causing property damage, personal injury or loss of life.

⚠ WARNING

THIS UNIT IS DESIGNED TO OPERATE AT 6.2 ± 0.3" OF MANIFOLD PRESSURE WITH L. P. GAS. EXCEEDING THIS PRESSURE WILL CAUSE EXPLOSION OR INJURY.

For 48LCF/T*12 Only

⚠ AVERTISSEMENT

RISQUE D'INCENDIE OU D'EXPLOSION

Si les consignes de sécurité ne sont pas suivies à la lettre, cela peut entraîner la mort, de graves blessures ou des dommages matériels. Ne jamais vérifier la présence de fuites de gaz au moyen d'une flamme nue. Vérifier tous les raccords en utilisant une solution savonneuse commerciale conçue spécialement pour la détection de fuites. Un incendie ou une explosion risque de se produire, ce qui peut entraîner la mort, des blessures ou des dommages matériels.

⚠ WARNING

THIS UNIT IS DESIGNED TO OPERATE AT 10.0 ± 0.3" OF MANIFOLD PRESSURE WITH L. P. GAS. EXCEEDING THIS PRESSURE WILL CAUSE EXPLOSION OR INJURY.

For all others.

Fig. 9 — Unit Warning Label (LP Only)

<p>THIS FURNACE WAS CONVERTED ON _____ TO PROPANE GAS <small>DAY MONTH YEAR</small></p> <p>USING _____ ORIFICE SIZE.</p> <p>BY: _____</p> <p>_____</p> <p>(Name and address of organization making this conversion), which accepts the responsibility that this conversion has been properly made.</p> <p style="text-align: right;">48TM501014 REV-</p>	<p>CÉ GÉNÉRATEUR D'AIR CHAUD A ÉTÉ CONVERTI LE _____ POUR <small>JOUR MOIS ANNEE</small> GAZ DE PÉTROLÉ LIQUÉFIÉ OU PROPANE SI L'ORIFICE EST INDENTIQUE AU TROU D'UN FORÉT N° PAR: _____</p> <p>_____</p> <p>(Nom et adresse de l'organisme qui a effectué la conversion), qui accepte l'entnere responsabilité de la conversion.</p>
-----------------------------------------------------------------------------------------------------------------------------------------------------------------------------------------------------------------------------------------------------------------------------------------------------------------------------------------------------------------------------------------	--------------------------------------------------------------------------------------------------------------------------------------------------------------------------------------------------------------------------------------------------------------------------------------------------------------------------------------------------------------------------------------------------------------------------

Fig. 10 — LP Responsibility Label

The newly installed low gas pressure switch is a safety device used to guard against adverse burner operating characteristics that can result from low gas supply pressure. Switch opens at not less than 7.2 in. wg and closes at not greater than 10.2 in. wg.

This switch also prevents operation when the propane tank level is low which can result in gas with a high concentration of impurities, additives, and residues that have settled to the bottom of the tank. Operation under these conditions can cause harm to the heat exchanger system. This normally open switch closes when gas is supplied to gas valve under normal LP operation pressure of 11.0 to 13.0 in. wg. The closed switch completes the control circuit. Should an interruption or reduction in gas supply occur, the gas pressure at switch drops below low gas pressure switch setting, and switch opens. Any interruption in control circuit (in which low gas pressure switch is wired) quickly closes gas valve and stops gas flow to burners.

CONVERSION KIT RATING PLATE PROPANE GAS	
<p>APPLIES TO MODELS 48TC AND 48HC AND 48LC REFER TO MAIN RATING PLATE FOR SPECIFIC MODEL NUMBER. THIS UNIT HAS BEEN CONVERTED TO OPERATE WITH PROPANE GAS AT ALTITUDES FROM 0 TO 14,000 FEET REFER TO KIT INSTRUCTIONS FOR CONVERSION PROCEDURES.</p>	
<p>CONVERSION KIT PART NUMBERS: CRLPELEV003A00, CRLPELEV004A00, CRLPELEV009A00</p>	
<p>MANIFOLD PRESSURE: SEE INSTALLATION INSTRUCTIONS</p>	
<p>GAS SUPPLY PRESSURE: SEE INSTALLATION INSTRUCTIONS</p>	
<p>REFER TO ALTITUDE COMPENSATION TABLES FOUND IN KIT INSTRUCTIONS FOR REQUIRED INFORMATION TO COMPLETE THIS SECTION.</p>	
<p>INSTALLATION ALTITUDE _____ FT</p>	
<p>ORIFICE SIZE INSTALLED _____</p>	
<p>INPUT RATE AT INSTALLATION ALTITUDE _____ BTU/HR</p>	
<p>FOR INSTALLATIONS IN CANADA, THE INPUT RATING SHOULD BE DERATED BY 10% FOR ALTITUDES FROM 2,000 FT (610 M) TO 4,500 FT (1372 M) ABOVE SEA LEVEL.</p>	
PLAQUE SIGNALÉTIQUE DE TROUSSE DE CONVERSION GAZ PROPANE	
<p>APPLICABLE AUX MODELES 48TC ET 48HC ET 48LC SE RÉFÉRER À LA PLAQUE SIGNALÉTIQUE PRINCIPALE POUR LE NUMÉRO DE MODÈLE SPÉCIFIQUE CET APPAREIL A FAIT L'OBJET D'UNE CONVERSION POUR UN FONCTIONNEMENT AU GAZ PROPANE À DES ALTITUDES SITUÉES ENTRE 0 ET 14,000 PIEDS. SE RÉFÉRER AUX INSTRUCTIONS FOURNIES AVEC LA TROUSSE POUR OBTENIR LES PROCÉDURES DE CONVERSION.</p>	
<p>NUMÉROS DE PIÈCE DES TROUSSES DE CONVERSION: CRLPELEV003A00, CRLPELEV004A00, CRLPELEV009A00</p>	
<p>PRESSION DE COLLECTEUR: VOIR LES INSTRUCTIONS D'INSTALLATION</p>	
<p>PRESSION DE L'ARRIVÉE DE GAZ: VOIR LES INSTRUCTIONS D'INSTALLATION</p>	
<p>SE RÉFÉRER AU TABLEAU DE COMPENSATION D'ALTITUDE FOURNI AVEC LA TROUSSE POUR LES INFORMATIONS NÉCESSAIRES À L'ACHEVEMENT DE CETTE SECTION.</p>	
<p>ALTITUDE D'INSTALLATION _____ M</p>	
<p>TAILLE DE LA BUSE INSTALLÉE _____</p>	
<p>CAPACITÉ D'ENTRÉE À L'ALTITUDE D'INSTALLATION _____ BTU/HR</p>	
<p>POUR LES INSTALLATIONS AUX CANADA, LA CAPACITÉ D'ENTRÉE DOIT ÊTRE DÉPRÉCIEE DE 10% POUR LES ALTITUDES SITUÉES ENTRE 2,000 PIEDS (610 MÈTRES) ET 4,500 PIEDS (1372 MÈTRES) AU DESSUS DU NIVEAU DE LA MER.</p>	
48TM502595	B

Fig. 11 — LP Conversion Kit Rating Plate Label

IMPORTANT: Step 4 is for 48LCF/T*12 propane conversion models ONLY.
For all other models, go to Step 5.

Step 4 — Install New Limit Switch

1. Remove blower access panel.
2. Locate and remove limit switch on blower deck.
3. Replace with new limit switch supplied with CRLPELEV009A00 Propane Conversion Kit.
4. Reconnect wires to new limit switch.
5. Reinstall blower access panel.

Step 5 — Check Unit Operation and Make Necessary Adjustments

NOTE: LP gas supply pressure must not be less than 11 in. wg or greater than 13 in. wg at the unit connection.

1. Remove manifold pressure tap plug from manifold and connect pressure gage or manometer. (See Fig. 3.)
2. Turn on electrical supply.
3. Turn on unit main gas valve.
4. Set room thermostat to call for heat. If unit has two-stage gas valve, verify high-stage heat operation before attempting to adjust manifold pressure.
5. When main burners ignite, check all fittings, manifold, and orifices for leaks.
6. Adjust high-stage pressure according to Tables 6-8 by turning the plastic adjust screw clockwise to increase pressure, counter-clockwise to decrease to pressure.
7. For Two-Stage Gas Valves, set room thermostat to call for low-stage heat. Adjust low-stage pressure according to Tables 6-8.
8. Replace regulator cover screw(s) when finished.
9. With burner access panel removed, observe unit heating operation in both high stage and low stage operation if so equipped. Observe burner flames to see if they are blue in appearance, and that the flames are approximately the same for each burner.
10. Turn off unit, remove pressure manometer and replace the 1/8-in. pipe fitting on the gas manifold. (See Fig. 3.)
11. Re-install burner access panel. (See Fig. 2.)

HIGH ALTITUDE CONVERSION KIT INSTALLATION

⚠ WARNING

FIRE, EXPLOSION, ELECTRICAL HAZARD

Failure to follow this warning could result in personal injury, death or property damage.

Gas supply **MUST** be shut off before disconnecting electrical power and proceeding with conversion.

Step 1 — Remove Burner Section from Base Unit

1. Shut off main gas supply to unit.
2. Shut off power to unit and install lockout tag.
3. Remove burner access panel.
4. Slide out burner section side panel.
5. Disconnect gas piping at unit gas valve.
6. Remove wires connected to gas valve. Mark each wire.
7. Remove igniter and sensor wires. Mark each wire.
8. Remove the 2 screws that attach the burner rack to the vestibule plate.
9. Remove the gas valve bracket.
10. Slide the burner rack out of the unit. (See Fig. 3.)

Step 2 — Modify Burner/Valve Assembly

1. Separate burners from frame by removing screws.
2. Remove existing gas orifices. Install the new orifices from the gas conversion kit, making sure they match the recommended size from Tables 2-5.

IMPORTANT: Never use Teflon* tape to seal gas orifice threads because peeling tape can plug the orifice.

* Teflon is a registered trademark of DuPont.

- Remount burners to support frame.

IMPORTANT: The burners should be positioned in the same order as shipped from the factory. The crossover flame region of the outermost burners are pinched off to prevent excessive gas flow from the sides of the burner assembly. If the pinched crossovers are installed between two burners, the flame will not ignite properly.

Step 3 — Re-install Burner Assembly

- Slide the burner rack into the unit.
- Attach burner rack to vestibule plate with 2 screws.
- Replace gas valve bracket.
- Reconnect the igniter and sensor wires.
- Reconnect wires to gas valve.
- Connect gas piping to the gas valve.
- Attach completed High Altitude Responsibility Label to inside of service access panel. (See Fig. 2 and 12.)
- Attach NG Conversion Kit Rating Plate Label to inside of burner access panel. (See Fig. 2 and 13.)

⚠ WARNING

ELECTRICAL SHOCK HAZARD
 Failure to follow this warning could result in personal injury or death.
 Before installing or servicing system, always turn off main power to system. There may be more than one disconnect switch. Tag disconnect switch with suitable warning label.

⚠ WARNING

FIRE OR EXPLOSION HAZARD
 Failure to follow the safety warnings exactly could result in serious injury, death or property damage.
 Never test for gas leaks with an open flame. Use a commercially available soap solution made specifically for the detection of leaks to check all connections. A fire or explosion may result causing property damage, personal injury or loss of life.

⚠ AVERTISSEMENT

RISQUE D'INCENDIE OU D'EXPLOSION
 Si les consignes de sécurité ne sont pas suivies à la lettre, cela peut entraîner la mort, de graves blessures ou des dommages matériels. Ne jamais vérifier la présence de fuites de gaz au moyen d'une flamme nue. Vérifier tous les raccords en utilisant une solution savonneuse commerciale conçue spécialement pour la détection de fuites. Un incendie ou une explosion risque de se produire, ce qui peut entraîner la mort, des blessures ou des dommages matériels.

- Leak check all gas connections including the main service connection, gas valve, gas spuds, and manifold pipe plug. All leaks must be repaired before firing unit.

<p>THIS FURNACE WAS CONVERTED ON _____ - _____ - _____ FOR OPERATION AT <small>DAY MONTH YEAR</small> _____ ft (_____)m ALTITUDE WITH KIT NO. _____ BY _____ _____ _____</p> <p><small>(Name and address of organization making this conversion), which accepts the responsibility that this conversion has been properly made.</small></p> <p style="text-align: right;">48TM501015 REV-</p>	<p>CÉ GÉNÉRATEUR D'AIR CHAUD A ÉTÉ CONVERTI LE _____ - _____ - _____ POUR <small>JOUR MOIS ANNEE</small> UTILISATION Á UNE ALTITUDE DE _____pi (_____)m AU MOYEN DE LA TRO_USSE N°. _____ PAR _____ _____ _____</p> <p><small>(Nom et adresse de l' organisme qui a effectué la conversion), qui accepte l' entnere responsabilité de la conversion.</small></p>
-----------------------------------------------------------------------------------------------------------------------------------------------------------------------------------------------------------------------------------------------------------------------------------------------------------------------------------------------------------------------------------------------------------------------------------------------------------------------------------------------	-------------------------------------------------------------------------------------------------------------------------------------------------------------------------------------------------------------------------------------------------------------------------------------------------------------------------------------------------------------------------------------------------------------------------------------------------------------------------------

Fig. 12 — High-Altitude Responsibility Label

CONVERSION KIT RATING PLATE NATURAL GAS HIGH ALTITUDE	
REFER TO MAIN RATING PLATE FOR SPECIFIC MODEL NUMBER. THIS UNIT HAS BEEN CONVERTED TO OPERATE WITH NATURAL GAS AT ALTITUDES FROM 2,000 TO 14,000 FEET. UNITS INSTALLED AT ALTITUDES BELOW 2,000 FEET DO NOT REQUIRE CONVERSION. REFER TO KIT INSTRUCTIONS FOR CONVERSION PROCEDURES.	
CONVERSION KIT PART NUMBERS: CRLPELEV001A00, CRLPELEV002A00, CRLPELEV003A00, CRLPELEV004A00, CRLPELEV007A00, CRLPELEV008A00, CRLPELEV009A00	
MANIFOLD PRESSURE: REFER TO MAIN RATING PLATE	
GAS SUPPLY PRESSURE: REFER TO MAIN RATING PLATE	
REFER TO ALTITUDE COMPENSATION TABLES FOUND IN KIT INSTRUCTIONS FOR REQUIRED INFORMATION TO COMPLETE THIS SECTION.	
INSTALLATION ALTITUDE _____ FT	
ORIFICE SIZE INSTALLED _____	
INPUT RATE AT INSTALLATION ALTITUDE _____ BTU/HR	
FOR INSTALLATIONS IN CANADA, THE INPUT RATING SHOULD BE DERATED BY 10% FOR ALTITUDES FROM 2,000 FT (610 M) TO 4,500 FT (1372 M) ABOVE SEA LEVEL.	
PLAQUE SIGNALÉTIQUE DE TROUSSE DE CONVERSION GAZ NATUREL HAUTE ALTITUDE	
SE RÉFÉRER À LA PLAQUE SIGNALÉTIQUE PRINCIPALE POUR LE NUMÉRO DE MODÈLE SPÉCIFIQUE CET APPAREIL A FAIT L'OBJET D'UNE CONVERSION POUR UN FONCTIONNEMENT AU GAZ NATUREL À DES ALTITUDES SITUÉES ENTRE 2,000 ET 14,000 PIÈDS. LES APPAREILS INSTALLÉS EN DESSOUS DE 2,000 PIÈDS NE NéCESSITENT PAS DE CONVERSION. SE RÉFÉRER AUX INSTRUCTIONS FOURNIES AVEC LA TROUSSE POUR OBTENIR LES PROCÉDURES DE CONVERSION.	
NUMÉROS DE PIÈCE DES TROUSSES DE CONVERSION: CRLPELEV001A00, CRLPELEV002A00, CRLPELEV003A00, CRLPELEV004A00, CRLPELEV007A00, CRLPELEV008A00, CRLPELEV009A00	
PRESSION DE COLLECTEUR: SE RÉFÉRER À LA PLAQUE SIGNALÉTIQUE PRINCIPALE	
PRESSION DE L'ARRIVÉE DE GAZ: SE RÉFÉRER À LA PLAQUE SIGNALÉTIQUE PRINCIPALE	
SE RÉFÉRER AU TABLEAU DE COMPENSATION D'ALTITUDE FOURNI AVEC LA TROUSSE POUR LES INFORMATIONS NÉCESSAIRES À L'ACHÈVEMENT DE CETTE SECTION.	
ALTITUDE D'INSTALLATION _____ M	
TAILLE DE LA BUSE INSTALLÉE _____	
CAPACITÉ D'ENTRÉE À L'ALTITUDE D'INSTALLATION _____ BTU/HR	
POUR LES INSTALLATIONS AUX CANADA, LA CAPACITÉ D'ENTRÉE DOIT ÊTRE DÉPRÉCIÉE DE 10% POUR LES ALTITUDES SITUÉES ENTRE 2,000 PIÈDS (610 MÈTRES) ET 4,500 PIÈDS (1372 MÈTRES) AU DESSUS DU NIVEAU DE LA MER.	

Fig. 13 — Natural Gas Conversion Kit Rating Plate Label

Step 4 — Check Unit Operation and Make Necessary Adjustments

1. Remove manifold pressure tap plug from manifold and connect pressure gage or manometer. (See Fig. 3.)
2. Turn on electrical supply.
3. Turn on unit main gas valve.
4. Set room thermostat to call for heat. If unit has two-stage gas valve, verify high-stage heat operation before attempting to adjust manifold pressure.
5. When main burners ignite, check all fittings, manifold, and orifices for leaks.
6. Adjust pressure to value shown on the rating plate by turning the plastic adjust screw clockwise to increase pressure, counter-clockwise to decrease to pressure.
7. For two-stage gas valves, set room thermostat to call for low-stage heat. Verify, then adjust low-stage pressure to value shown on rating plate.
8. Replace regulator cover screw(s) when finished.
9. With burner access panel removed, observe unit heating operation in both high stage and low stage operation if so equipped. Observe burner flames to see if they are blue in appearance, and that the flames are approximately the same for each burner.
10. Turn off unit, remove pressure manometer and replace the 1/8-in. pipe fitting on the gas manifold. (See Fig. 3.)
11. Re-install burner access panel. (See Fig. 2.)

Table 2 — Altitude Compensation* for Low NOx Models 48FC*04-06 (L), 48GC*04-06 (L), 48JC-04-06, 48KC04-06 (L,M,N) and 48LC04-06 (L,M,N); Low NOx Models 582K04-06, 581K04-06, and 582J04-06; Low NOx Models RGV036-060, RGW036-060, and RGX036-060

NATURAL GAS ONLY										
ELEVATION		NOMINAL HEAT INPUT								
		60,000 BTUH			90,000 BTUH			120,000 BTUH		
Feet	Meters	Orifice Size	Input (btu/hr)	Kit†	Orifice Size	Input (btu/hr)	Kit†	Orifice Size	Input (btu/hr)	Kit†
0-2,000	0-610	38	60,000	2	38	90,000	2	32	120,000	1
2,000	610	39	55,200	2	39	82,800	2	33	110,400	1
3,000	914	40	52,800	**	40	79,200	**	33	105,600	1
4,000	1219	41	50,400	**	41	75,600	**	35	100,800	1
5,000	1524	41	48,000	**	41	72,000	**	35	96,000	1
6,000	1829	42	45,600	**	42	68,400	**	36	91,200	1
7,000	2134	42	43,200	**	42	64,800	**	36	86,400	1
8,000	2438	43	40,800	**	43	61,200	**	37	81,600	2
9,000	2743	43	38,400	**	43	57,600	**	38	76,800	2
10,000	3048	44	36,000	2	44	54,000	2	40	72,000	**
11,000	3353	44	33,600	2	44	50,400	2	41	67,200	**
12,000	3658	45	31,200	2	45	46,800	2	42	62,400	**
13,000	3962	47	28,800	3	47	43,200	3	43	57,600	**
14,000	4267	48	26,400	3	48	39,600	3	43	52,800	**

* As the height above sea level increases, there is less oxygen per cubic ft. of air. Therefore, heat input rate should be reduced at higher altitudes.

† See table below:

KIT	ACC. KIT PN
1	CRLPELEV001A00
2	CRLPELEV002A00
3	CRLPELEV003A00

** Not included in kit. May be purchased separately through dealer.

Table 3 — Altitude Compensation* for Carrier Models 48FC04-07 (D, E, F, S, R, T), 48GC04-06 (D, E, F, S, R, T), 48JC-04-06, 48LC04-06 (D,E,F,S,R,T); Bryant Models 582K04-07, 581K04-06; ICP Models RGV036-072; RGW036-060

NATURAL GAS — THREE PHASE																
ELEVATION		NOMINAL HEAT INPUT														
		67,000 BTUH			72,000 BTUH			110,000 BTUH			115,000 BTUH			150,000 BTUH		
Feet	Meters	Orifice Size	Input (btu/hr)	Kit†	Orifice Size	Input (btu/hr)	Kit†	Orifice Size	Input (btu/hr)	Kit†	Orifice Size	Input (btu/hr)	Kit†	Orifice Size	Input (btu/hr)	Kit†
0-2,000	0-610	37	67,000	—	33	72,000	—	33	110,000	—	33	115,000	—	30	150,000	—
2,000	610	39	62,300	2	35	67,000	1	35	102,300	1	35	107,000	1	31	139,600	1
3,000	915	40	60,100	8	36	64,600	1	36	98,700	1	36	103,200	1	31	134,600	1
4,000	1220	41	58,000	8	37	62,300	2	37	95,200	2	37	99,600	2	31	129,800	1
5,000	1525	41	55,900	8	37	60,100	2	37	91,800	2	37	96,000	2	32	125,200	1
6,000	1830	42	54,000	8	38	58,000	2	38	88,600	2	38	92,600	2	32	120,800	1
7,000	2135	42	52,100	8	39	55,900	2	39	85,500	2	39	89,300	2	33	116,500	1
8,000	2440	43	50,200	8	40	54,000	8	40	82,400	8	40	86,200	8	34	112,400	**
9,000	2745	43	48,400	8	41	52,000	8	41	79,500	8	41	83,100	8	35	108,400	1
10,000	3050	44	46,700	2	42	50,200	8	42	76,700	8	42	80,200	8	36	104,600	1
11,000	3355	44	45,100	2	42	48,400	8	42	74,000	8	42	77,300	8	36	100,900	1
12,000	3660	45	43,500	2	43	46,700	8	43	71,400	8	43	74,600	8	37	97,300	2
13,000	3965	45	41,900	2	43	45,100	8	43	68,800	8	43	72,000	8	38	93,900	2
14,000	4270	46	40,400	3	43	43,500	8	43	66,400	8	43	69,400	8	39	90,500	2

PROPANE GAS — THREE PHASE																
ELEVATION		NOMINAL HEAT INPUT														
		67,000 BTUH			72,000 BTUH			110,000 BTUH			115,000 BTUH			150,000 BTUH		
Feet	Meters	Orifice Size	Input (btu/hr)	Kit†	Orifice Size	Input (btu/hr)	Kit†	Orifice Size	Input (btu/hr)	Kit†	Orifice Size	Input (btu/hr)	Kit†	Orifice Size	Input (btu/hr)	Kit†
0-2,000	0-610	51	67,000	4	51	72,000	4	50	110,000	3	50	115,000	3	46	150,000	3
2,000	610	52	62,300	4	52	67,000	4	51	102,300	4	51	107,000	4	47	139,600	3
3,000	914	52	60,100	4	52	64,600	4	51	98,700	4	51	103,200	4	48	134,600	3
4,000	1219	52	58,000	4	52	62,300	4	52	95,200	4	52	99,600	4	48	129,800	3
5,000	1524	53	55,900	4	53	60,100	4	52	91,800	4	52	96,000	4	49	125,200	3
6,000	1829	53	54,000	4	53	58,000	4	52	88,600	4	52	92,600	4	49	120,800	3
7,000	2134	53	52,100	4	53	55,900	4	52	85,500	4	52	89,300	4	50	116,500	3
8,000	2438	53	50,200	4	53	54,000	4	53	82,400	4	53	86,200	4	50	112,400	3
9,000	2743	54	48,400	4	54	52,000	4	53	79,500	4	53	83,100	4	50	108,400	3
10,000	3048	54	46,700	4	54	50,200	4	53	76,700	4	53	80,200	4	51	104,600	4
11,000	3353	54	45,100	4	54	48,400	4	53	74,000	4	53	77,300	4	51	100,900	4
12,000	3658	54	43,500	4	54	46,700	4	54	71,400	4	54	74,600	4	52	97,300	4
13,000	3962	55	41,900	4	55	45,100	4	54	68,800	4	54	72,000	4	52	93,900	4
14,000	4267	55	40,400	4	55	43,500	4	54	66,400	4	54	69,400	4	52	90,500	4

* As the height above sea level increases, there is less oxygen per cubic ft. of air. Therefore, heat input rate should be reduced at higher altitudes.

† See table below:

KIT	ACC. KIT PN
1	CRLPELEV001A00
2	CRLPELEV002A00
3	CRLPELEV003A00
4	CRLPELEV004A00
8	CRLPELEV008A00

** Not included in kit. May be purchased separately through dealer.

Table 3 — Altitude Compensation* for Carrier Models 48FC04-07 (D, E, F, S, R, T), 48GC04-06 (D, E, F, S, R, T), 48LC04-06 (D,E,F,S,R,T); Bryant Models 582K04-07, 581K04-06; ICP Models RGV036-072; RGW036-060 (cont)

NATURAL GAS — SINGLE PHASE										
ELEVATION		NOMINAL HEAT INPUT								
		65,000 BTUH			90,000 BTUH			130,000 BTUH		
Feet	Meters	Orifice Size	Input (btu/hr)	Kit†	Orifice Size	Input (btu/hr)	Kit†	Orifice Size	Input (btu/hr)	Kit†
0-2,000	610	37	65,000	—	38	90,000	—	31	130,000	—
2,000	610	39	60,500	2	40	83,700	8	32	121,000	1
3,000	915	40	58,300	8	41	80,800	8	33	116,700	1
4,000	1220	41	56,300	8	42	77,900	8	34	112,500	**
5,000	1525	41	54,300	8	42	75,100	8	35	108,500	1
6,000	1830	42	52,400	8	43	72,500	8	36	104,700	1
7,000	2135	42	50,500	8	43	69,900	8	36	101,000	1
8,000	2440	43	48,700	8	43	67,400	8	37	97,400	2
9,000	2745	43	47,000	8	44	65,100	2	38	94,000	2
10,000	3050	44	45,300	2	44	62,700	2	39	90,600	2
11,000	3355	44	43,700	2	45	60,500	2	40	87,400	8
12,000	3660	45	42,200	2	45	58,400	2	41	84,300	8
13,000	3965	45	40,700	2	46	56,300	3	41	81,300	8
14,000	4270	46	39,200	3	47	54,300	3	42	78,500	8

PROPANE GAS — SINGLE PHASE										
ELEVATION		NOMINAL HEAT INPUT								
		65,000 BTUH			90,000 BTUH			130,000 BTUH		
Feet	Meters	Orifice Size	Input (btu/hr)	Kit†	Orifice Size	Input (btu/hr)	Kit†	Orifice Size	Input (btu/hr)	Kit†
0-2,000	610	51	65,000	4	53	90,000	4	49	130,000	3
2,000	610	52	60,500	4	53	83,700	4	50	121,000	3
3,000	915	52	58,300	4	54	80,800	4	50	116,700	3
4,000	1220	52	56,300	4	54	77,900	4	51	112,500	4
5,000	1525	53	54,300	4	54	75,100	4	51	108,500	4
6,000	1830	53	52,400	4	55	72,500	4	51	104,700	4
7,000	2135	53	50,500	4	55	69,900	4	52	101,000	4
8,000	2440	53	48,700	4	55	67,400	4	52	97,400	4
9,000	2745	54	47,000	4	55	65,100	4	52	94,000	4
10,000	3050	54	45,300	4	55	62,700	4	53	90,600	4
11,000	3355	54	43,700	4	56	60,500	4	53	87,400	4
12,000	3660	54	42,200	4	56	58,400	4	53	84,300	4
13,000	3965	55	40,700	4	56	56,300	4	53	81,300	4
14,000	4270	55	39,200	4	56	54,300	4	54	78,500	4

* As the height above sea level increases, there is less oxygen per cubic ft. of air. Therefore, heat input rate should be reduced at higher altitudes.

† See table below:

KIT	ACC. KIT PN
1	CRLPELEV001A00
2	CRLPELEV002A00
3	CRLPELEV003A00
4	CRLPELEV004A00
8	CRLPELEV008A00

** Not included in kit. May be purchased separately through dealer.

Table 4 — Altitude Compensation* for Carrier Models 48FC08-14 (D, E, F, S, R, T), 48GC07-12 (D, E, F, S, R, T), 48HC07-12 (D, E, F, S, R, T), 48LC07 (D,E,F,S,R,T), 48TC08-14 (D, E, F, S, R, T); Bryant Models 580J08-14, 581J07-12, 581K07-12 and 582K08-14; ICP Models RGS090, 091, 101, 102, 120, 121, 150; RGH072, 090, 102, 120; RGV090, 102, 120, 150; RGW072, 090, 102, 120

NATURAL GAS																			
ELEVATION		NOMINAL HEAT INPUT																	
		72,000 BTUH			125,000 BTUH			150,000 BTUH			180,000 BTUH			224,000 BTUH			250,000 BTUH		
Feet	Meters	Orifice Size	Input (btu/hr)	Kit†	Orifice Size	Input (btu/hr)	Kit†	Orifice Size	Input (btu/hr)	Kit†	Orifice Size	Input (btu/hr)	Kit†	Orifice Size	Input (btu/hr)	Kit†	Orifice Size	Input (btu/hr)	Kit†
0-2,000	0-610	33	72,000	1	31	125,000	1	32	150,000	1	31	180,000	1	31	224,000	1	30	250,000	**
2,000	610	35	66,240	1	32	115,000	1	33	138,000	1	32	165,600	1	32	206,080	1	30	230,000	**
3,000	914	35	63,360	1	32	110,000	1	35	132,000	1	32	158,400	1	32	197,120	1	31	220,000	1
4,000	1219	36	60,480	1	33	105,000	1	35	126,000	1	33	151,200	1	33	188,160	1	31	210,000	1
5,000	1524	36	57,600	1	33	100,000	1	35	120,000	1	33	144,000	1	33	179,200	1	31	200,000	1
6,000	1829	37	54,720	2	35	95,000	1	36	114,000	1	33	136,800	1	33	170,240	1	31	190,000	1
7,000	2134	38	51,840	2	35	90,000	1	36	108,000	1	35	129,600	1	35	161,280	1	32	180,000	1
8,000	2438	38	48,960	2	36	85,000	1	36	102,000	1	36	122,400	1	36	152,320	1	33	170,000	1
9,000	2743	40	46,080	**	37	80,000	2	37	96,000	2	37	115,200	2	37	143,360	2	33	160,000	1
10,000	3048	41	43,200	**	38	75,000	2	38	90,000	2	38	108,000	2	38	134,400	2	35	150,000	1
11,000	3353	42	40,320	**	39	70,000	2	40	84,000	**	39	100,800	2	39	125,440	2	36	140,000	1
12,000	3658	42	37,440	**	41	65,000	**	40	78,000	**	41	93,600	**	41	116,480	**	37	130,000	2
13,000	3962	43	34,560	**	42	60,000	**	41	72,000	**	42	86,400	**	42	107,520	**	38	120,000	2
14,000	4267	43	31,680	**	43	55,000	**	41	66,000	**	43	79,200	**	43	98,560	**	†40	110,000	**

PROPANE GAS																			
ELEVATION		NOMINAL HEAT INPUT																	
		72,000 BTUH			125,000 BTUH			150,000 BTUH			180,000 BTUH			224,000 BTUH			250,000 BTUH		
Feet	Meters	Orifice Size	Input (btu/hr)	Kit†	Orifice Size	Input (btu/hr)	Kit†	Orifice Size	Input (btu/hr)	Kit†	Orifice Size	Input (btu/hr)	Kit†	Orifice Size	Input (btu/hr)	Kit†	Orifice Size	Input (btu/hr)	Kit†
0-2,000	0-610	51	72,000	4	49	125,000	3	50	150,000	3	48	180,000	3	48	224,000	3	46	250,000	3
2,000	610	51	66,240	4	50	115,000	3	51	138,000	4	49	165,600	3	49	206,080	3	47	230,000	3
3,000	914	52	63,360	4	50	110,000	3	51	132,000	4	49	158,400	3	49	197,120	3	47	220,000	3
4,000	1219	52	60,480	4	50	105,000	3	51	126,000	4	49	151,200	3	49	188,160	3	48	210,000	3
5,000	1524	52	57,600	4	51	100,000	4	51	120,000	4	50	144,000	3	50	179,200	3	48	200,000	3
6,000	1829	52	54,720	4	51	95,000	4	52	114,000	4	50	136,800	3	50	170,240	3	48	190,000	3
7,000	2134	53	51,840	4	51	90,000	4	52	108,000	4	50	129,600	3	50	161,280	3	49	180,000	3
8,000	2438	53	48,960	4	52	85,000	4	52	102,000	4	51	122,400	4	51	152,320	4	49	170,000	3
9,000	2743	53	46,080	4	52	80,000	4	53	96,000	4	51	115,200	4	51	143,360	4	50	160,000	3
10,000	3048	54	43,200	4	52	75,000	4	53	90,000	4	52	108,000	4	52	134,400	4	50	150,000	3
11,000	3353	54	40,320	4	53	70,000	4	53	84,000	4	52	100,800	4	52	125,440	4	51	140,000	4
12,000	3658	54	37,440	4	53	65,000	4	53	78,000	4	53	93,600	4	53	116,480	4	51	130,000	4
13,000	3962	55	34,560	4	54	60,000	4	53	72,000	4	53	86,400	4	53	107,520	4	52	120,000	4
14,000	4267	55	31,680	4	54	55,000	4	55	66,000	4	54	79,200	4	54	98,560	4	53	110,000	4

* As the height above sea level increases, there is less oxygen per cubic ft. of air. Therefore, heat input rate should be reduced at higher altitudes.

† See table below:

KIT	ACC. KIT PN
1	CRLPELEV001A00
2	CRLPELEV002A00
3	CRLPELEV003A00
4	CRLPELEV004A00

** Not included in kit. May be purchased separately through dealer.

Table 5 — Altitude Compensation* for Carrier Models 48FC16 (D, E, F, S, R, T), 48GC14 (D, E, F, S, R, T), 48HC14 (D, E, F, S, R, T), 48LC08-12 (D, E, F, S, R, T), 48TC16 (D, E, F, S, R, T); Bryant Models 580J16, 581J14 and 582K16; ICP Models RGS180, RGH150 and RGV180

NATURAL GAS																
ELEVATION		NOMINAL HEAT INPUT														
		150,000 BTUH			180,000 BTUH			240,000 BTUH			315,000 BTUH			350,000 BTUH		
Feet	Meters	Orifice Size	Input (btu/hr)	Kit†	Orifice Size	Input (btu/hr)	Kit†	Orifice Size	Input (btu/hr)	Kit†	Orifice Size	Input (btu/hr)	Kit†	Orifice Size	Input (btu/hr)	Kit†
0-2,000	0-610	37	150,000	7	37	180,000	7	37	240,000	7	35	315,000	**	35	350,000	**
2,000	610	38	138,000	7	38	165,600	7	38	220,800	7	36	289,800	7	36	322,000	7
3,000	914	39	132,000	7	39	158,400	7	39	211,200	7	36	277,200	7	36	308,000	7
4,000	1219	39	126,000	7	39	151,200	7	39	201,600	7	37	264,600	7	37	294,000	7
5,000	1524	40	120,000	8	40	144,000	8	40	192,000	8	37	252,000	7	37	280,000	7
6,000	1829	41	114,000	8	41	136,800	8	41	182,400	8	38	239,400	7	38	266,000	7
7,000	2134	42	108,000	8	42	129,600	8	42	172,800	8	39	226,800	7	39	252,000	7
8,000	2438	42	102,000	8	42	122,400	8	42	163,200	8	40	214,200	8	40	238,000	8
9,000	2743	43	96,000	8	43	115,200	8	43	153,600	8	41	201,600	8	41	224,000	8
10,000	3048	43	90,000	8	43	108,000	8	43	144,000	8	42	189,000	8	42	210,000	8
11,000	3353	44	84,000	**	44	100,800	**	44	134,400	**	43	176,400	8	43	196,000	8
12,000	3658	45	78,000	**	45	93,600	**	45	124,800	**	43	163,800	8	43	182,000	8
13,000	3962	46	72,000	**	46	86,400	**	46	115,200	**	44	151,200	**	44	168,000	**
14,000	4267	47	66,000	**	47	79,200	**	47	105,600	**	45	138,600	**	45	154,000	**

PROPANE GAS																
ELEVATION		NOMINAL HEAT INPUT														
		150,000 BTUH			180,000 BTUH			240,000 BTUH			315,000 BTUH			350,000 BTUH		
Feet	Meters	Orifice Size	Input (btu/hr)	Kit†	Orifice Size	Input (btu/hr)	Kit†	Orifice Size	Input (btu/hr)	Kit†	Orifice Size	Input (btu/hr)	Kit†	Orifice Size	Input (btu/hr)	Kit†
0-2,000	0-610	52	150,000	9	52	180,000	9	52	240,000	9	51	252,000	9	51	350,000	9
2,000	610	52	138,000	9	52	165,600	9	52	220,800	9	51	231,840	9	51	322,000	9
3,000	914	53	132,000	9	53	158,400	9	53	211,200	9	52	221,760	9	52	308,000	9
4,000	1219	53	126,000	9	53	151,200	9	53	201,600	9	52	211,680	9	52	294,000	9
5,000	1524	53	120,000	9	53	144,000	9	53	192,000	9	52	201,600	9	52	280,000	9
6,000	1829	53	114,000	9	53	136,800	9	53	182,400	9	52	191,520	9	52	266,000	9
7,000	2134	53	108,000	9	53	129,600	9	53	172,800	9	53	181,440	9	53	252,000	9
8,000	2438	54	102,000	9	54	122,400	9	54	163,200	9	53	171,360	9	53	238,000	9
9,000	2743	54	96,000	9	54	115,200	9	54	153,600	9	53	161,280	9	53	224,000	9
10,000	3048	54	90,000	9	54	108,000	9	54	144,000	9	54	151,200	9	54	210,000	9
11,000	3353	55	84,000	9	55	100,800	9	55	134,400	9	54	141,120	9	54	196,000	9
12,000	3658	55	78,000	9	55	93,600	9	55	124,800	9	54	131,040	9	54	182,000	9
13,000	3962	55	72,000	9	55	86,400	9	55	115,200	9	55	120,960	9	55	168,000	9
14,000	4267	†56	66,000	**	56	79,200	**	56	105,600	**	55	110,880	9	55	154,000	9

* As the height above sea level increases, there is less oxygen per cubic ft. of air. Therefore, heat input rate should be reduced at higher altitudes.

† See table below:

KIT	ACC. KIT PN
7	CRLPELEV007A00
8	CRLPELEV008A00
9	CRLPELEV009A00

** Not included in kit. May be purchased separately through dealer.

**Table 6 — Carrier Models
Manifold Pressure Settings, LP**

CARRIER MANIFOLD PRESSURE, LP			
MODELS	SIZES	LOW FIRE	HIGH FIRE
48FCD,S	04-07	—	10.0 in. wg [2491 Pa]
48FCE,R	04-07	5.0 in. wg* (1245 Pa)	
48FCF,S	05-07	5.0 in. wg (1245 Pa)	
48FCD,S	08-09	5.0 in. wg (1245 Pa)	
48FCE,F,R,T	08-09	5.7 in. wg (1419 Pa)	
48FCD,E,F, S,R,T	12-16	5.7 in. wg (1419 Pa)	
48GCD,S	04-06	—	
48GCE,R	04-06	5.0 in. wg (1245 Pa)	10.0 in. wg (2491 Pa)
48GCF,T	05-06	5.0 in. wg (1245 Pa)	
48GCD 48GCS	07	5.0 in. wg (1245 Pa)	
	08-09	5.0 in. wg (1245 Pa)	
	11-12	5.7 in. wg (1419 Pa)	
	14	6.6 in. wg (1644 Pa)	
48GCE 48GCR	07	5.0 in. wg (1245 Pa)	10.0 in. wg (2491 Pa)
	08-09	5.7 in. wg (1419 Pa)	
	11-12	5.7 in. wg (1419 Pa)	
	14	6.6 in. wg (1644 Pa)	
48GCF 48GCT	07	5.7 in. wg (1419 Pa)	10.0 in. wg (2491 Pa)
	08-09	5.7 in. wg (1419 Pa)	
	11-12	5.7 in. wg (1419 Pa)	

**Table 6 — Carrier Models
Manifold Pressure Settings, LP (cont)**

CARRIER MANIFOLD PRESSURE, LP				
MODELS	SIZES	LOW FIRE	HIGH FIRE	
48HCD 48HCS	07	5.0 in. wg (1245 Pa)	10.0 in. wg (2491 Pa)	
	08-09	5.0 in. wg (1245 Pa)		
	11-12	5.7 in. wg (1419 Pa)		
	14	6.6 in. wg (1644 Pa)		
48HCE 48HCR	07	5.0 in. wg (1245 Pa)		
	08-09	5.7 in. wg (1419 Pa)		
	11-12	5.7 in. wg (1419 Pa)		
48HCF 48HCT	07	5.7 in. wg (1419 Pa)		
	08-09	5.7 in. wg (1419 Pa)		
	11-12	5.7 in. wg (1419 Pa)		
48JCD,S	04-06	—	10.0 in. wg	
48JCE,R	04-06	5.0 in. wg		
48JCF,S	04-06	5.0 in. wg		
48LCD,S 48LCE,R	04	5.0 in. wg (1245 Pa)	10.0 in. wg (2490 Pa)	
48LCD,S 48LCE,R 48LCF,T	05 06			
48LCD,S 48LCE,R	07			
48LCF,T	07			
48LCD,S 48LCE,R	08	5.7 in. wg (1419 Pa)		
	09			
	12			
48LCF,T	12	3.9 in. wg (971 Pa)		6.2 in. wg (1544 Pa)
48TCD 48TCS	08-09	—		10.0 in. wg (2490 Pa)
	12-14	5.7 in. wg (1419 Pa)		
	16	6.6 in. wg (1419 Pa)		
48TCE 48TCR	08-09	5.7 in. wg (1419 Pa)		
	12-14	5.7 in. wg (1419 Pa)		
	16	6.6 in. wg (1644 Pa)		
48TCF 48TCS	08-14	5.7 in. wg (1419 Pa)		
	16	6.6 in. wg (1644 Pa)		

* Size 04 only.

**Table 7 — Bryant Models
Manifold Pressure Settings, LP**

BRYANT MANIFOLD PRESSURE, LP				
MODELS	SIZES	HEATING SIZE*	LOW FIRE	HIGH FIRE
580J	08-09	125	—	10.0 in. wg (2491 Pa)
		180	5.7 in. wg (1419 Pa)	
		224		
	12-14	180	—	
		224	5.7 in. wg (1419 Pa)	
		250		
	16	180	—	
		240	6.6 in. wg (1644 Pa)	
		350		
581J	07	072	5.0 in. wg (1245 Pa)	10.0 in. wg (2491 Pa)
		115		
		150	5.7 in. wg (1419 Pa)	
	08-09	125	5.0 in. wg (1245 Pa)	
		180	5.7 in. wg (1419 Pa)	
		224		
	11-12	180	—	
		224	5.7 in. wg (1419 Pa)	
		250		
	14	180	—	
		240	6.6 in. wg (1644 Pa)	

**Table 7 — Bryant Models
Manifold Pressure Settings, LP (cont)**

BRYANT MANIFOLD PRESSURE, LP				
MODELS	SIZES	HEATING SIZE*	LOW FIRE	HIGH FIRE
581K	04	065 067	—	10.0 in. wg (2491 Pa)
		090 110	5.0 in. wg (1245 Pa)	
	05-06	065 067	—	
		090 110	5.0 in. wg (1245 Pa)	
		130 150		
	07	072	5.0 in. wg (1245 Pa)	
		115		
		150	5.7 in. wg (1419 Pa)	
	08-09	125	5.0 in. wg (1245 Pa)	
		180	5.7 in. wg (1419 Pa)	
		224		
11-12	180	—		
	224	5.7 in. wg (1419 Pa)		
	250			
14	180	—		
	240	6.6 in. wg (1644 Pa)		
582K	04	065 067	—	10.0 in. wg (2491 Pa)
		090 110	5.0 in. wg (1245 Pa)	
	05-07	065 067	—	
		090 110	5.0 in. wg (1245 Pa)	
	08-09	125	5.0 in. wg (1245 Pa)	
	08-09	180	5.7 in. wg (1419 Pa)	
		224		
	12-14	180	—	
		224	5.7 in. wg (1419 Pa)	
		250		
	16	180	—	
		240	5.7 in. wg (1419 Pa)	
		350		

* Heating Size is positions 9, 10 and 11 of the model number

**Table 8 — ICP Models
Manifold Pressure Settings, LP**

ICP MANIFOLD PRESSURE, LP				
MODELS	SIZES	HEATING SIZE*	LOW FIRE	HIGH FIRE
RGH	072	D,S	5.0 in. wg (1245 Pa)	10.0 in. wg (2491 Pa)
		E,R		
		F,T	5.7 in. wg (1419 Pa)	
	090-102	D,S	5.0 in. wg (1245 Pa)	
		E,R	5.7 in. wg (1419 Pa)	
		F,T		
	120	D,S	5.7 in. wg (1419 Pa)	
		E,R		
		F,T		
	150	D,S	6.6 in. wg (1644 Pa)	
		E,R		
		F		
RGS	089-102	D,S	—	
		E,R	5.7 in. wg (1419 Pa)	
		F,T		
	120-150	D,S	5.7 in. wg (1419 Pa)	
		E,R		
		F,T		
	180	D,S	6.6 in. wg (1644 Pa)	
		E,R		
		F,T		

**Table 8 — ICP Models
Manifold Pressure Settings, LP (cont)**

ICP MANIFOLD PRESSURE, LP					
MODELS	SIZES	HEATING SIZE*	LOW FIRE	HIGH FIRE	
RGV	036	D,S	—	10.0 in. wg (2491 Pa)	
		E,R	5.0 in. wg (1245 Pa)		
	048-072	D,S	—		
		E,R	5.0 in. wg (1245 Pa)		
		F,T			
	090-102	D,S	5.0 in. wg (1245 Pa)		
	090-102	E,F,R,T	5.7 in. wg (1419 Pa)		
	120-180	D,E,F,S,R,T	5.7 in. wg (1419 Pa)		
	RGW	036	D,S		—
			E,R		5.0 in. wg (1245 Pa)
048-060		D,S	—		
		E,R	5.0 in. wg (1245 Pa)		
		F,T			
072		D,S	5.0 in. wg (1245 Pa)		
		E,R	5.7 in. wg (1419 Pa)		
F,T					
090-102		D,S	5.0 in. wg (1245 Pa)		
		E,R	5.7 in. wg (1419 Pa)		
		F,T			
120		D,S	5.7 in. wg (1419 Pa)		
		E,R			
		F,T			
150		D,S	6.6 in. wg (1644 Pa)		
		E,R			
		F			
RGX		036-060	D,E,F,S,R,T	—	10.0 in. wg (2491 Pa)

* Heating Size is Positions 8 of the Model Number.